



F-ZERO AX™

(DX TYPE)

OWNER'S MANUAL



- Before using this product, read this MANUAL carefully to understand the contents herein stated.
- After reading this manual, be sure to keep it available nearby the product or elsewhere convenient for referring to it anytime when necessary.

SEGA CORPORATION

F-ZERO AX (DX TYPE) OWNER'S MANUAL

MANUAL NO. 420-6769-01



SEGA CORPORATION

12-14, Higashikohjiya 2-Chome, Ohta-ku, Tokyo 144-8532, Japan
Phone: +81-3-5737-7544 Facsimile: +81-3-5737-7746

© 2003 Nintendo
© AMUSEMENT VISION/SEGA, 2003
TRIFORCE is a trademark of NINTENDO.
F-ZERO is a trademark of Nintendo.

MANUAL NO. 420-6769-01

BEFORE USING THE PRODUCT, BE SURE TO READ THE FOLLOWING:

To maintain the safety:

To ensure the safe usage of the product, be sure to read the following before using the product. The following instructions are intended for the users, operators and the personnel in charge of the operation of the product. After carefully reading and sufficiently understanding the warning displays and cautions, handle the product appropriately. Be sure to keep this manual nearby the product or elsewhere convenient for referring to it when necessary.

Herein, explanations which require special attention are enclosed with dual lines. Depending on the potentially hazardous degrees, the terms of DANGER, WARNING, CAUTION, etc. are used. Be sure to understand the contents of the displays before reading the text.



Indicates that mishandling the product by disregarding this pictograph will cause severe injury or death.



Indicates that mishandling the product by disregarding this caution will cause a slight hazardous situation which can result in personal injury and/or material damage.



Indicates that mishandling the product by disregarding this warning will cause a potentially hazardous situation which can result in death or serious injury.

For the safe usage of the product, the following pictographs are used:



Indicates "HANDLE WITH CARE." In order to protect the human body and equipment, this display is attached to places where the Owner's/Service Manual and/or Service Manual should be referred to.



Indicates a "Protective Earth Terminal." Before operating the equipment, be sure to connect it to the Ground.
(Except the product with which the power cord with earth is used.)

- **Perform work in accordance with the instructions herein stated.**
Instructions for work are explained by paying attention to the aspect of accident prevention. Failing to perform work as per the instructions can cause accidents. In the case where only those who have technical expertise should perform the work to avoid hazardous situation, the instructions herein state that the serviceman should perform such work.
- **Be sure to turn off power before working on the machine.**
To prevent electric shock, be sure to turn off power before starting the work in which the worker touches the interior of the product. If the work is to be performed in the power-on status, the Instruction Manual herein always states to that effect.
- **Be sure to ground the Earth Terminal.**
(This is not required in the case where a power cord with earth is used.)
This product is equipped with the Earth Terminal. When installing the product, Connect the Earth Terminal to the "accurately grounded indoor earth terminal" by using an earth wire. Unless the product is grounded appropriately, the user can be subject to electric shock. After performing repair, etc. for the Control equipment, ensure that the Earth Wire is firmly connected to the Control equipment.
- **Ensure that the Power Supply used is equipped with an Earth Leakage Breaker.**
This product does not incorporate the Earth Leakage Breaker. Using a power supply which is not equipped with the Earth Leakage Breaker can cause a fire when earth leakage occurs.
- **Be sure to use fuses which meet the specified rating.**
(Only for the machines which use fuses.)
Using fuses exceeding the specified rating can cause a fire and electric shock.

- **Specification changes (removal of equipment, conversion and addition) not designated by SEGA are not allowed.**

The parts of the product include warning labels for safety, covers for personal protection, etc. It is very hazardous to operate the product by removing parts and or modifying the circuits. Should doors, lids and protective parts be damaged or lost, refrain from operating the product, and contact where the product was purchased from or the office herein stated.

SEGA shall not be held responsible for any accidents, compensation for damage to a third party, resulting from the specifications not designated by SEGA.

- **Ensure that the product meets the requirements of appropriate Electrical Specifications.**

Before installing the product, check for Electrical Specifications. SEGA products have a nameplate on which Electrical Specifications are described. Ensure that the product is compatible with the power supply voltage and frequency requirements of the location. Using any Electrical Specifications different from the designated Specifications can cause a fire and electric shock.

- **Install and operate the product in places where appropriate lighting is available, allowing warning labels to be clearly read.**

To ensure safety for the customers, labels and printed instructions describing potentially hazardous situation are applied to places where accidents can be caused. Ensure that where the product is operated has sufficient lighting allowing the warnings to be read. If any label is peeled off, apply it again immediately. Please place an order with where the product was purchased from or the office herein stated.

- **When handling the Monitor, be very careful. (Applies only to the product with monitor.)**

Some of the monitor (TV) parts are subject to high tension voltage. Even after turning off power, some portions are still subject to high tension voltage sometimes. Monitor repair and replacement should be performed only by those technical personnel who have knowledge of electricity and technical expertise.

- **Be sure to adjust the monitor (projector) properly. (Applies only to the product with monitor.)**

Do not operate the product leaving on-screen flickering or blurring as it is. Using the product with the monitor not properly adjusted may cause dizziness or a headache to an operator, a player, or the customers.

- **When transporting or reselling this product, be sure to attach this manual to the product.**

In the case where commercially available monitors and printers are used in this product, only the contents relating to this product are explained herein. Some commercially available equipment has functions and reactions not stated in this manual. Read this manual together with the specific Instruction Manual of such equipment.

* Descriptions herein contained may be subject to improvement changes without notice.

* The contents described herein are fully prepared with due care. However, should any question arise or errors be found, please contact SEGA.

INSPECTIONS IMMEDIATELY AFTER TRANSPORTING THE PRODUCT TO THE LOCATION

Normally, at the time of shipment, SEGA products are in a status allowing for usage immediately after transporting to the location. Nevertheless, an irregular situation may occur during transportation. Before turning on power, check the following points to ensure that the product has been transported in a satisfactory status.

- Are there any dented portions or defects (cuts, etc.) on the external surfaces of the cabinet?
- Are Casters and Adjusters, damaged?
- Do the power supply voltage and frequency requirements meet with those of the location?
- Are all wiring connectors correctly and securely connected? Unless connected in the correct direction, connector connections can not be made accurately. Do not insert connectors forcibly.
- Do power cords have cuts and dents?
- Do the fuses used meet specified rating? Is the Circuit Protector in an energized status?
- Are all accessories available?
- Can all Doors and Lids be opened with the Accessory keys? Can Doors and Lids be firmly closed?

CONCERNING THE STICKER DISPLAY

SEGA product has Stickers describing the product manufacture No. (Serial No.) and Electrical Specifications. Also it has a Sticker describing where to contact for repair and for purchasing parts. When inquiring about or asking for repair, mention the Serial No. and Name of Machine indicated on the Sticker. The Serial No. indicates the product register. Identical machines could have different parts depending on the date of production. Also, improvements and modifications might have been made after the publication of this Manual. In order to meet the above situations, mention the Serial No. when contacting the applicable places.

CONCERNING WARNING DISPLAYS

SEGA product has warning displays on Stickers, Labels and or printed instructions adhered/attached to or incorporated in the places where a potentially hazardous situation can arise. The warning displays are intended for accident prevention for the customers and for avoiding hazardous situation relating to maintenance and servicing work. There are some portions in the Cabinet, which are subject to high tension voltage, etc. where accidents can be caused merely by touching. When performing the servicing work, be very careful of the warning displays. Especially, any complex repair and replacement work not mentioned herein, should be performed by those technical personnel who have knowledge of electricity and technical expertise. For the prevention of accidents, caution any customer whose act runs counter to the warnings, as to the effect that he must stop the act.

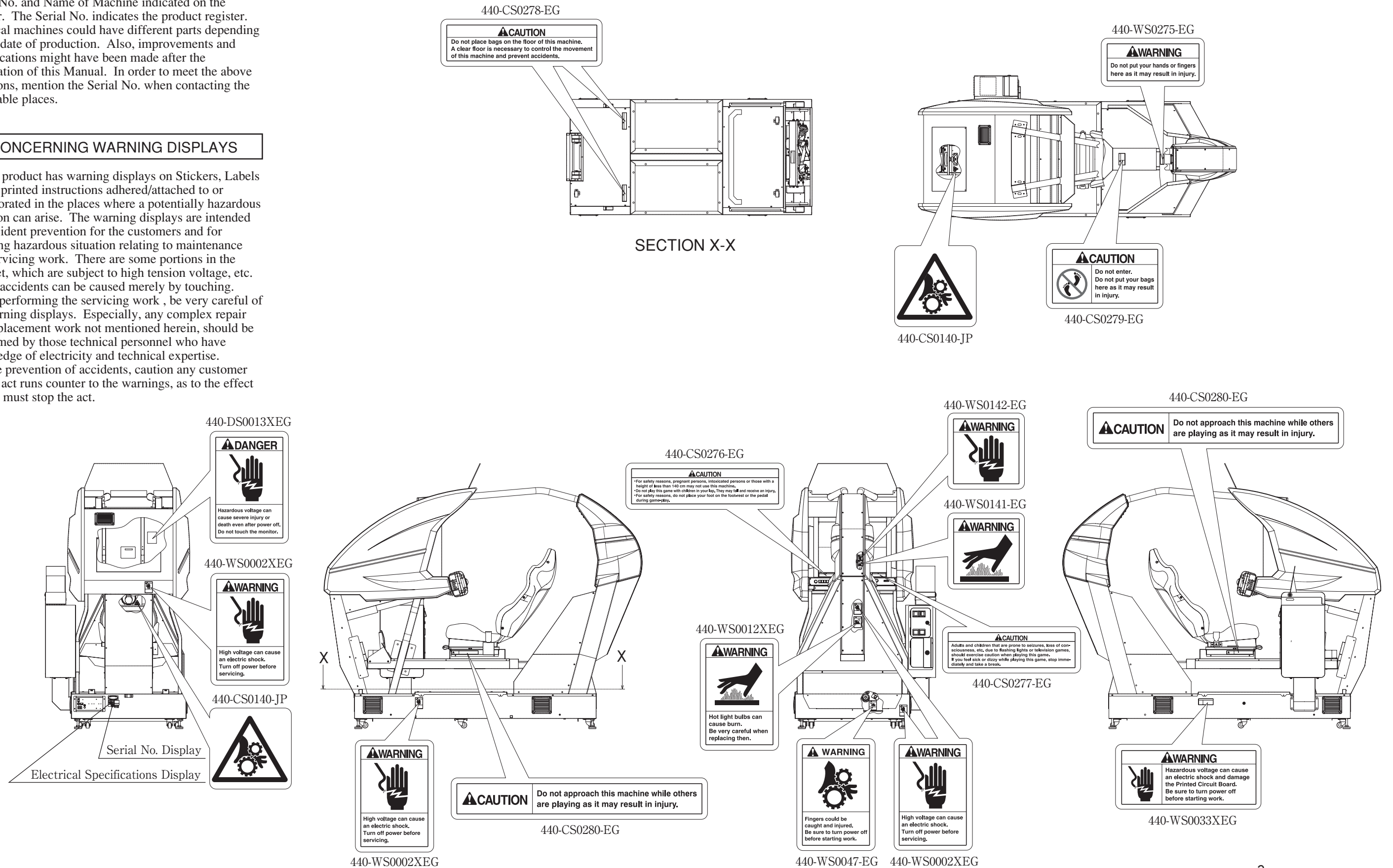

TABLE OF CONTENTS

BEFORE USING THE PRODUCT, BE SURE TO READ THE FOLLOWING:

TABLE OF CONTENTS

INTRODUCTION

1. HANDLING PRECAUTIONS	1
2. PRECAUTIONS REGARDING INSTALLATION LOCATION	5
3. PRECAUTIONS REGARDING PRODUCT OPERATION	8
4. NAMES OF PARTS	17
5. ACCESSORIES	18
6. ASSEMBLY AND INSTALLATION	22
7. CARD READER/WRITER.....	40
7-1 SETTING DEDICATED CARDS.....	40
7-2 HEAD CLEANING	42
7-3 CLEARING CARD JAMS	43
8. PRECAUTIONS WHEN MOVING THE MACHINE.....	45
8-1 MOVING THE MACHINE	45
8-2 DISASSEMBLING AND MOVING THE MACHINE	48
9. GAME DESCRIPTION.....	60
10. TEST AND DATA DISPLAY	71
10-1 SWITCH UNIT AND COIN METER	72
10-2 SYSTEM TEST MODE	74
10-3 GAME TEST MODE.....	89
11. STEERING UNIT	109
11-1 ADJUSTING AND REPLACING THE Y-AXIS VR	110
11-2 REPLACING THE MICROSWITCHES	116
11-3 GREASING	119
12. MAINTAINING THE BASE INTERIOR	120
12-1 ADJUSTING AND REPLACING THE STEERING VR.....	121
12-2 ADJUSTING AND REPLACING THE ROLL VR	125
12-3 GREASING	128
12-4 MAINTAINING THE SEAT MOTION MECHANISM.....	129
13. ACCELERATOR & BRAKE	131
13-1 ADJUSTING OR REPLACING THE VOLUME	131
13-2 GREASING	132
14. COIN SELECTOR	133
15. MONITOR.....	134
15-1 CAUTIONS AND WARNINGS CONCERNING THE SAFETY FOR HANDLING THE MONITORS.....	135
15-2 CLEANING THE CRT SURFACES.....	135
15-3 ADJUSTMENT PROCEDURE	136
16. REPLACING THE FLUORESCENT LAMPS.....	139
17. PERIODIC INSPECTION TABLE	141
18. TROUBLESHOOTING	143
18-1 CARD READER/WRITER.....	143
18-2 GAME BOARD-RELATED ERROR MESSAGES	145
18-3 DRIVE BOARD 7-SEG MESSAGES	150
18-4 OTHER MECHANICAL ERROR MESSAGES (EXCL. CARD READER/WRITER)	152
18-5 PROBLEMS NOT COVERED BY ERROR MESSAGES	153
19. GAME BOARD	159
19-1 REMOVING THE GD-ROM DRIVE	160
19-2 REMOVING THE GAME BOARD (TRIFORCE)	162
19-3 COMPOSITION OF THE GAME BOARD	163
19-4 REPLACING THE MAIN BOARD BATTERY	164
19-5 REPLACING THE DIMM BOARD BATTERY PACK	165
19-6 SHIPPING THE GAME BOARD AND GD-ROM DRIVE	169
20. DESIGN RELATED PARTS	171
21. NETWORK PLAY	174
21-1 PRECAUTIONS REGARDING NETWORK PLAY SETUP.....	174
21-2 CONNECTING NETWORK CABLES	176
21-3 NETWORK PLAY SETTINGS	179
21-4 GENERAL PRECAUTIONS REGARDING NETWORK PLAY.....	180

22. PARTS LIST	181
23. WIRE COLOR CODE TABLE	242
24. WIRING DIAGRAM	243

SPECIFICATIONS

Installation space	: 1,200 mm (W) × 2,640 mm (D) (47.2 in. × 103.9 in.)
Height	: 2,200 mm (86.6 in.)
Weight	: 527 kg (1,161.8 lbs.)
Power, maximum current	: 371 W 4.02 A (AC 120 V 60 Hz AREA) 375 W 2.22 A (AC 220 V 50 Hz AREA) 383 W 2.24 A (AC 220 V 60 Hz AREA) 391 W 2.2 A (AC 230 V 50 Hz AREA) 400 W 2.16 A (AC 240 V 50 Hz AREA)
For TAIWAN	
Power, current	: 455 W 4.8 A (MAX.) 250 W 2.6 A (MIN.)
MONITOR	: 29 TYPE COLOR MONITOR

INTRODUCTION

This manual is intended to provide detailed descriptions together with all the necessary information covering the general operation of electronic assemblies, electromechanicals, servicing control, spare parts, etc. as regards the product, **"F-ZERO AX (DX TYPE)**.

This manual is intended for the owners, personnel and managers in charge of operation of the product. Operate the product after carefully reading and sufficiently understanding the instructions. If the product fails to function satisfactorily, non-technical personnel should under no circumstances touch the internal system. Should any malfunctioning occur, turn the power off and unplug the AC Cable (Power Cord), and contact where the product was purchased from.

Use of this product is unlikely to cause physical injuries or damages to property. However, points that require special attention are indicated by thick underlining, the word "IMPORTANT" and the symbol below.



Indicates that mishandling the product by disregarding this display can cause the product's intrinsic performance not to be obtained, resulting in malfunctioning.

IMPORTANT

SEGA ENTERPRISES, INC. (U.S.A.)/CUSTOMER SERVICE
45133 Industrial Drive, Fremont, California 94538, U.S.A.
Phone: (415) 701-6580
Facsimile: (415) 701-6594

Definition of 'Site Maintenance Personnel or Other Qualified Individuals'



Procedures not described in this manual or marked as 'to be carried out by site maintenance personnel or other qualified professionals' should not be carried out by personnel without the necessary skill or technology. Work carried out by unqualified persons may cause serious accidents, including electrocution.

Parts replacement, maintenance inspections and troubleshooting should be carried out by site maintenance personnel or other qualified professionals. This manual includes directions that potentially dangerous procedures should only be carried out by professionals with the appropriate specialized knowledge.

The 'site maintenance personnel or other qualified professionals' mentioned in this manual are defined as follows:

Site maintenance personnel:

Persons with experience in maintaining amusement equipment, vending machines, etc., working under the supervision of the owner/operator of this product to maintain machines within amusement facilities or similar premises by carrying out everyday procedures such as assembly, maintenance inspections, and replacement of units/expendable parts.

Activities to be carried out by site maintenance personnel:

Amusement equipment/vending machine assembly, maintenance inspection and replacement of units/expendable parts.

Other qualified professionals:

Persons employed by amusement equipment manufacturers, involved in design, production, testing or maintenance of amusement equipment. Should have graduated from technical school or hold similar qualifications in electrician/electronics/mechanical engineering.

Activities to be carried out by other qualified professionals:

Amusement equipment/vending machine assembly, repair/adjustment of electrical/electronic/mechanical parts.

1. HANDLING PRECAUTIONS

When installing or inspecting the machine, be very careful of the following points and pay attention to ensure that the player can enjoy the game safely.

Non-compliance with the following points or inappropriate handling running counter to the cautionary matters herein stated can cause personal injury or damage to the machine.



- Before performing work, be sure to turn power off. Performing the work without turning power off can cause an electric shock or short circuit. In the case work should be performed in the status of power on, this manual always states to that effect.
- To avoid electric shock or short circuit, do not plug in or unplug quickly.
- To avoid electric shock, do not plug in or unplug with a wet hand.
- Do not expose Power Cords and Earth Wires on the surface, (floor, passage, etc.). If exposed, the Power Cords and Earth Wires are susceptible to damage. Damaged cords and wires can cause electric shock or short circuit.
- To avoid causing a fire or electric shock, do not put things on or damage Power Cords.
- When or after installing the product, do not unnecessarily pull the power cord. If damaged, the power cord can cause a fire or electric shock.
- In case the power cord is damaged, ask for replacement through where the product was purchased from or the office herein stated. Using the cord as is damaged can cause fire, electric shock or leakage.
- Be sure to perform grounding appropriately. Inappropriate grounding can cause an electric shock.
- Be sure to use fuses meeting specified rating. Using fuses exceeding the specified rating can cause a fire or electric shock.
- Completely make connector connections for IC BD and others. Insufficient insertion can cause an electric shock.
- Specification changes, removal of equipment, conversion and/or addition, not designated by SEGA are not permitted.
 - Failure to observe this may cause a fire or an electric shock. Non-compliance with this instruction can have a bad influence upon physical conditions of the players or the lookers-on, or result in injury during play.
 - SEGA shall not be held responsible for damage, compensation for damage to a third party, caused by specification changes not designated by SEGA.
- Be sure to perform periodic maintenance inspections herein stated.



- For the IC board circuit inspections, only the logic tester is allowed. The use of a multiple-purpose tester is not permitted, so be careful in this regard.
- The Projector is employed for this machine. The Projector's screen is susceptible to damage, therefore, be very careful when cleaning the screen. For details, refer to PROJECTOR.
- Static electricity from your body may damage some electronics devices on the IC board. Before handling the IC board, touch a grounded metallic surface so that the static electricity can be discharged.
- Some parts are the ones designed and manufactured not specifically for this game machine. The manufacturers may discontinue, or change the specifications of, such general-purpose parts. If this is the case, Sega cannot repair or replace a failed game machine whether or not a warranty period has expired.

2. PRECAUTIONS REGARDING INSTALLATION LOCATION



This product is an indoor game machine. Do not install it outside. Even indoors, avoid installing in places mentioned below so as not to cause a fire, electric shock, injury and or malfunctioning.

- Places subject to rain or water leakage, or places subject to high humidity in the proximity of an indoor swimming pool and or shower, etc.
- Places subject to direct sunlight, or places subject to high temperatures in the proximity of heating units, etc.
- Places filled with inflammable gas or vicinity of highly inflammable/ volatile chemicals or hazardous matter.
- Dusty places.
- Sloped surfaces.
- Places subject to any type of violent impact.
- Vicinity of anti-disaster facilities such as fire exits and fire extinguishers.
- The operating (ambient) temperature range is from 5°C to 30°C.

LIMITATIONS OF USAGE REQUIREMENTS



- Be sure to check the Electrical Specifications. Ensure that this product is compatible with the location's power supply, voltage and frequency requirements. A plate describing Electrical Specifications is attached to the product. Non-compliance with the Electrical Specifications can cause a fire and electric shock.
- This product requires the Breaker and Earth Mechanisms as part of the location facilities. Using them in a manner not independent can cause a fire and electric shock.
- Ensure that the indoor wiring for the power supply is rated at 7 A or higher (AC single phase 100 ~ 120 V area), and 4 A or higher (AC 220 ~ 240 V area). Non-compliance with the Electrical Specifications can cause a fire and electric shock.
- Be sure to independently use the power supply equipped with the Earth Leakage Breaker. Using a power supply without the Earth Leakage Breaker can cause an outbreak of fire when earth leakage occurs.
- Putting many loads on one electrical outlet can cause generation of heat and a fire resulting from overload.
- When using an extension cord, ensure that the cord is rated at 7 A or higher (AC 100 ~ 120 V area) and 4 A or higher (AC 220 ~ 240 V area). Using a cord rated lower than the specified rating can cause a fire and electric shock.

OPERATION AREA



WARNING

- For the operation of this machine, secure a minimum area of 2.35 m (W) × 3.5 m (D). In order to prevent injury resulting from the falling down accident during game play, be sure to secure the minimum area for operation.
- Be sure to provide sufficient space so as to allow this product's ventilation fan to function efficiently. To avoid machine malfunctioning and a fire, do not place any obstacles near the ventilation opening.
- SEGA shall not be held responsible for damage, compensation for damage to a third party, resulting from the failure to observe this instruction.
- If the machine does not fit through the entryway to the installation location, do not disassemble it without first consulting the instructions. The machine should only be disassembled in accordance with the instructions listed in this manual; do not attempt to disassemble it in any other way. Specific tools and adjustment procedures are required to assemble and disassemble the mechanical parts. Attempting to assemble or disassemble the machine without consulting the instructions may result in accidents during assembly/disassembly and electric shock, short circuits, and/or personal injury during operation. If the machine still does not fit through the entryway after following the procedures in this manual, contact your retailer or the office listed in this manual.
- If the machine is still too large to fit through the entryway after following the procedures listed in this manual, do not tip the machine on its side. Attempting to transport the machine while it is tipped on its side may cause accidents. It may also damage or warp parts of the machine, resulting in accidents during operation.



IMPORTANT

For transporting the machine into the location's building, the minimum necessary dimensions of the opening (of doors, etc.) are 1.3 m (W) and 2.1 m (H).

Electric current consumption

MAX. 4.02 A (AC 120 V 60 Hz)
MAX. 2.22 A (AC 220 V 50 Hz)
MAX. 2.24 A (AC 220 V 60 Hz)
MAX. 2.2 A (AC 230 V 50 Hz)
MAX. 2.16 A (AC 240 V 50 Hz)
MAX. 4.8 A (For TAIWAN)

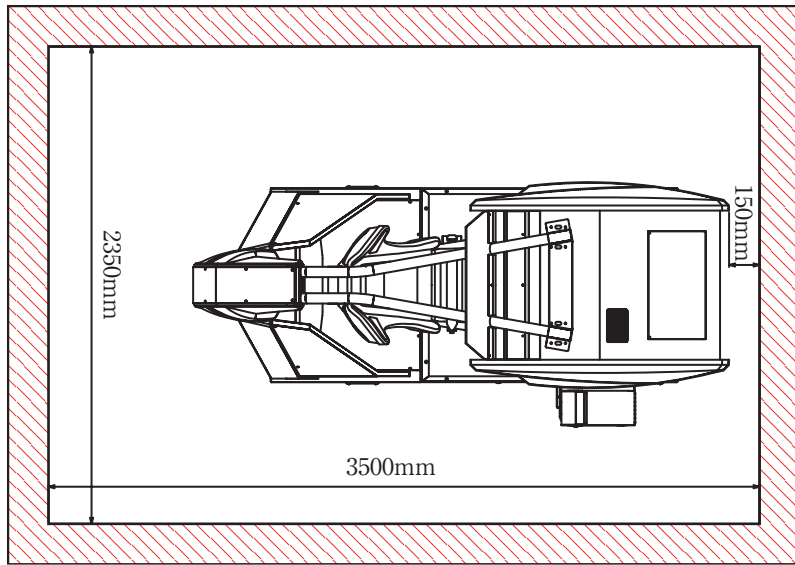

FIG. 2 a

If the entryway to the installation location is too narrow or too low, follow the steps listed in this manual to disassemble the machine. (See Section 8-2.)

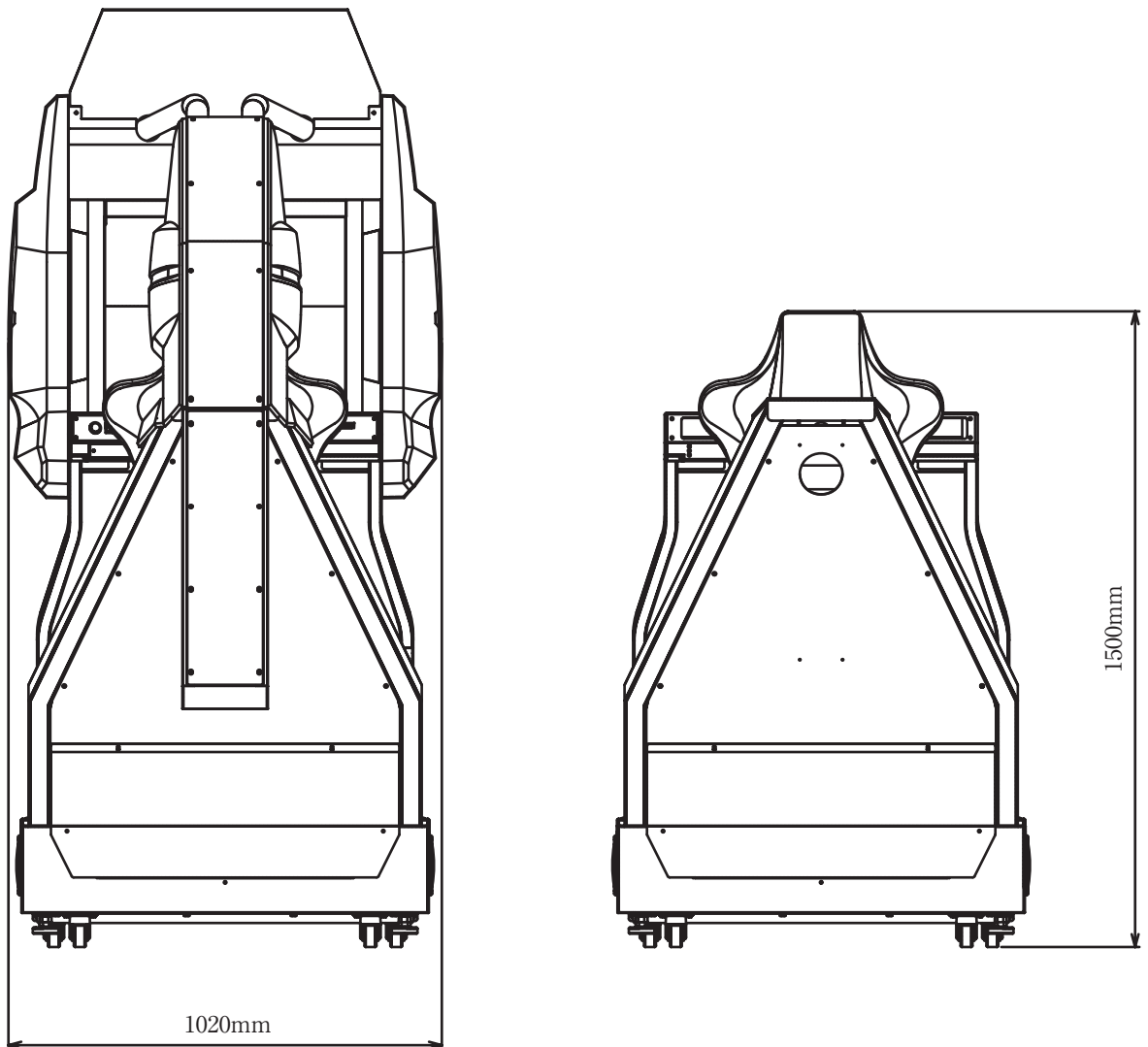

FIG. 2 b DIMENSIONS OF THE MACHINE DISASSEMBLED

3. PRECAUTIONS REGARDING PRODUCT OPERATION

BEFORE OPERATING

To avoid injury and trouble, be sure to constantly give careful attention to the behavior and manner of the visitors and players.



In order to avoid accidents, check the following before starting the operation:

- To ensure maximum safety for the players and the customers, ensure that where the product is operated has sufficient lighting to allow any warnings to be read. Operation under insufficient lighting can cause bodily contact with each other, hitting accident, and or trouble between customers.
- Be sure to perform appropriate adjustment of the monitor (projector). For operation of this machine, do not leave monitor's flickering or deviation as is. Failure to observe this can have a bad influence upon the players' or the customers' physical conditions.
- It is suggested to ensure a space allowing the players who feel sick while playing the game to take a rest.
- Check if all of the adjusters are in contact with the surface. If they are not, the Cabinet can move and cause an accident.

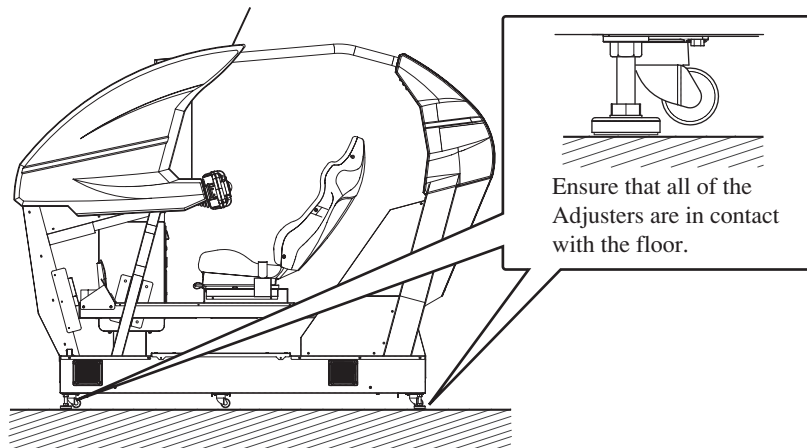

- Do not put any heavy item on this product. Placing any heavy item on the product can cause a falling down accident or parts damage.
- Do not climb on the product. Climbing on the product can cause falling down accidents. To check the top portion of the product, use a step.
- To avoid electric shock, check to see if door & cover parts are damaged or omitted.
- To avoid electric shock, short circuit and or parts damage, do not put the following items on or in the periphery of the product. Flower vases, flowerpots, cups, water tanks, cosmetics, and receptacles/containers/vessels containing chemicals and water.



- Make sure the surrounding area is secure before turning the power on. The machine will automatically go through an initialization process after being turned on. The seat will move left and right, and persons standing in the vicinity of the machine may be struck or knocked down.
- Be sure to perform a test run of the machine and inspect its safety devices before putting it into operation. Because the machine's seat swerves to the left and right, it is equipped with safety devices. In order to ensure that these safety devices are functioning properly, it is imperative that the following checks be performed on a regular basis:
 - When the safety belt is released, does the seat stop moving?
 - Does the safety belt hold the player's body firmly in place?
 - Are there any damaged or frayed spots on the safety belt?
 - Are any of the seat parts loose or wobbly?
 - When the "Motion Stop" button is pressed, does the seat stop moving?
 - When the safety sensor detects a foreign object, does the seat stop moving?
 - Are the yellow-and-black-striped parts on the front and rear of the cockpit frame torn or missing?
- When performing the above safety checks, verify also that the seat is moving properly. Accidents may occur if the seat is moving abnormally. For this reason, do not operate the machine in such cases until the problem is resolved.
 - Does the seat move in the direction that the controls are pressed?
 - Does the seat move smoothly?
 - Does the seat shake or rattle?
 - Are any unusual sounds produced during seat motion?
 - Does the seat experience unusual vibration while moving?
 - When the game is over, does the seat come to rest in a level position?
- If the yellow-and-black-striped parts at the front and rear of the cockpit become damaged or fall off, replace them immediately. Hands and fingers may be broken and/or severed if inserted into these areas during gameplay.
- If the seat motion mechanism begins to malfunction, immediately cease operation, turn off the power, unplug the power cord, and contact the office listed in this manual or your retailer. Continuing to operate the machine without resolving the problem may result in serious accidents such as electric shock, short circuits, or fire, and/or cause the machine to tip over.
- Requests for maintenance of the seat motion mechanism should be directed to the office listed in this manual or your retailer. Attempts to perform maintenance by persons other than specially trained technicians may result in injury to the party performing the maintenance and/or to players during product operation.
- The seat will continue to move even if it comes into contact with persons other than the player. In order to ensure a safe operating environment, place the machine so that one side is adjacent to the back of another game machine or to the wall.



- To avoid injury, be sure to provide sufficient space by considering the potentially crowded situation at the installation location. Insufficient installation space can cause making bodily contact with each other, hitting accidents, and or trouble between customers.
- Check the control devices to make sure that there are no scratches or cracks on parts touched by players, as such defects can cause injury to hands and fingers.



This product features a license card slot and a memory card slot. Check to make sure that these parts have not been tampered with (e.g. by inserting foreign objects.)

DURING OPERATION (PATRON CONDUCT)

To avoid injury and trouble, be sure to constantly give careful attention to the behavior and manner of the visitors and players.



- To avoid injury and accidents, those who fall under the following categories are not allowed to play the game.
 - Those who need assistance such as the use of an apparatus when walking.
 - Those who have high blood pressure or a heart problem.
 - Those who have experienced muscle convulsion or loss of consciousness when playing video game, etc.
 - Those who have a trouble in the neck and or spinal cord.
 - Intoxicated persons.
 - Pregnant women or those who are in the likelihood of pregnancy.
 - Persons susceptible to motion sickness.
 - Persons whose act runs counter to the product's warning displays.
- A player who has never been adversely affected by light stimulus might experience dizziness or headache depending on his physical condition when playing the game.
- Instruct those who feel sick during play to have a medical examination.
- To avoid injury resulting from falling down and electric shock due to spilled drinks, instruct the player not to place heavy items or drinks on the product.
- To avoid electric shock and short circuit, do not allow patrons to put hands and fingers or extraneous matter in the openings of the product or small openings in or around the doors.
- To avoid falling down and injury resulting from falling down, immediately stop patron's leaning against or climbing on the product, etc.
- To avoid electric shock and short circuit, do not allow patrons to unplug the power plug without a justifiable reason.
- For safety reasons, this game must not be played by persons less than 140 cm in height. Patrons should be told that this is because the safety belt cannot secure such persons in place.

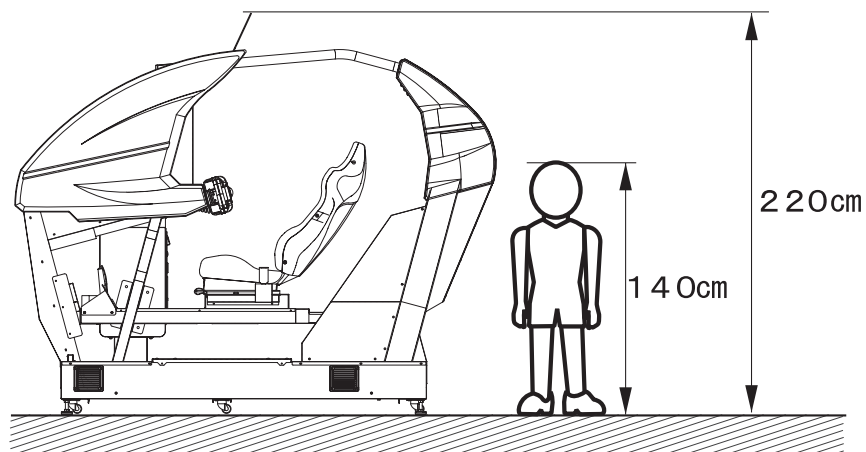



- Playing the game without first securing the safety belt may cause players to fall out. Patrons should be instructed always to secure themselves with the safety belt before playing the game.

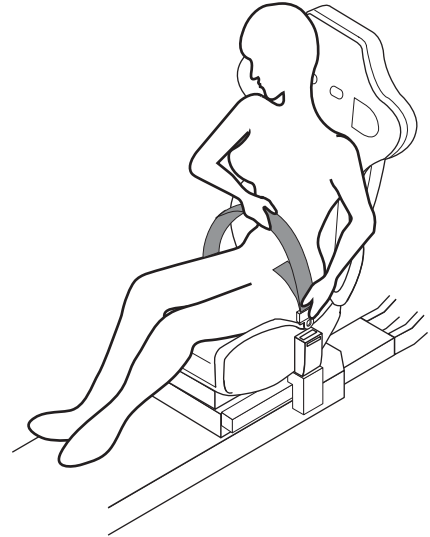

- Prevent patrons from sitting two at a time in the seat. This game is for one player only. If two or more patrons attempt to sit in the seat and play at the same time, they may hit their heads, hands, or elbows, possibly resulting in serious injury.



- Patrons should not be allowed to climb onto the back of the seat. Such behavior may cause players to fall out and/or cause the machine to tip over. If a patron is riding on the back of the seat, have him or her get off immediately.

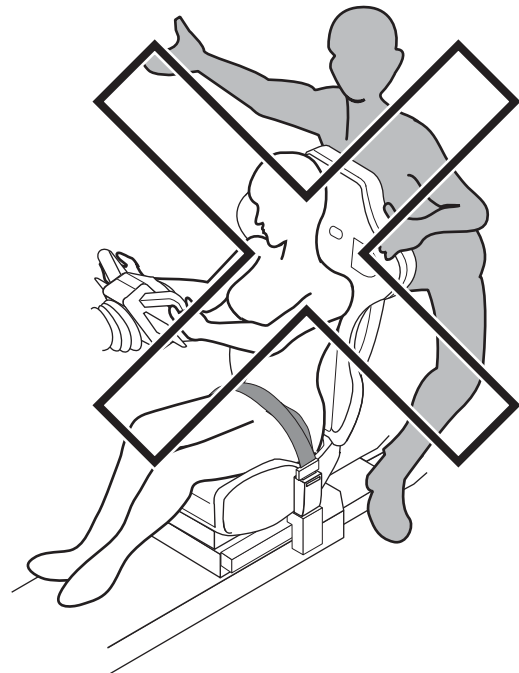



- Patrons should be warned not to place children on their laps while they play the game. Doing so may cause the child to become trapped between the player and the control panel and/or cause the machine to tip over.

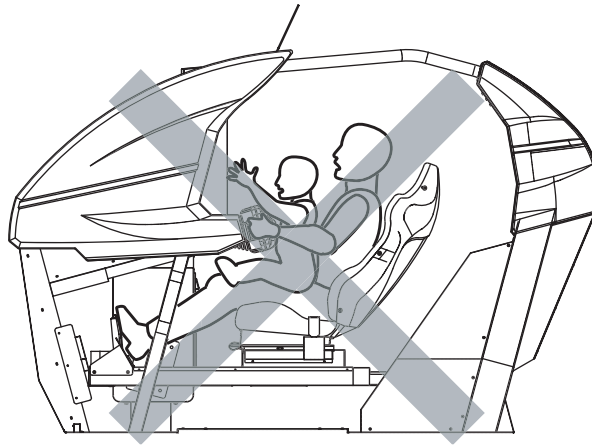

- Persons other than the player should not be allowed to approach the machine while the seat is in motion. Such actions may result in sideswiping and/or collision accidents. The safety sensor is only able to detect foreign objects on top of the base. Young children are especially susceptible to this danger; for this reason, patrons should be instructed to watch their children closely.

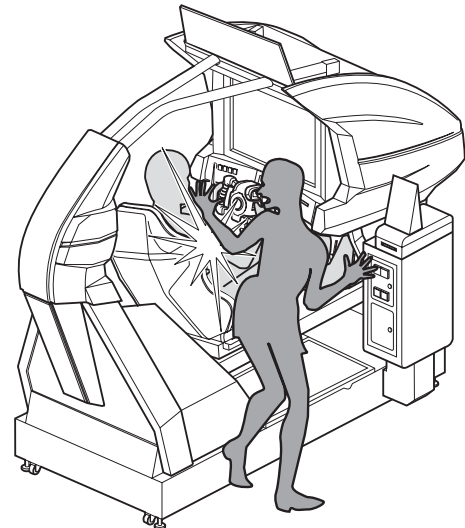

- Patrons should be advised to place their feet upon the pedals during play. If patrons move their legs around without due attention, they may become trapped or snagged, possibly resulting in broken bones and/or sprains.
- Prevent patrons from playing the game with bag straps or scarves wrapped around their necks or while holding on to drinks, as this can lead to accidents.
- If a player appears to be in distress, stop the seat motion immediately by pressing the "Motion Stop" button.



- Immediately stop such violent acts as hitting and kicking the product. Such violent acts can cause parts damage or falling down, resulting in injury due to fragments and falling down.
- When entering or exiting the machine, players may trip over the base or hit their heads on the pipes. Be sure to warn players who do not appear to be exercising proper caution.

- Persons other than the player should not be allowed to touch the controls during play. They may brush against or collide with the controls or the player, possibly resulting in accidents.

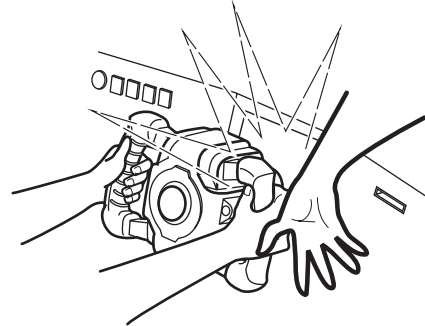

- Players should be warned not to place personal effects or other objects on the base of the machine. If the safety sensor fails to detect these items, the motion of the machine may cause them to fly out and strike other patrons.
- Players should be instructed to adjust the seat by moving it forward or backward to fit their body size before playing the game. Playing the game in an unnatural position can lead to unforeseen accidents.



- When an unjust act is performed, no written data is backed up mechanically.
The following acts may be judged to be unjust acts.
Since it also becomes a defect of operation and the cause of parts damage, caution the player not to perform the following acts.
 - Use of cards bent or deformed
 - Use of cards adhered seals or extraneous matter on
 - Use of a card mixed two sheets
 - Use of cards other than dedicated cards
 - When a card is extracted quickly
- Since the order in which cards are dispensed is random, note that there may be cases in which the same card comes out several times in a row or a certain card fails to come out at all.

If the card reader/writer has not been set as being unused, you will be unable to select any game mode with use of cards while the game will be in progress.

Thus, for the card reader/writer, deal with the player, paying attention to the following points:

Even if the player request the system for use of cards when you have set the machine so that the card reader/writer is not used, the request is rejected because of the nature of the system.

USING MEMORY CARDS

Players who use memory cards should be advised of the following precautions. Data that is damaged or lost cannot be recovered.

- Before inserting a memory card, check to make sure there are no problems with the slot.
- When using a memory card and a license card at the same time, insert the memory card first. Player data will not be used in the game if the cards are inserted in the wrong order.

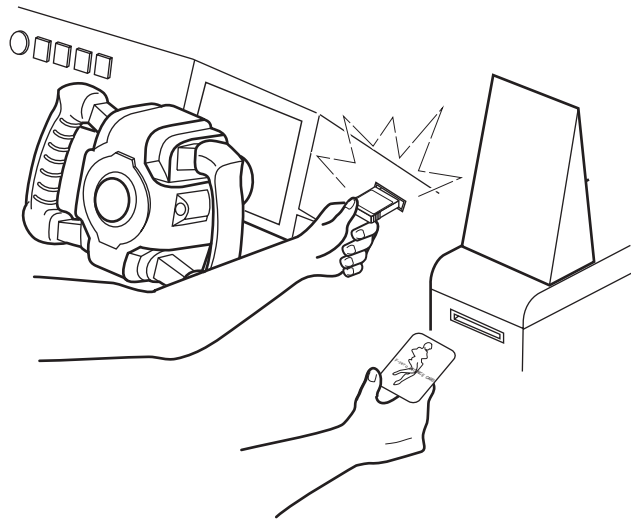
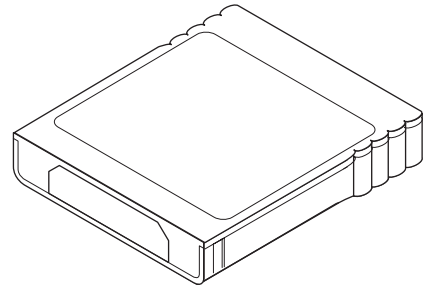

- Be sure to use a memory card containing "F-ZERO GX" game data.
- Never attempt to remove/insert a card during play. Doing so may damage the data.
- Do not use memory cards other than authorized Nintendo products or official licensed products.

4. NAMES OF PARTS

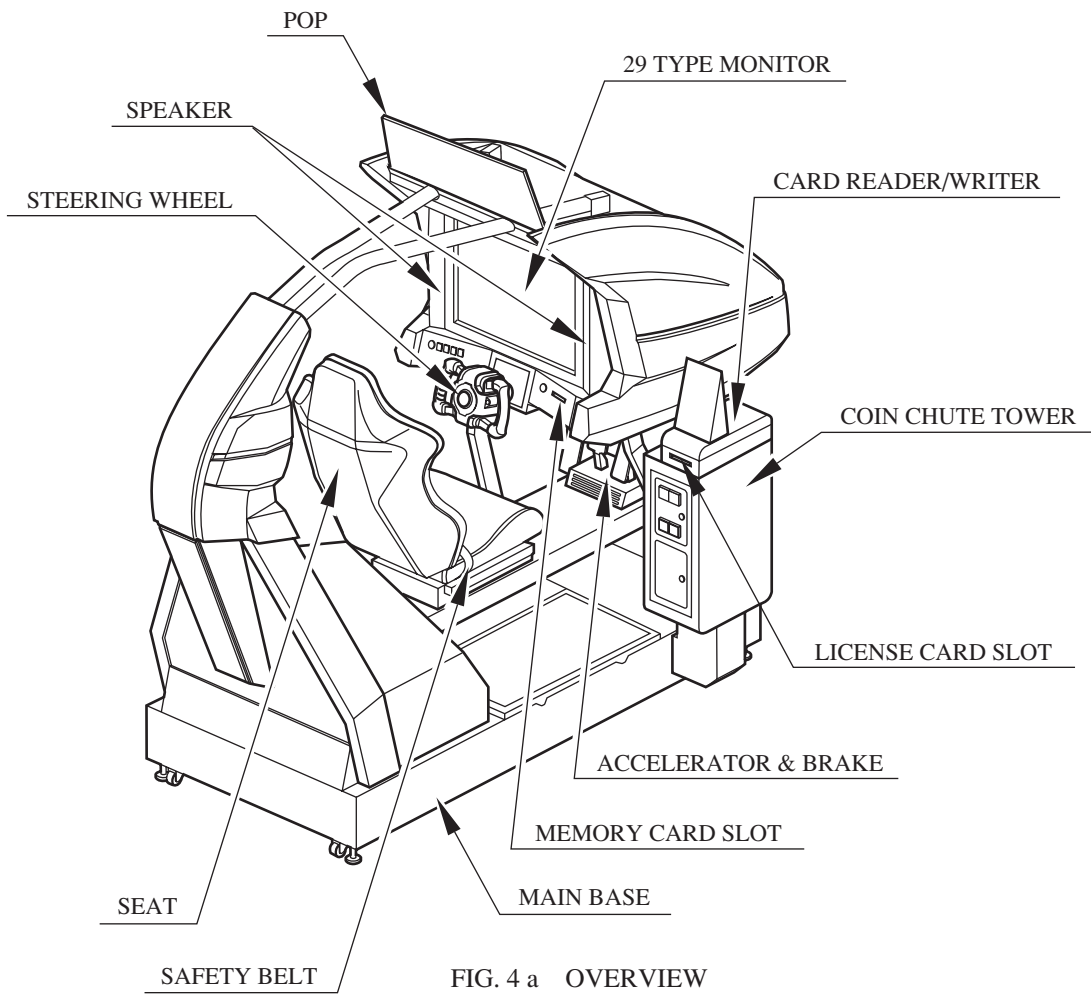

FIG. 4 a OVERVIEW

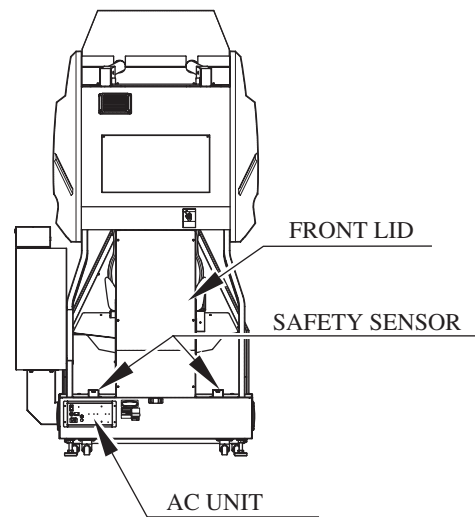

FIG. 4 b FRONT VIEW

TABLE 4 Dimensions and Weights



	Width × Length × Height	Weight
Cabinet w/o POP & Coin Chute Tower	1,020 mm × 2,640 mm × 2,000 mm	502 kg
When assembled	1,200 mm × 2,640 mm × 2,200 mm	527 kg

5. ACCESSORIES

When transporting the machine, make sure that the following parts are supplied. Magnetic cards for the recording of play results, and cleaning kits for cleaning the head of the card reader/writer are sold separately. Subsequent purchases of these items can be made by contacting the office listed on this manual or the dealer from whom the product was originally purchased. Be sure to provide the part number(s), name(s), and required number of items.

- Cleaning Kit
601-11050 CLEANING CARD: Package of 30 sheets
- Magnetic Cards
601-11334-01 CARD PACKAGE FZR ENG: Package of 200 Magnetic Cards

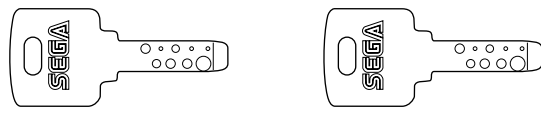
TABLE 5 a ACCESSORIES

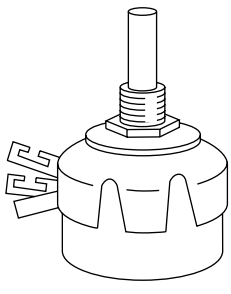
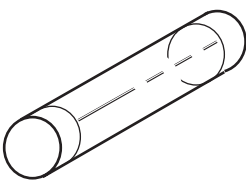
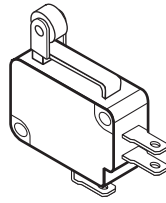
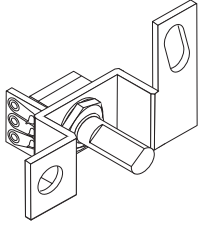
<p>DESCRIPTION OWNERS MANUAL</p> <p>Part No. (Qty.) 420-6769-01 (1)</p> <p>Note</p> <p>Figures</p> <p>NOTE: Parts not labeled with part numbers are as yet unregistered or cannot be registered. Be sure to handle all parts with care, as some parts are not available for purchase separately.</p>	<p>KEY MASTER 220-5576 (2)</p> <p>For opening/closing the doors</p>	<p>KEY (2)</p> <p>For the CASHBOX DOOR</p>
<p>CLEANING CARD 601-11050 (1)</p> <p>For the periodic maintenance. See Sections 7 and 10. (30 sheets of Cleaning Card)</p>	 <p>The Keys are inside the Coin Chute Door at the time of shipment from the factory.</p>	
	<p>VOL CONT B-5K OHM 220-5484 } (1) 220-5753 } Spare, see Sections 11.</p>	
<p>FUSE 10A 125V 514-5036-10000 (1) Spare, see Section 18.</p>		<p>VOL CONT B-10K OHM W/BD 220-5775 (1) Spare, see Sections 11.</p>
		

ASSY FIBER CABLE (NETWORK CABLE) 10 m
 600-7269-1000 (1)
 Used for the Network Play. See Section 20.

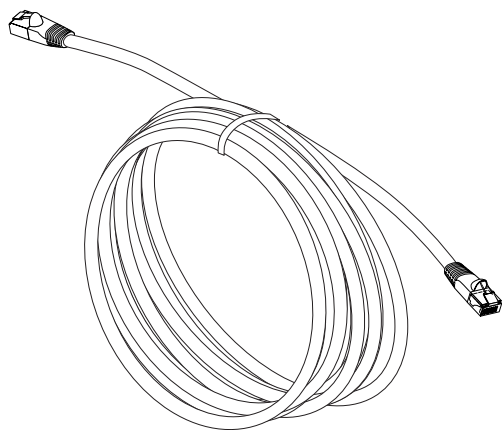

CARTON BOX
 601-11224-01 (1)
 Used for transporting the Game Board.
 See 19-6.

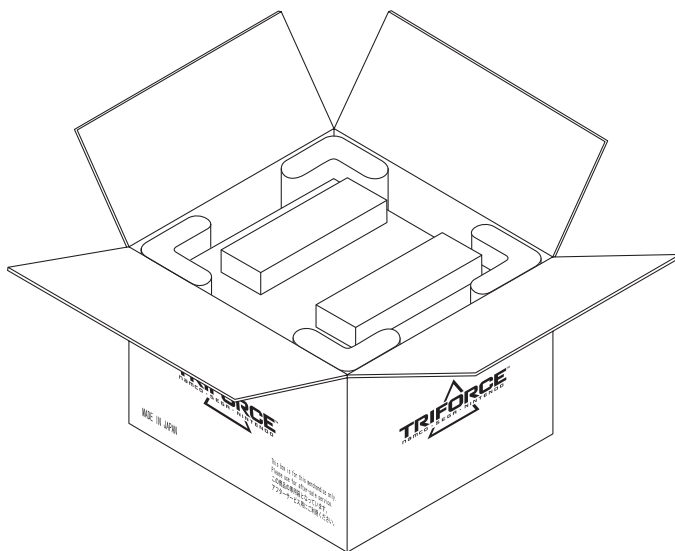

The following Table 5b lists the parts that had been separately packed when the product was shipped from the factory but are necessary when you use the product. These parts will be mounted on the product when installing and assembling it.

TABLE 5 b

POP
 FZR-0013 (1)
 Used for installation. See 1 of Section 6.



POP CARD
 FZR-0020-01 (1)
 Used for installation. See 1 of Section 6.



AC Cable (Power Cord)
 600-7228 } (1) TAIWAN
 600-6729 }
 600-6619-01 (1) HONG KONG
 600-6618 (1) AC 220~240V AREA
 600-6695-01 (1) USA

Used for installation,
 See [4] of Section 6.

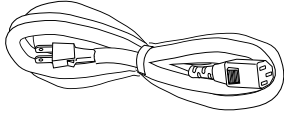

WIRE HARN EARTH W/LUG
 M6
 600-6664-02 (1)
 <For TAIWAN>
 Used for installation,
 See [4] of Section 6.

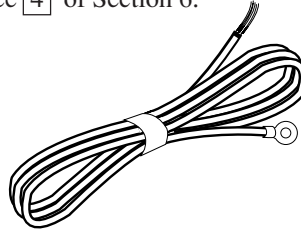

CORD CLAMP
 280-5009-01 (1)
 Used for securing the
 power cord.
 See [4] of Section 6.

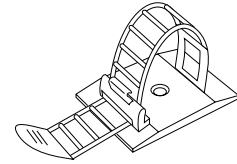

SCREW
 000-P00416-W (3)
 Used for securing the GD-ROM DRIVE.
 See [3] of Section 6.



GD CABLE
 600-7247-500 (1)
 Used for connecting between the GD-ROM Drive
 and the DIMM Board. See [3] of Section 6.

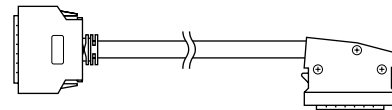

TAPPING SCREW
 012-P00408 (4)
 Used for securing the GD-ROM DRIVE.
 See [3] of Section 6.

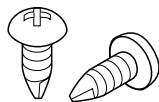

GD DRIVE BRACKET
 105-5435 (1)
 To be mounted on the GD-ROM drive.
 See [3] of Section 6.

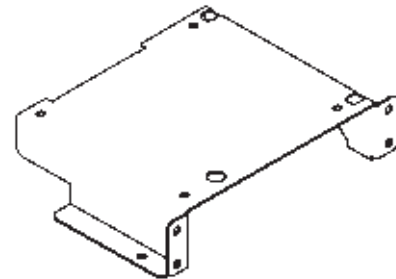

GD SOFT KIT FZR
 610-0650-0007 (1) <ASIA>
 610-0650-0004 (1) <OTHERS>
 GD-ROM software.
 See [3] of Section 6.

CUSHION SPONGE
 601-11137 (1)
 GD-ROM Disc Protector

GD-ROM DISC

DISC CASE
 253-5507

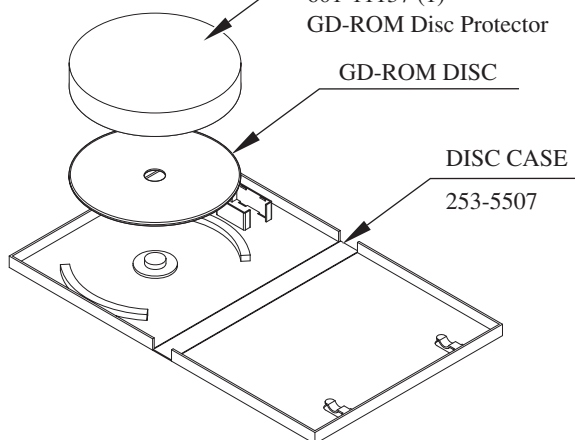

NOTE: When you order the GD-ROM disc only, specify the part number;
 610-0649-0007 (GD SOFT FZR ASIA): ASIA
 610-0649-0004 (GD SOFT FZR): OTHERS

The following Table 5c lists the parts that are separately marketed but are necessary when booting this product's software. When having unpacked the shipping crate, make sure that all the parts in this Table 5c are in the crate. If not so, contact where you have obtained the product.

TABLE 5 c (XKT-0833 : GD-ROM DRIVE KIT)

GD-ROM DRIVE

610-0617 }
610-0617-01 } (1)

Device that loads the software in a GD-ROM disc.
See 6 of Section 6.

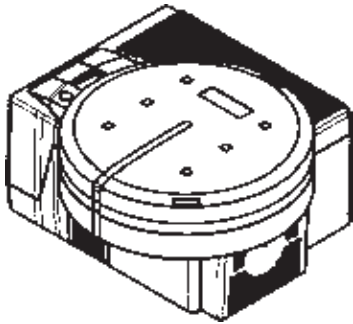

GD-ROM DRIVE CARTON BOX (1)

Used for transporting the GD-ROM DRIVE.
See 19-6.

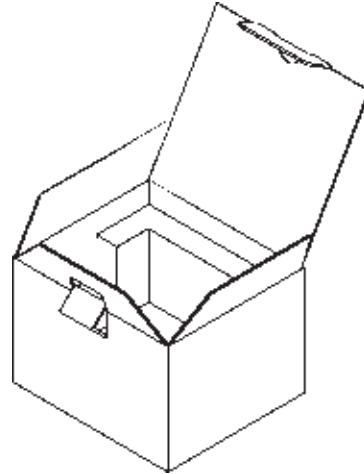

This carton box is a standard accessory of the GD-ROM drive. If you want to obtain the carton box itself separately, specify the part number 601-11031.

6. ASSEMBLY AND INSTALLATION



- Perform assembly work by following the procedure herein stated. Failing to comply with the instructions can cause electric shock hazard.
- Perform assembling as per this manual. Since this is a complex machine, erroneous assembling can cause an electric shock, machine damage and or not functioning as per specified performance.
- When assembling, be sure to use plural persons. Depending on the assembly work, there are some cases in which working by one person alone can cause personal injury or parts damage.
- Ensure that connectors are accurately connected. Incomplete connections can cause electric shock hazard.
- Be careful not to damage the wires. Damaged wires may cause electric shock or short circuit or present a fire risk.
- This work should be performed by the site maintenance individual or other skilled professional. Performing work by non-technical personnel can cause a severe accident such as electric shock. Failing to comply with this instruction can cause a severe accident such as electric shock to the player during operation.
- Provide sufficient space so that assembling can be performed. Performing work in places with narrow space or low ceiling may cause an accident and assembly work to be difficult.
- To perform work safely and avoid serious accident such as the cabinet's falling down, do not perform work in places where step-like grade differences, a ditch, or slope exist.
- The seat will continue to move even if it comes into contact with persons other than the player. In order to ensure a safe operating environment, place the machine so that one side is adjacent to the back of another game machine or to the wall.
- If the machine is placed so that people will be passing through the vicinity, leave at least 70 cm of space around the machine. If this space is too narrow, persons other than the player may brush against or collide with the machine, possibly resulting in accidents.
- Do not leave power cords, grounding wires, or network cables exposed in areas of heavy foot traffic. Doing so may cause them to become damaged, possibly resulting in electric shock and/or short circuits. When laying wiring across the floor, always use safety covers to protect the wires. (Wiring diameter: power cable - approx. ϕ 8; network cable - approx. ϕ 5)



- Handle molded parts with care. Undue weight or pressure may cause them to break and the broken pieces may cause injury.
- To perform work safely and securely, be sure to prepare a step which is in a secure and stable condition. Performing work without using the step can cause violent falling down accidents.
- Make sure that the GD cable connector is inserted parallel to the plug. Improper insertion may cause damage to the connector and present a fire risk.

When carrying out the assembling and installation, follow the following 6-item sequence.

- 1 INSTALLING THE COIN CHUTE TOWER, AND THE POP/POP CARD
- 2 SECURING IN PLACE (ADJUSTER ADJUSTMENT)
- 3 INSTALLING THE GD-ROM DRIVE (SETTING THE GD-ROM DISC)
- 4 POWER SUPPLY, AND EARTH CONNECTION
- 5 TURNING THE POWER ON
- 6 ASSEMBLING CHECK

The master key (accessories) in addition to the tools such as a Phillips type screwdriver and wrench are required for the assembly work.

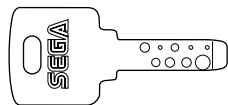

KEY MASTER

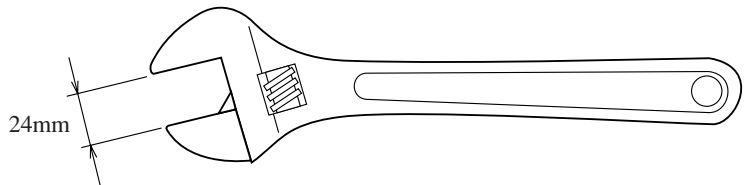

WRENCH (for M16 hexagon-head bolt)

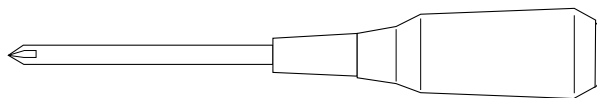

Phillips type screwdriver

1

INSTALLING THE COIN CHUTE TOWER, AND THE POP/POP CARD

INSTALLING THE COIN CHUTE TOWER

- ① First, remove the cash box and then close and relock the cash box door. Accidents may occur if the door is free to swing open or closed.
- ② Spread a blanket or other soft surface on the floor next to where the coin chute tower is to be installed, and place the coin chute tower on top.



PHOTO 6. 1 a

- ③ Plug in the 3 wire connectors linking the coin chute tower and the base.

Connect the connector (3)

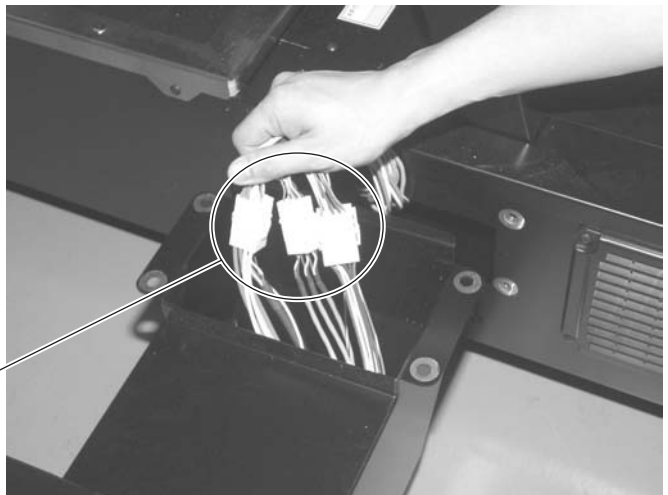

PHOTO 6. 1 b

- ④ Install 6 hexagonal bolts on the pillar side of the coin chute tower. Taking care not to damage the wiring, have one person support the coin chute tower while another installs the bolts.

HEXAGONAL BOLT (2), black
M8×50, w/spring washer, flat washer used

HEXAGONAL BOLT (4), black
M8×20, w/spring washer,
flat washer used

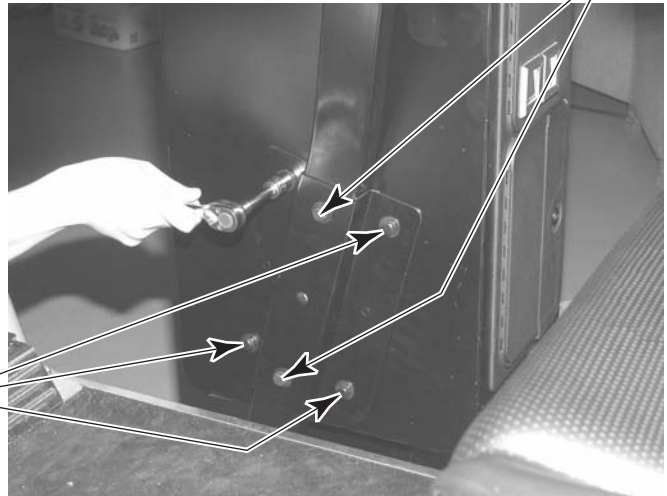

PHOTO 6.1 c

HEXAGONAL BOLT (4), black
M8×20, w/spring washer, flat washer used

- ⑤ Install 4 hexagonal bolts on the bottom of the coin chute tower.

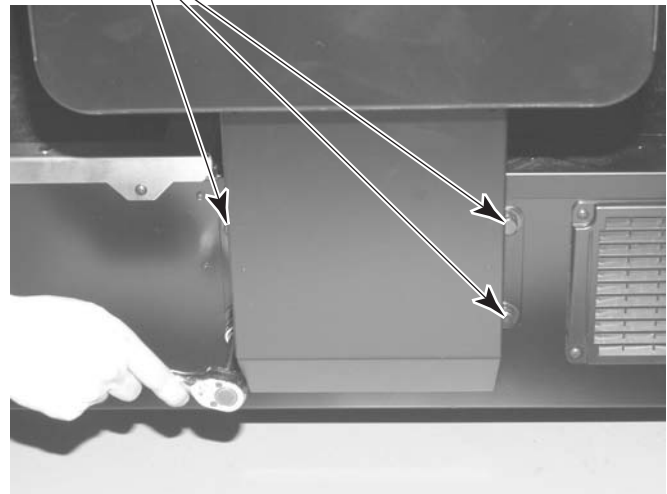

PHOTO 6.1 d

HEXAGON NUT (2)
M6, flat & spring washers used

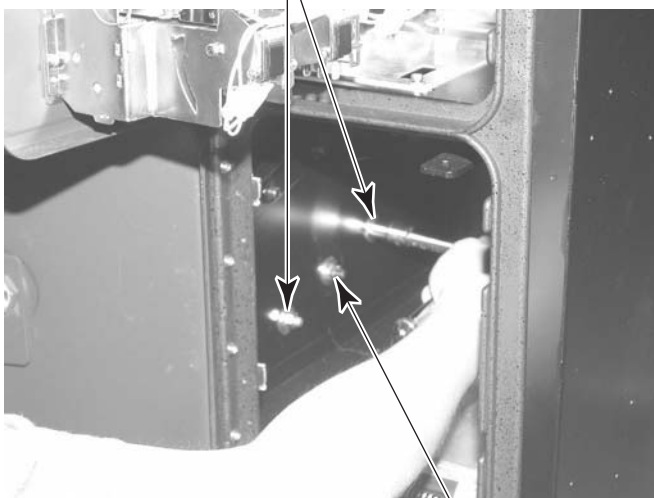

PHOTO 6.1 e

- ⑥ Unlock the coin chute and cash box doors and install 3 hexagon nuts on the base side of the interior of the cash box door.
- ⑦ Return the cash box to its original position and lock the door.

INSTALLING THE POP AND THE POP CARD

- ① Plug the POP into the ceiling of the monitor box.
- ② Tighten the 3 truss screws.

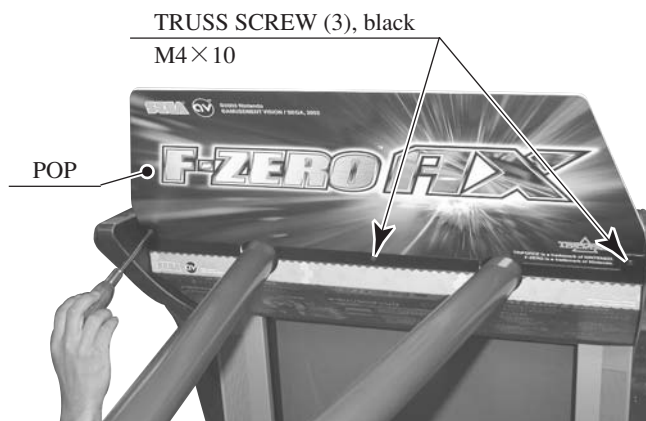

PHOTO 6. 1 f

- ③ Assemble the POP card as shown in the diagram and attach it to the card reader/writer.

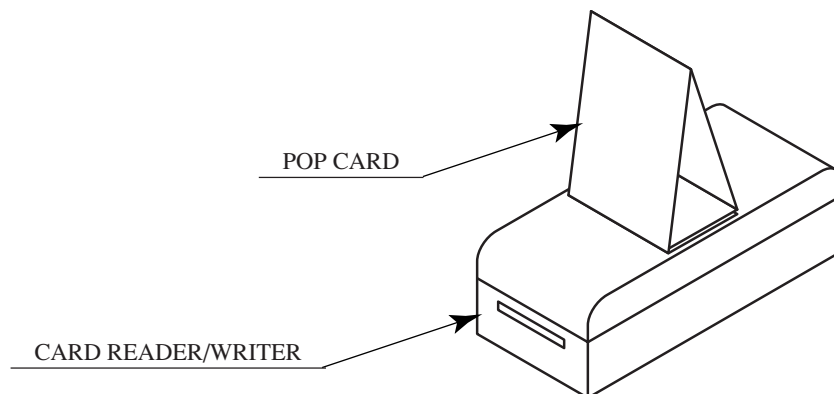

FIG. 6. 1

2

SECURING IN PLACE (ADJUSTER ADJUSTMENT)



Make sure that all of the adjusters are in contact with the floor. If they are not, the cabinet can move and cause an accident.

This product has 6 casters and 4 Adjusters. (FIG. 6. 2 a) When the installation position is determined, cause the adjusters to come into contact with the floor directly, make adjustments in a manner so that the casters will be raised approximately 5 mm from the floor and make sure that the machine position is level.

- ① Transport the product to the installation position.
- ② Have all of the Adjusters make contact with the floor. Adjust the Adjuster's height by using a wrench so that the machine position is kept level.
- ③ After making adjustment, fasten the Adjuster Nut upward and secure the height of Adjuster.

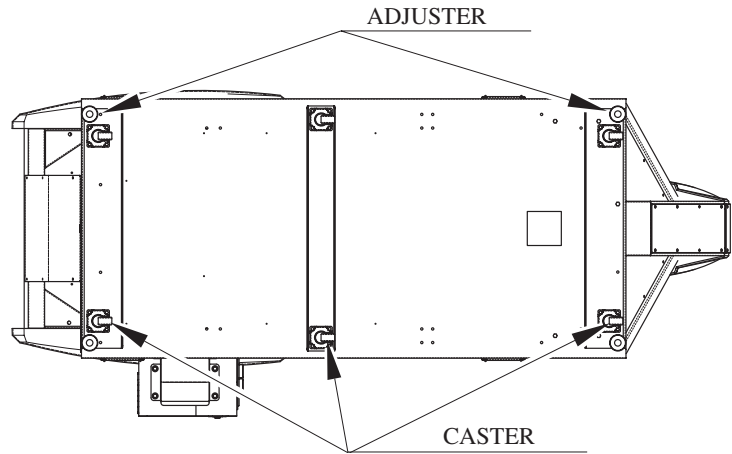

FIG. 6. 2 a BOTTOM VIEW

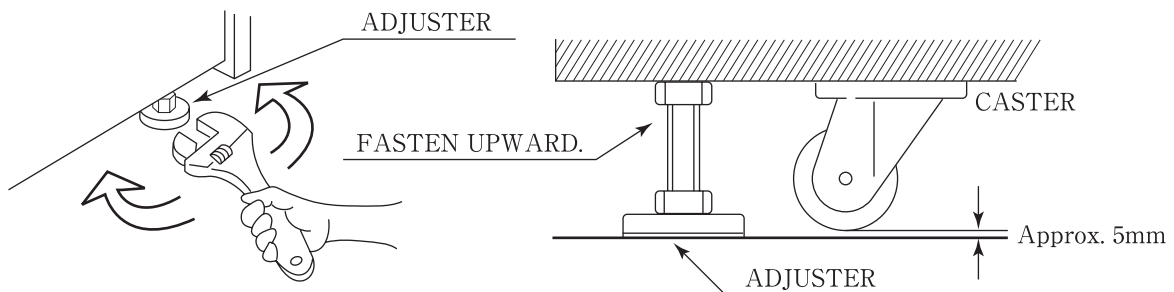

FIG. 6. 2 b ADJUSTER

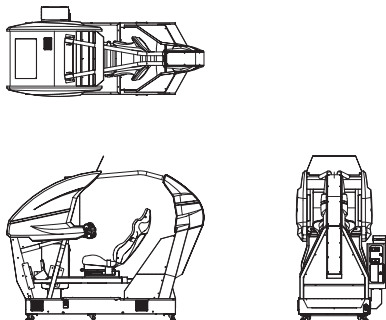

FIG. 6. 2 c
Refer to this Fig. (Scale:1/100)
for the layout of the place of
installation.

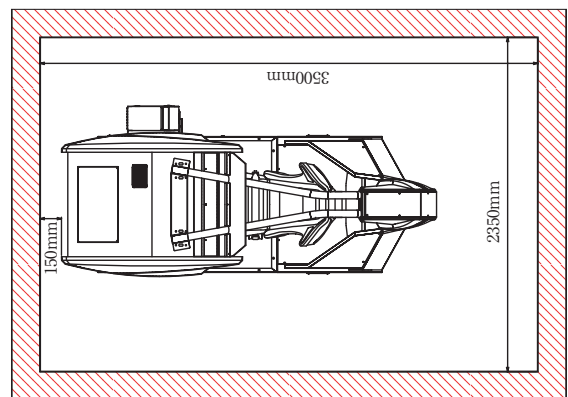

FIG. 6. 2 d
Provide ventilation space for the ventilation
opening.
Allow more than 70 cm (approx. 28 in)
of space for customer traffic.

3

INSTALLING THE GD-ROM DRIVE (SETTING THE GD-ROM DISC)



- Carefully handle the GD-ROM drive so as not to contaminate the disc and the readout lens with stains and dust particles.
- Do not continue to use the scratched GD-ROM disc. The scratched GD-ROM disc may cause the system to malfunction.
- Set the GD-ROM disc onto the GD-ROM drive with its labeled side facing upward.
- The key chip is a precision device. Handle it carefully and avoid exposure to heat, shock and static electricity, as these may cause damage to the device.
- The key chip is contained in the GD-ROM disc case. Always use them as a set.

- ① Unpack the shipping crate, and take out the GD-ROM drive, GD-ROM drive bracket, and GD-ROM disc.

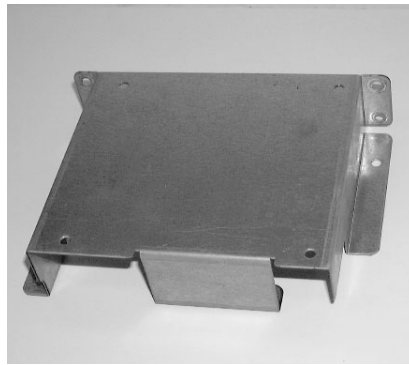

GD DRIVE BRACKET



GD-ROM DRIVE

PHOTO 6. 3 a

- ② Use the 4 tapping screws to fix the GD-ROM drive bracket onto the GD-ROM drive. Be careful about a fixing direction.

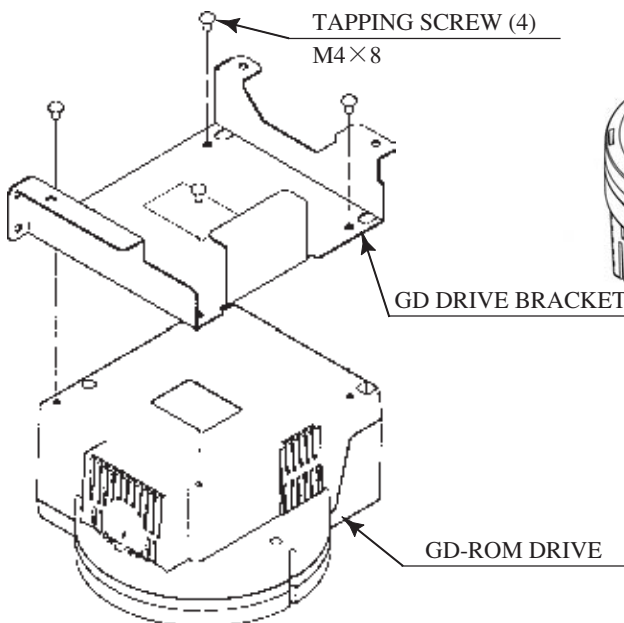
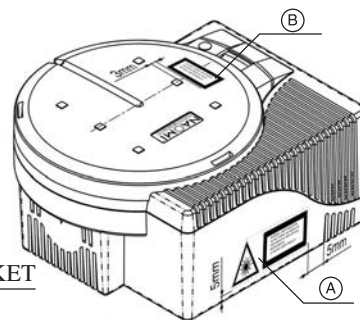
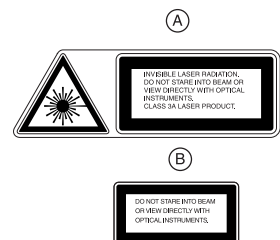

FIG. 6. 3 a



Application diagram



Please follow the drawing and place the sticker with the right language.

FIG. 6. 3 b

CAUTION for U. S. A., Europe, and Australia:
Attach the 2 caution stickers for a laser ray onto the GD-ROM drive.

- ③ Remove the 1 truss head screw that fixes the GD-ROM drive lid (DISC LID). And turn clockwise the lid to remove.

TRUSS SCREW (1)
M3×8

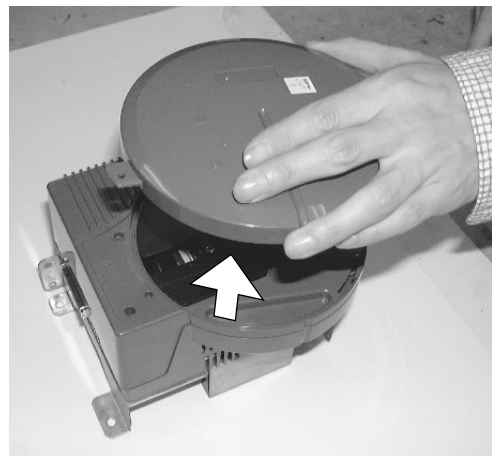
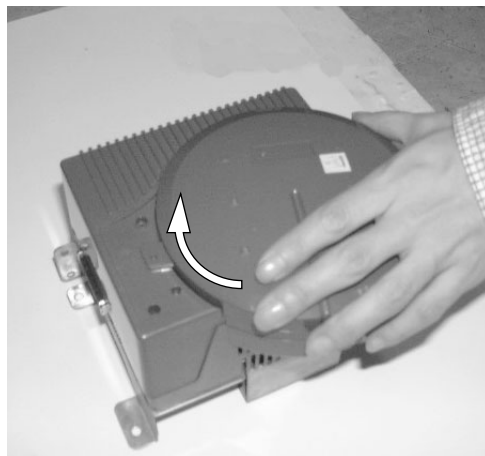
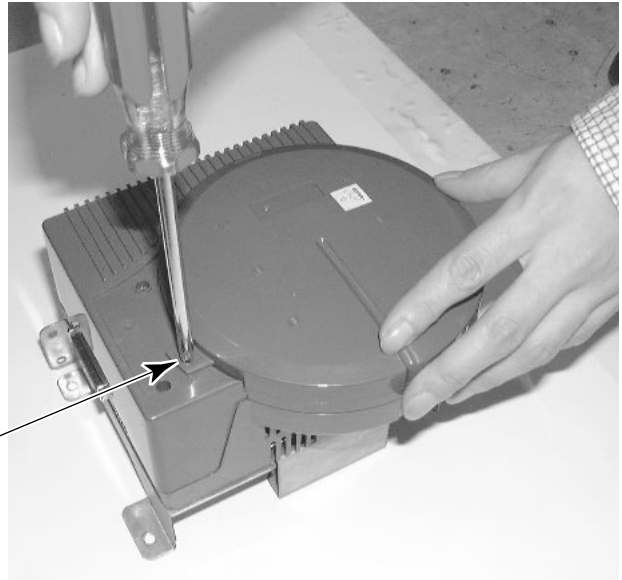

PHOTO 6.3 b

- ④ Set the GD-ROM disc onto the GD-ROM drive with its labeled side facing upward.
- ⑤ Return the lid to its original place, and fix it with 1 truss head screw. Be careful not to fasten the screw too tightly.

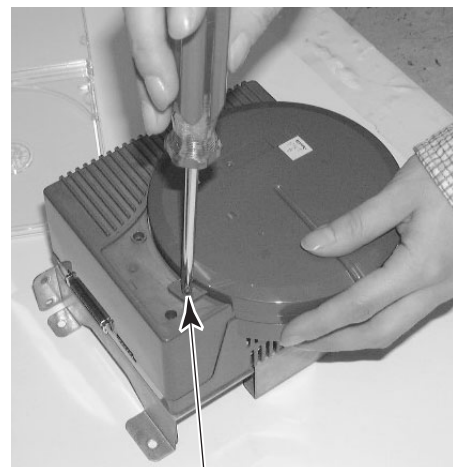

PHOTO 6.3 c

TRUSS SCREW (1)
M3×8

- ⑥ Remove Floor R from the coin chute tower side of the base.
Unlock it and remove the 2 truss screws.

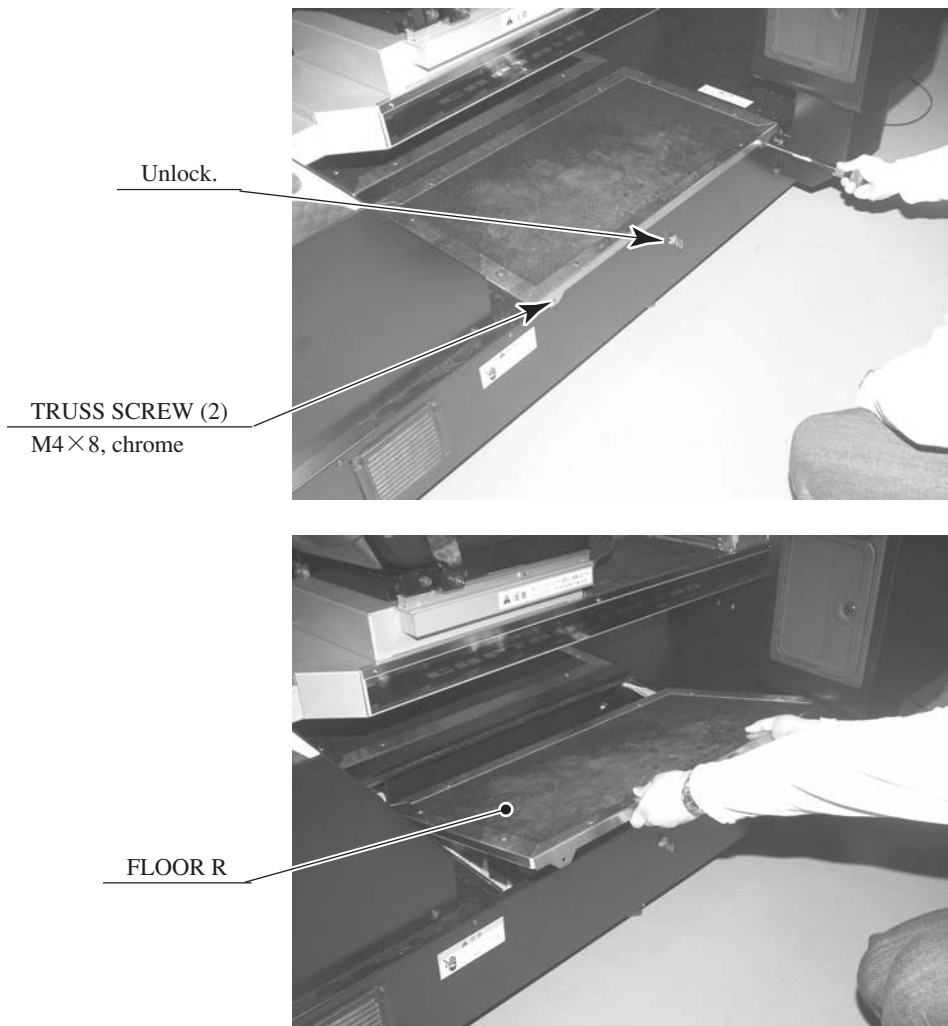

PHOTO 6. 3 d

- ⑦ Affix the GD-ROM drive with 3 screws.

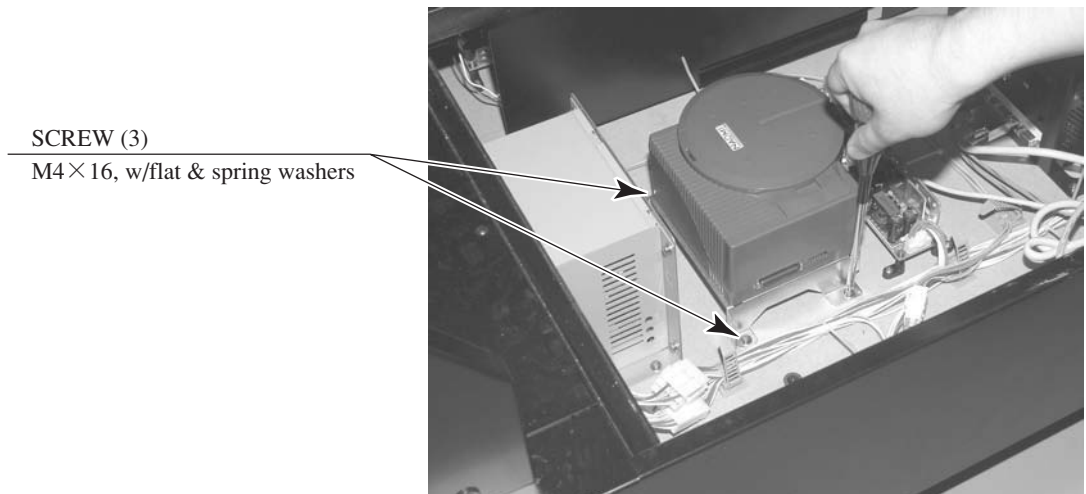

PHOTO 6. 3 e

- ⑧ Connect the power cable connector to the GD-ROM drive. The GD-ROM drive power cable will already be attached to the inside of the base. Plug the connector in securely, making sure it is connected in the proper direction.

GD-ROM DRIVE

POWER CABLE CONNECTOR
JST NH6P

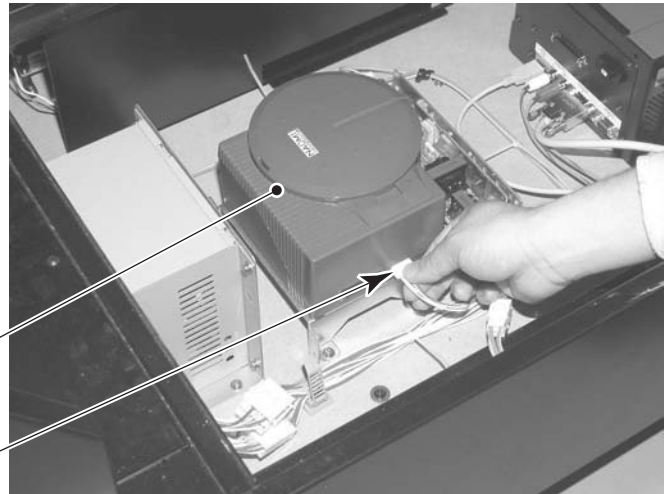

PHOTO 6.3 f

- ⑨ Connect the GD cable to the GD-ROM drive and the TRIFORCE board. Plug the connectors in securely, making sure they are connected in the proper direction.

TRIFORCE BOARD

GD-ROM DRIVE

GD CABLE

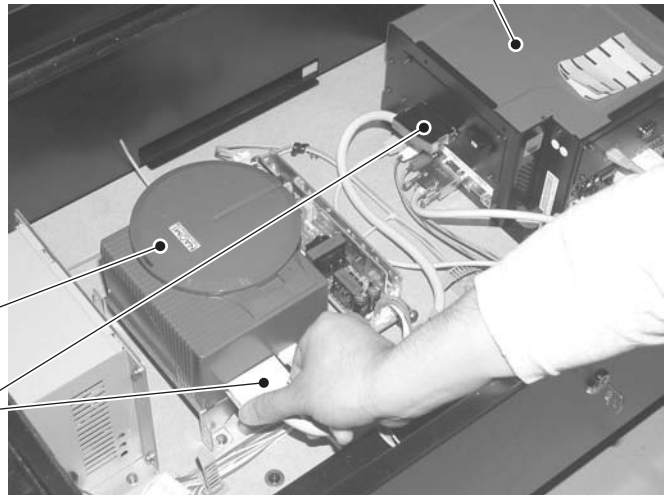

PHOTO 6.3 g

- ⑩ Unfasten the 2 cord clamps that are holding the wiring inside the base in place, place the GD cable in the clamps with the other wires, and secure the clamps again.

CORD CLAMP

GD CABLE

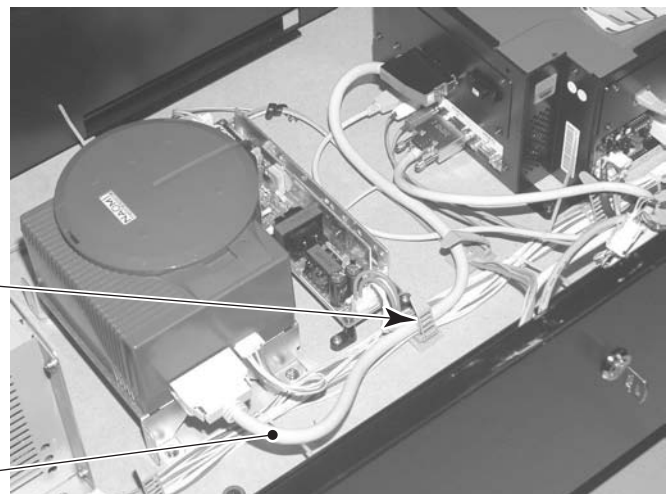

PHOTO 6.3 h

4

POWER SUPPLY, AND EARTH CONNECTION



- Be sure to independently use the power supply socket outlet equipped with an Earth Leakage Breaker. Using a power supply without an Earth Leakage Breaker can cause a fire when electric leakage occurs.
- Ensure that the "accurately grounded indoor earth terminal" and the earth wire are available (except in the case where a power cord plug with earth is used). This product is equipped with the earth terminal. Connect the earth terminal and the indoor earth terminal with the prepared cable. If the grounding work is not performed appropriately, customers can be subjected to an electric shock, and the product's functioning may not be stable. <For Taiwan>
- Ensure that the power cord and earth wire are not exposed on the surface (passage, etc.). If exposed, they can be caught and are susceptible to damage. If damaged, the cord and wire can cause electric shock and short circuit accidents. Ensure that the wiring position is not in the customer's passage way or the wiring has protective covering.
- After wiring power cord on the floor, be sure to protect the power cord. Exposed power cord is susceptible to damage and causes an electric shock accident.

The AC Unit is located on one side of Monitor on the Base. The AC Unit has Main SW, Earth Terminal and the Inlet which connects the Power Cord.

- ① Ensure that the Main SW is OFF.

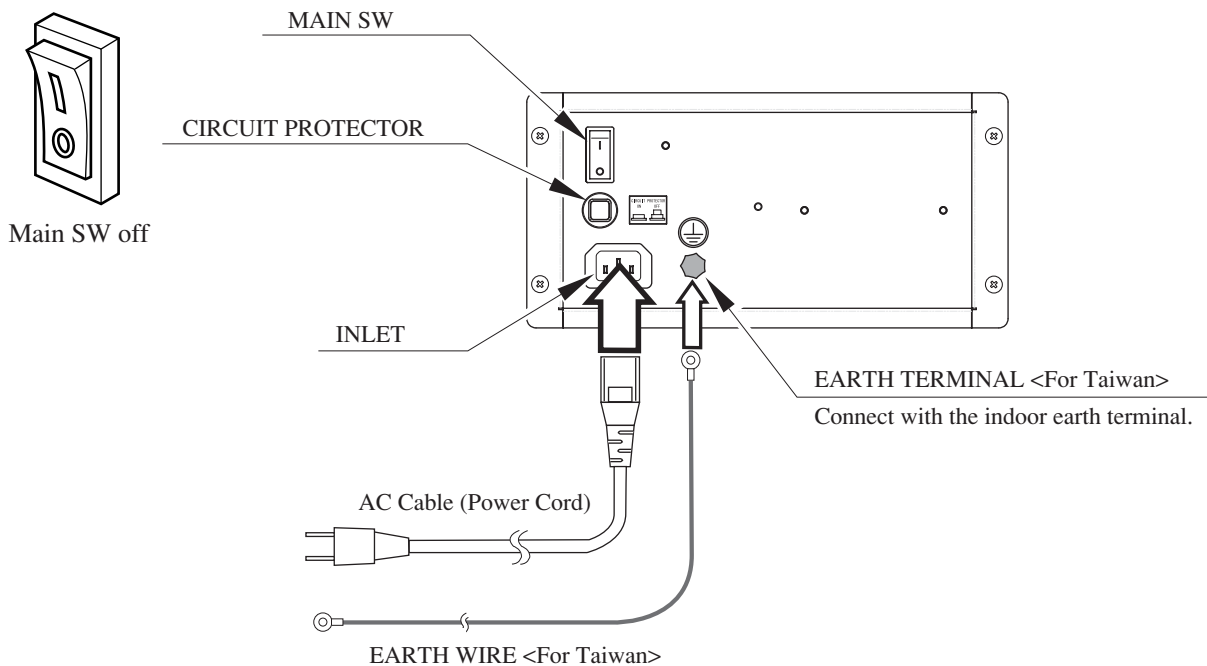

FIG. 6. 4 a AC UNIT

- ② Connect one end of the earth wire to the AC Unit earth terminal, and the other end to the indoor earth terminal. The AC Unit earth terminal has a Bolt and Nut combination. Take off the Nut, pass the end of earth wire through the Bolt, and fasten the Nut. <For Taiwan>

*Note that the Earth Wire is incorporated in the Power Cord for the Areas of AC 120 V (USA) and AC 220 ~ 240 V, and therefore, this procedure is not necessary.

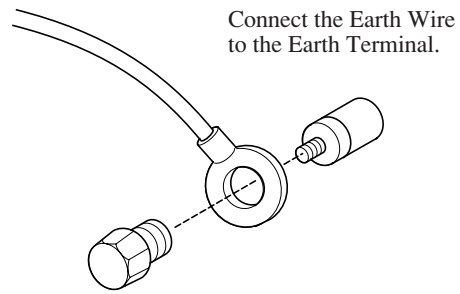

FIG. 6. 4 b *Earth Wire Connection

- ③ Firmly insert the power plug into the socket outlet. Insert the opposite side of Power Cord plug to the AC Unit's connector ("INLET").
- ④ Perform wiring for the Power Cord and Earth Wire. Install protective covering for the Power Cord and Earth Wire.

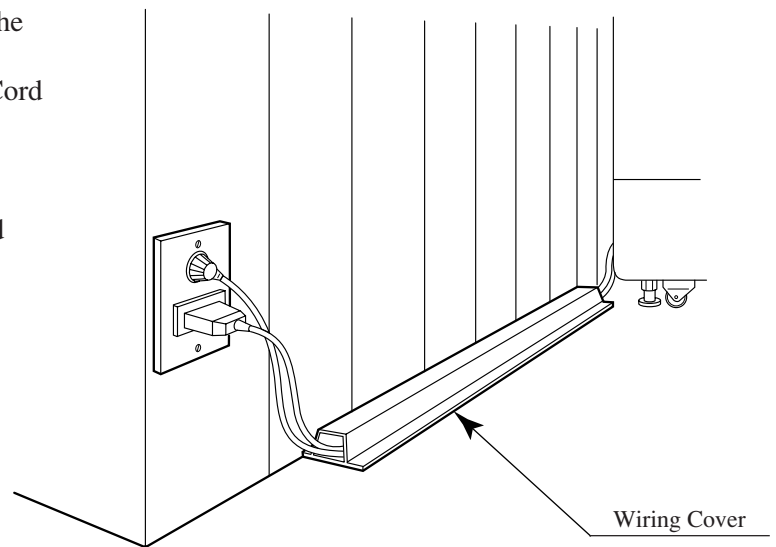
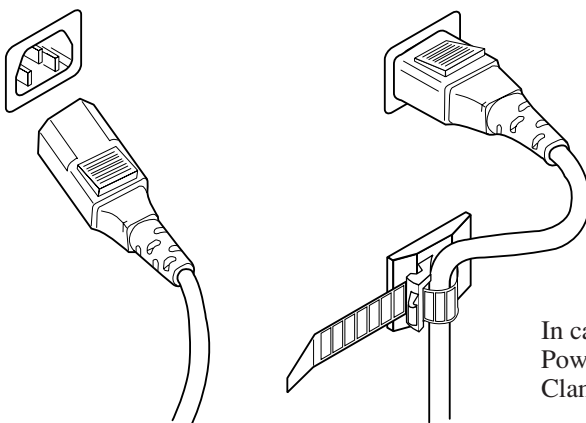

FIG. 6. 4 c Connecting Power Cord and Earth Wire



HOW TO USE THE CORD CLAMP

In case the Power Plug is apt to come out of place, secure the Power Cord to the periphery of the AC Unit with the Cord Clamp (an accessory).

5

TURNING THE POWER ON



Make sure the surrounding area is secure before turning the power on. The machine will automatically go through an initialization process after being turned on. The seat will move left and right, and persons standing in the vicinity of the machine may be struck or knocked down.



Do not touch the machine until it has completed the initialization process and the advertising screen has appeared. Doing so may cause the person touching the machine to be struck by the seat. It may also prevent the machine from initializing properly. Failure to initialize properly can lead to control malfunction and other problems.

Turn the main switch on the AC unit ON to turn on the power. The 2 fluorescent lamps will light up when the power is turned on.

After displaying the system startup screen, the monitor will indicate that the card reader/writer and motor, in that order, are being tested.

Next, the initialization screen will be displayed, and the initialization process will begin.

Initialization consists of the following steps, with each part moving and coming to rest in the preset position and direction automatically.

- 1) The seat moves left and right.
- 2) The seat comes to rest in a level position.
- 3) The steering wheel rotates left and right.
- 4) The steering wheel comes to rest in a 12 o'clock position.

When the initialization process is complete, the machine will go into Advertising mode. The monitor will display the demo screen, and the speakers to the left and right of the monitor and on the left and right of the seat's headrest will begin sound output. If the "no sound during Advertising mode" option is selected, sound output will be turned off.

When a sufficient number of credits have been inserted, the "Start" button on top of the control panel will flash. After the race begins, the "View Change" button for the currently selected mode will light up. The buttons will not be lit up during Advertising mode when no credits have been inserted.

After displaying the initialization screen, if the machine is set for network play, the monitor will indicate that the network is being tested.

If there are no problems with the network play connection and settings, the machine will enter Advertising mode.

If there is a problem with game board system, an error message will be displayed on the screen. If there is a problem with steering unit response or seat motion, an error message will be displayed. Refer to the on-screen error message to locate and resolve the problem.

If, after the initialization process is complete, the seat comes to rest at an angle or the steering unit comes to rest in a position other than straight, turn the power off and back on and have the machine go through initialization again.

If the seat or steering unit continues to come to rest at an angle after going through initialization again, there is likely a problem such as bad VR settings or a glitch in the initialization process. Refer to the drive board's 7-seg display to locate and resolve the problem.

If there are any defects or abnormalities in the network play connection or settings, the machine will continue to display the network test screen. Check the network play cable connection and settings.

The machine will save the number of credits inserted and rankings data even when the power is turned off. Fractions of credits (i.e. any coins inserted that do not add up to a full credit) and bonus adder count data will not be saved.

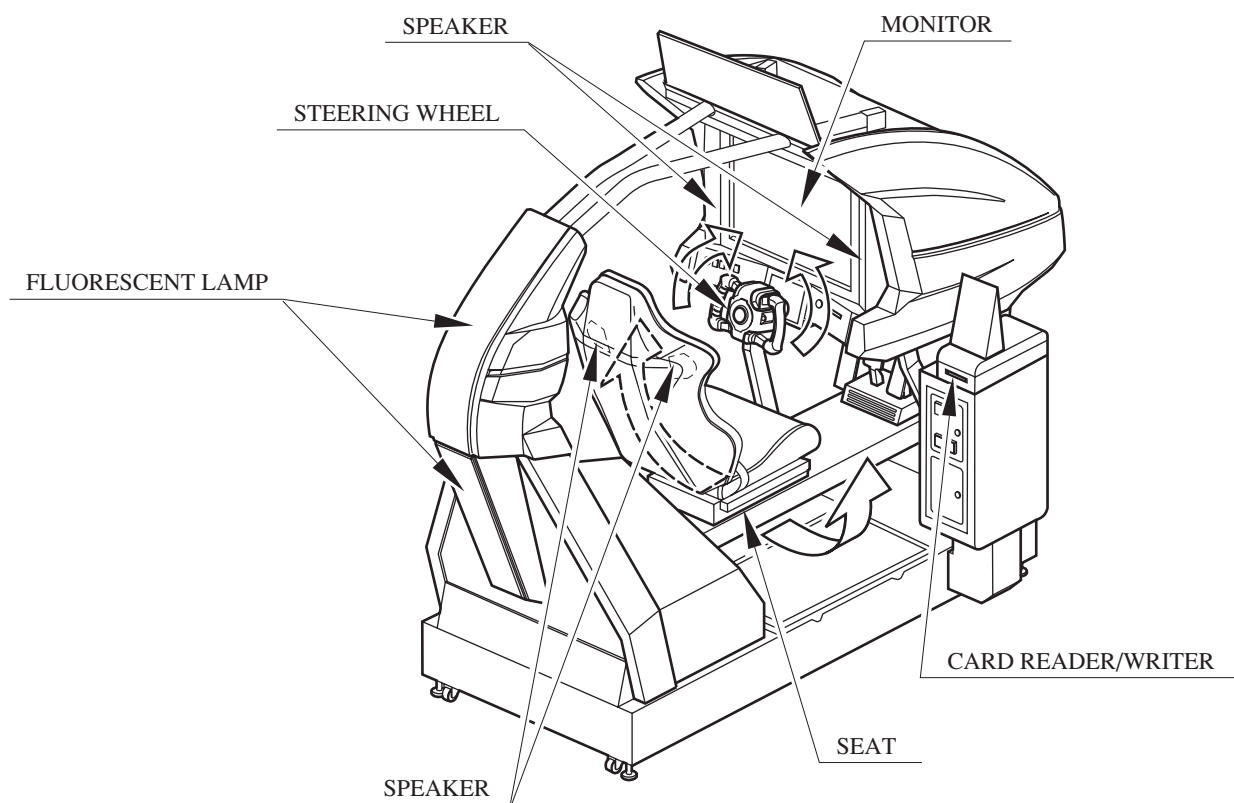

FIG. 6. 5

6

ASSEMBLY CHECK

In the TEST MODE, ascertain that the assembly has been made correctly and IC BD. is satisfactory (refer to Section 10).

In the test mode, perform the following test:

(1) MEMORY TEST

Selecting RAM TEST or MEDIA BOARD TEST from the menu screen in System Test mode will cause the machine to automatically perform a test of the memory on the game boards. If "GOOD" is displayed next to the number of each memory segment, the game boards are working properly.

Select SYSTEM INFORMATION to display information on the main game board and the media board. If the information is displayed correctly, this indicates that the game boards are functioning properly.

```
RAM TEST

AUX MEMORY    GOOD

PRESS TEST BUTTON TO EXIT
```

```
MEDIA BOARD TEST  1/2

DOMM BOARD(TYPE 3)
VERSION  ****
STATUS   GOOD
CHECKING 100%

DIMM TEST
DIMM0    - GOOD
DIMM1    - NONE
GD-ROM   - GOOD

PRESS TEST BUTTON TO EXIT
```

```
MEDIA BOARD TEST  2/2

NETWORK BOARD
VERSION  ****
STATUS   GOOD
CHECKING 100%

NETWORK BOARD TEST
RAM CHECK _ GOOD
-- COMPLETED --

PRESS TEST BUTTON TO EXIT
```

```
SYSTEM INFORMATION

MAIN BOARD
REGION      ****
BOOT VERSION ****
FIRM VERSION ****
FPGA VERSION ****
SERIAL NO. *****

MEDIA BOARD
DIMM BOARD(TYPE 3)+ GDROM
MEMORY SIZE 512MB
FIRM VERSION ****
SERIAL NO. *****
NETWORK BOARD
FIRM VERSION ****

PRESS TEST BUTTON TO EXIT
```

(2) INPUT TEST

Select INPUT TEST from the menu screen in either System Test mode or Game Test mode to bring up a test screen for the input devices.

Test the input on each device. If "ON" is displayed next to each device as it is tested and the numbers change smoothly in accordance with the input, the input devices and their wiring connections are working properly.

```

                JVS TEST
                INPUT TEST

NODE           1/1
SYSTEM        00
PLAYER 1      0000
PLAYER 2      0000
COIN 1        0000
COIN 2        0000
ANALOG 1      0000
ANALOG 2      0000
ANALOG 3      0000
ANALOG 4      0000
ANALOG 5      0000
ANALOG 6      0000
ANALOG 7      0000
ANALOG 8      0000

PRESS TEST AND SERVICE BUTTON TO EXIT
```

```

                INPUT TEST

STEERING X    0(~FF)      SEAT MOTION    0(~FF)
STEERING Y    0(~FF)      MOTION STOP   OFF(ON)
PADDLE LEFT   OFF(ON)     SEATBELT      OFF(ON)
PADDLE RIGHT  OFF(ON)     SENSOR LEFT   OFF(ON)
BOOST         OFF(ON)     SENSOR RIGHT  OFF(ON)
GAS           0(~FF)     SERVICE       OFF(ON)
BRAKE         0(~FF)     TEST          OFF(ON)
START BUTTON
VIEW CHANGE 1 OFF(ON)
VIEW CHANGE 2 OFF(ON)
VIEW CHANGE 3 OFF(ON)
VIEW CHANGE 4 OFF(ON)

PRESS TEST AND SERVICE BUTTON TO EXIT
```

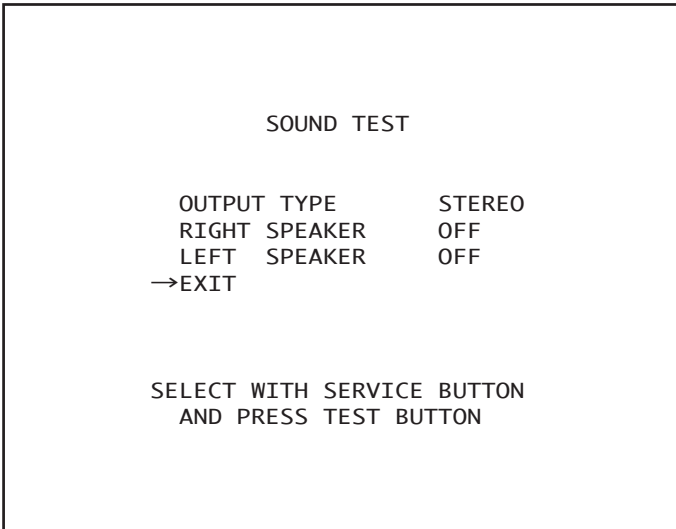

(3) SOUND TEST



In the system test mode, selecting SOUND TEST causes the screen (on which sound related BD and wiring connections are tested) to be displayed.

Check if the sound is satisfactorily emitted from each speaker and the sound volume is appropriate.

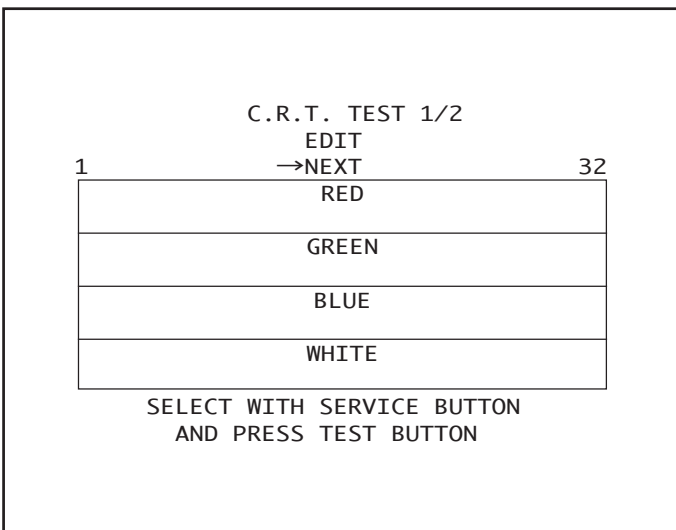
(4) C.R.T. TEST



In the system test mode menu, selecting C.R.T. TEST allows the screen (on which the monitor is tested) to be displayed. Although the monitor adjustments have been made at the time of shipment from the factory, color deviation, etc., may occur due to the effect caused by geomagnetism, the location building's steel frames and other game machines in the periphery. By watching the system test mode screen, make judgment as to whether an adjustment is needed. If it is necessary, adjust the monitor by referring to Chapter 15.

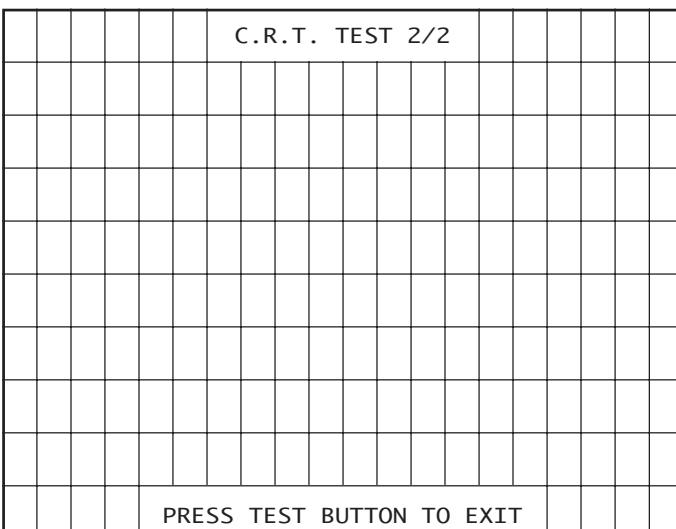

(5) OUTPUT TEST

OUTPUT TEST	
START BUTTON	OFF(ON)
VIEW CHANGE 1	OFF(ON)
VIEW CHANGE 2	OFF(ON)
VIEW CHANGE 3	OFF(ON)
VIEW CHANGE 4	OFF(ON)
BOOST	OFF(ON)
STEERING	
CENTER	OFF(ON)
LEFT	OFF(ON)
RIGHT	OFF(ON)
SEAT	
LOCK	OFF(ON)
CENTER	OFF(ON)
LEFT	OFF(ON)
RIGHT	OFF(ON)
-> EXIT	
SELECT WITH SERVICE BUTTON AND PRESS TEST BUTTON	

Select OUTPUT TEST from the menu screen in Game Test mode to bring up a test screen for the output devices (lamps, etc.) If each output device activates correctly, the output devices and their wiring connections are working properly.

Perform the above inspections also at the time of monthly inspection.

7. CARD READER/WRITER

7-1 SETTING DEDICATED CARDS



- Be sure to use dedicated cards available for this product. Use of ones other than such dedicated cards may cause a malfunction or failure of the machine.
- Be sure to set the specified number of card in the specified orientation by using the specified procedure. Wrong setting of the cards may cause the machine to fail.
- This machine allows you to set up to 100 cards at a time. You must not set over 101 cards at a time. If you do so, a trouble such as card jamming may occur.
- Set virgin cards taken out from a container that was unpacked immediately before use.
- Use of any deformed or deteriorated card may cause a trouble.
- Do not include a corrugated, bent, or used card in the card deck.

When the unit is out of cards, a message will be displayed at the center of the screen. Follow the instructions below to restock the system with cards. Cards may be stocked when the unit is on or off.

- ① Remove the truss screw.
- ② Unlock and open the cover to find the card reader/writer.
The dispenser on which you should place the cards is located at the rear of the reader/writer.
- ③ From the card reader/writer, take out the dispenser upward in a straight line.

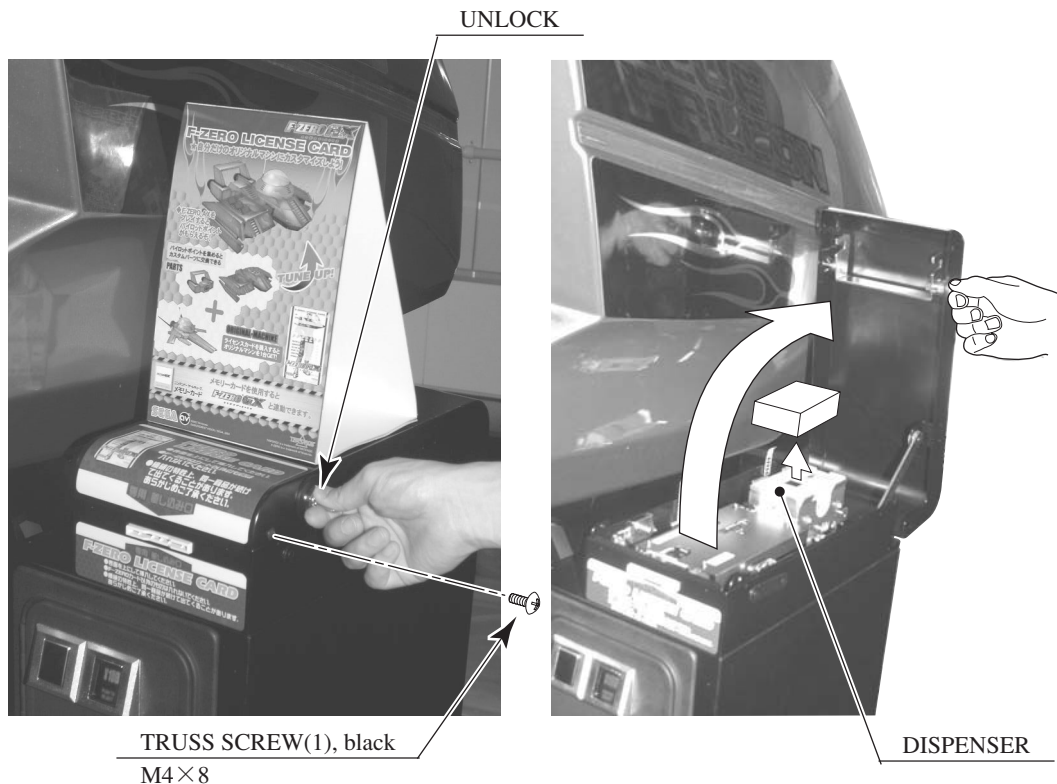

PHOTO 7.1

- ④ Remove the cover from the back of the dispenser.

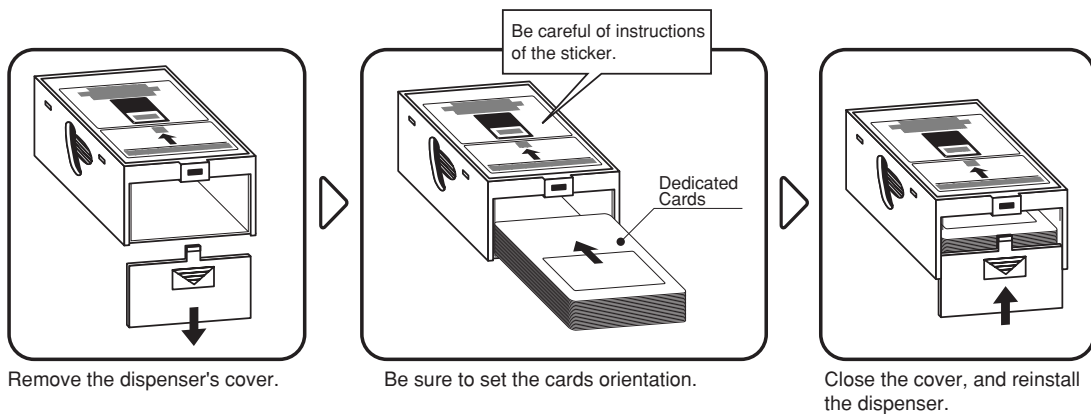

FIG. 7. 1 a

- ⑤ Place the cards into the dispenser according to the instructions on the sticker annexed to the dispenser. Refer to the diagram shown on the sticker attached to the Dispenser and insert the cards into the Dispenser. Be careful not to insert the cards in the wrong direction or with the wrong side facing up.

The Dispenser can only hold 100 cards. Do not attempt to insert more than 100 cards. Too many cards may cause the Dispenser to jam or result in other problems.

Insert magnetic cards into the Dispenser in complete packs of 100 or after carefully counting the number of cards (not to exceed 100).

Load cards in the correct orientation.

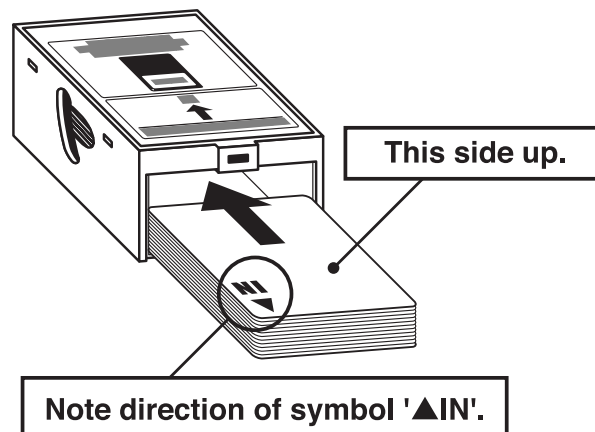

FIG. 7. 1 b

- ⑥ Reinstall the cover to the dispenser.
- ⑦ Insert the dispenser into the card reader/writer. The dispenser can be inserted only in the predetermined orientation.
- ⑧ Close and lock the cover.
- ⑨ Secure with the truss screw



- The unit enters Head Cleaning Mode when any of the following conditions are met:
 - At power-up if the Card Reader/Writer has operated 150 times or more
 - At boot time after performing Backup Data Clear
- Once the unit enters Head Cleaning Mode, follow the on-screen instructions and perform Head Cleaning. The unit will not exit Cleaning Mode (i.e. games may not be played) until head cleaning is complete.
- Always use the designated Cleaning Card. Using anything other than the designated card or carrying out any other procedure other than the one outlined in the manual may cause faulty printing, faulty operation and/or unit failure.
- Cleaning Cards may only be used once. Dispose of them after use.
- Cleaning Cards should be used immediately after removal from the package. Cleaning Cards will not clean effectively if dried out.
- Perform head cleaning only when there are cards in the Card Reader/Writer Dispenser. If the Dispenser is empty, the part that secures the cards inside the Dispenser may touch the rotating part of the Card Reader/Writer and cause noise.
- Always remember to remove the Cleaning Card after completing head cleaning.
- After head cleaning, wait for the "SEGA LOGO" to be displayed at least twice before resuming gameplay.

This machine records the number of times the Card Reader/Writer is used. The Card Reader/Writer writes data to and reads data from cards. Each write and read is counted, so the Card Reader/Writer usage count will not be the same as the number of times the game is played.

Once head cleaning of the Card Reader/Writer is complete, the unit will exit this mode. Follow the on-screen instructions to carry out cleaning.



PHOTO 7. 2

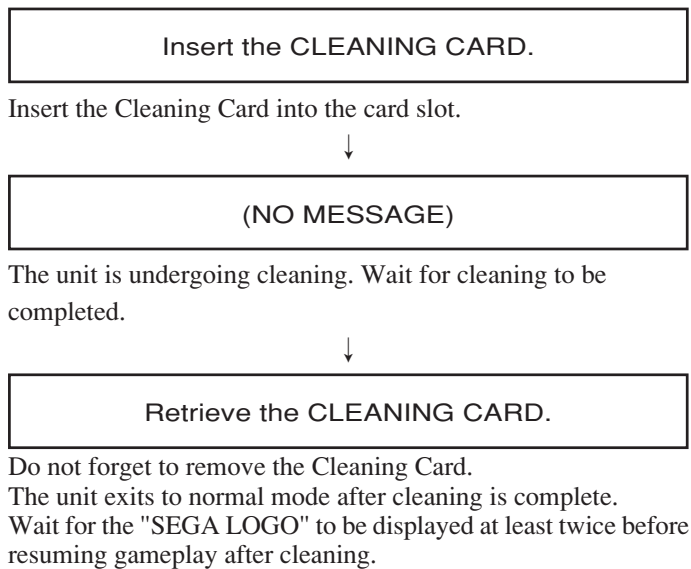

The Card Reader/Writer usage count described above is reset when cleaning is performed.

Manual head cleaning may also be performed from Test Mode. Refer to Test Mode <10-3F> for more details.

7-3 CLEARING CARD JAMS



When attempting to perform this operation without powering down so that gameplay can be restored, exercise extreme caution. Machine parts may move unexpectedly when the power is ON. This may result in fingers being caught or severed and other injuries. Verify the Stay Lock on the top cover before attempting this procedure. If the top cover closes during the procedure, it may result in serious injury.

If a trouble such as card jamming occurs on the card reader/writer, you are notified of the trouble on the screen. You cannot proceed to a play unless you resolve the trouble at this time. First identify the trouble before you begin to take action.

An error message is displayed at the top of the screen when cards become jammed. When not discharging a card, follow the instructions below to remove the card. Removing the card may force the game to shut down. If the game shuts down, existing customer game data will not be saved.

- ① Remove the truss screw.
- ② Unlock and open the cover.



PHOTO 7.3 a

- ③ Unlock the hatch by drawing the green shaft attached to the top cover on the card reader/writer. While drawing the shaft, open the cover up.
- ④ Remove the card jammed in the card reader/writer.

Remove the card jammed.

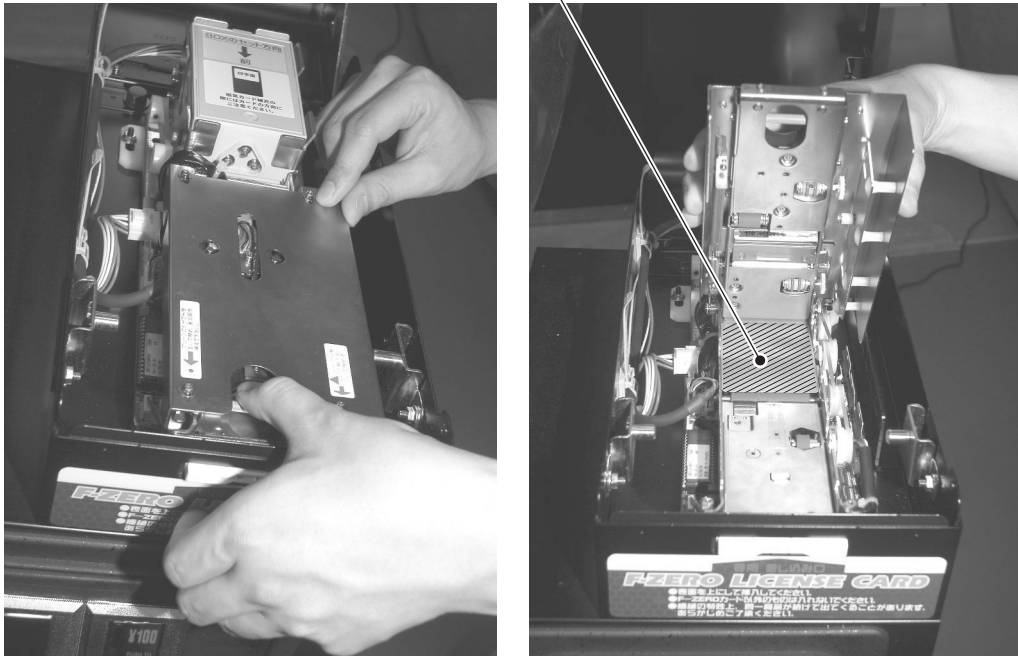

PHOTO 7.3 b

- ⑤ While drawing the shaft, close the cover. With the top cover closed, release the green shaft. Check that the top cover has been locked securely.
- ⑥ Close and lock the cover.
- ⑦ Secure with the truss screw.

8. PRECAUTIONS WHEN MOVING THE MACHINE

8 — 1 MOVING THE MACHINE



- When moving the machine, be sure to pull out the plug from the power supply. Moving the machine with the plug as is inserted can cause the power cord to be damaged and could result in a fire and or electric shock.
- When moving the machine on the floor, retract the Adjusters and ensure that Casters make contact with the floor. During transportation, pay careful attention so that Casters do not tread power cords and earth wires. Damaging the power cords can cause an electric shock and or short circuit.
- When lifting the cabinet, be sure to hold the grip portions or bottom part. Lifting the cabinet by holding other portions can damage parts and installation portions due to the empty weight of the cabinet, and cause personal injury.



- Do not move the product with a GD-ROM disc inside. Remove the GD-ROM disc before moving the product. Failure to observe this instruction may cause the GD-ROM disc and/or GD-ROM drive to be damaged.
- Do not hold or press the plastic parts as indicated by the Figure 8.1. Failure to observe this instruction may break the parts, and eventually the broken pieces may cause a personal injury.
- When transporting the machine by truck or other vehicle, do not attach ropes to any part of the machine other than those indicated in the diagram. Doing so may damage machine parts, and the resulting shards and cracks may cause injury. In addition, use cloth or other soft material to protect parts that come into contact with ropes.

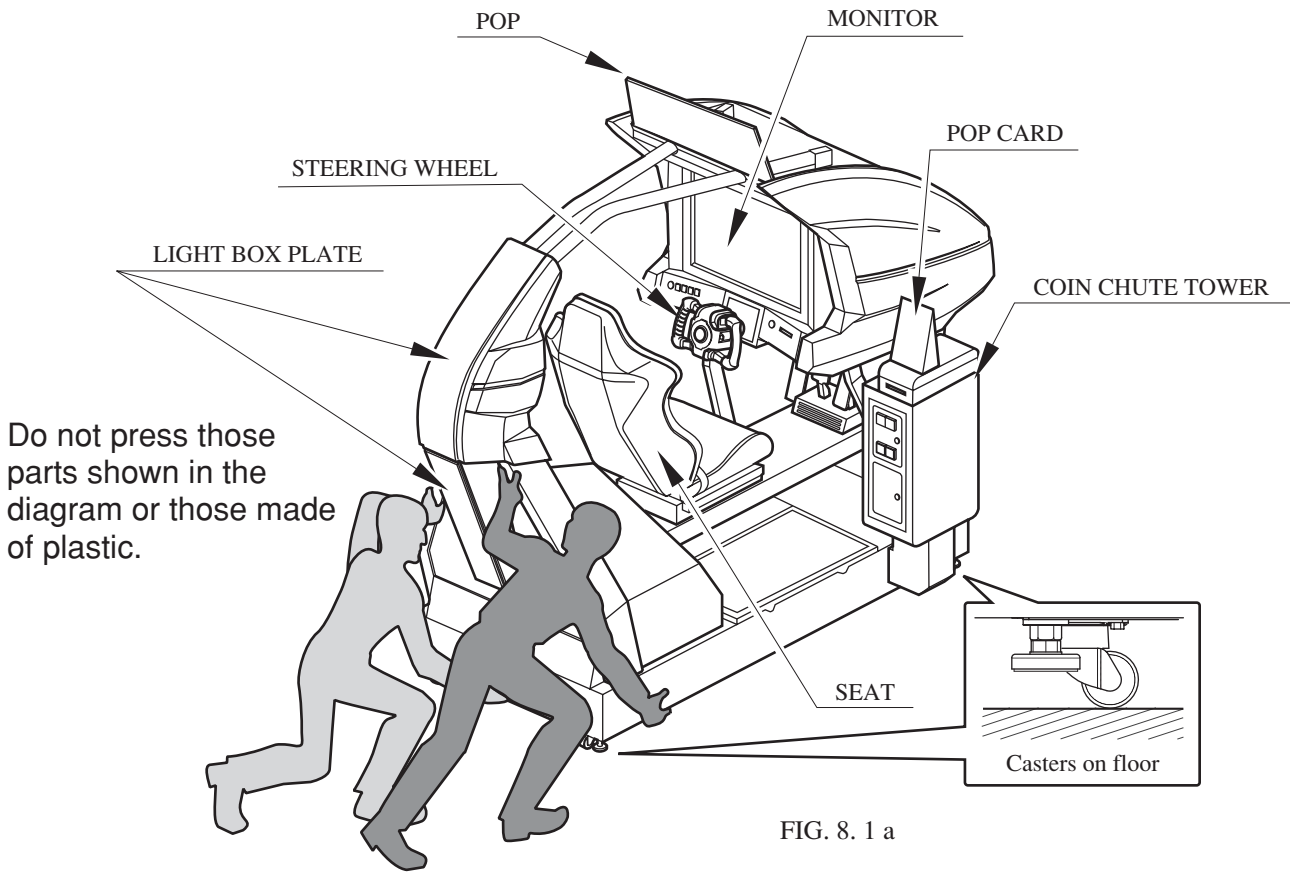

FIG. 8. 1 a

STOP
IMPORTANT

Observe the following precautions when moving the machine. Failure to observe these precautions may result in damage to the casters and/or the flooring.

- The machine should be moved along a level floor.
- Ramps should be used to climb/descend steps 1 cm or greater in height.
- The machine should not be moved any faster than walking speed (about 2 km/h).
- The machine should not be tilted too far to one side or loaded excessively on one side only.

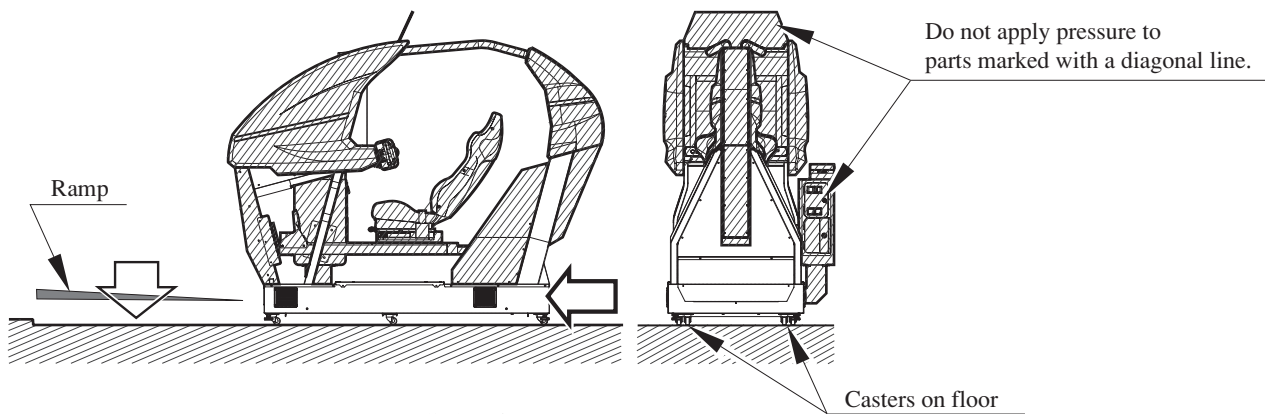

FIG. 8. 1 b

WHEN LOADING ONTO A TRUCK



- A minimum of 8 persons is needed to load this machine onto a forklift truck. The procedure cannot be carried out safely with fewer than this number.
- The forklift should have a platform of at least 1500mm in length. The procedure cannot be carried out safely with a platform shorter than this.
- When using a crane to move this machine, ensure that the person operating the crane is properly qualified. Do not attempt to carry out this procedure without properly qualified personnel.



When placing the machine onto a platform or onto the ground, lower it slowly in an upright, level position. If the machine is lowered at an angle, the weight may be distributed unevenly and damage to casters/adjusters may result.

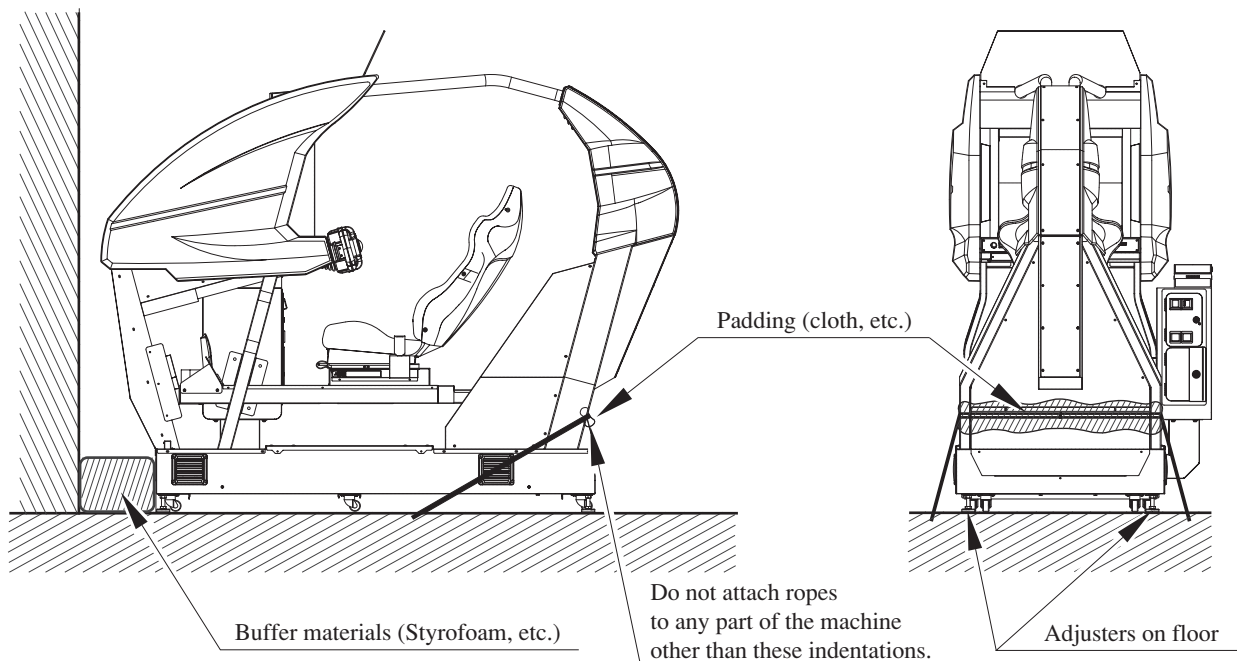

FIG. 8. 1 c



- The following operations should be carried out by the store's maintenance personnel. Serious accidents such as electric shock may result if the operations are carried out by persons lacking the necessary technical knowledge,
- When disassembling the machine in order to move it from one installation location to another, be sure to turn off the power before beginning the operation. Failure to do so may result in electric shock.
- Operations should be performed exactly as they are described in this manual. Accidents may occur if the operations are not performed in the proper manner and order, or if two operations are performed at once. Such actions may also make it impossible to perform subsequent operations and result in damaged or deformed parts.
- Follow the procedures outlined in this manual for safe and accurate installation. Failure to do so may result in accidents during operation.
- If the machine does not fit through the entryway to the installation location, do not disassemble it without first consulting the instructions. The machine should only be disassembled in accordance with the instructions listed in this manual; do not attempt to disassemble it in any other way. Specific tools and adjustment procedures are required to assemble and disassemble its mechanical parts. Attempting to assemble or disassemble the machine without consulting the instructions may result in accidents during assembly/disassembly and electric shock, short circuits, and/or personal injury during operation. If the machine still does not fit through the entryway after following the procedures listed in this manual, contact your retailer or the office listed in this manual.
- If the machine is still too large to fit through the entryway after following the procedures listed in this manual, do not tip the machine on its side. Attempting to transport the machine while it is tipped on its side may cause accidents. It may also damage or warp parts of the machine, resulting in accidents while operating the machine.
- Be sure to have the indicated number of personnel on hand when performing these operations. Attempting to perform an operation with fewer people than indicated may result in injury to personnel. It may also cause secondary accidents such as dropped parts.
- Take care not to damage the wiring. Damaged wiring can cause electric shock and/or short circuits.
- Leave plenty of space to perform these operations. Working in areas where the floor space is too narrow or the ceiling is too low will not only hinder progress, but may also lead to accidents.
- Do not perform these operations on inclined surfaces or surfaces with steps or troughs. Doing so may result in serious accidents (e.g. causing the cabinet to tip over.) Operations are also rendered more difficult by such surfaces.
- Make sure that persons other than the personnel performing the operations are not allowed to enter the work area.
- When placing removed parts aside, take care not to pinch fingers or toes.



- In order to ensure safety and reliability, use a solid, sturdy stepladder when performing these operations. Failure to do so may cause personnel to slip and fall or the machine to tip over.
- Be careful when handling parts made of plastic. Handling these parts carelessly may damage them, and the resulting shards and cracks may injure personnel.
- When securing plastic parts in place, take care not to make the screws and nuts too tight. Doing so may damage these parts, possibly resulting in injury to personnel.



- Use blankets or other soft materials to avoid scratching the surface of removed parts.
- Certain types of floor surfaces may become scratched during disassembly. Check to make sure the floor is of an appropriate type before beginning work.

If the entryway to the installation location is too narrow or low, follow the steps listed below to disassemble the machine.

In the steps listed below, removing the coin chute tower will reduce the machine's width to 1020 mm. Removing the monitor box will reduce its height to 1500 mm.

After disassembling the machine and transporting it through the door, reverse the procedure to reassemble it.

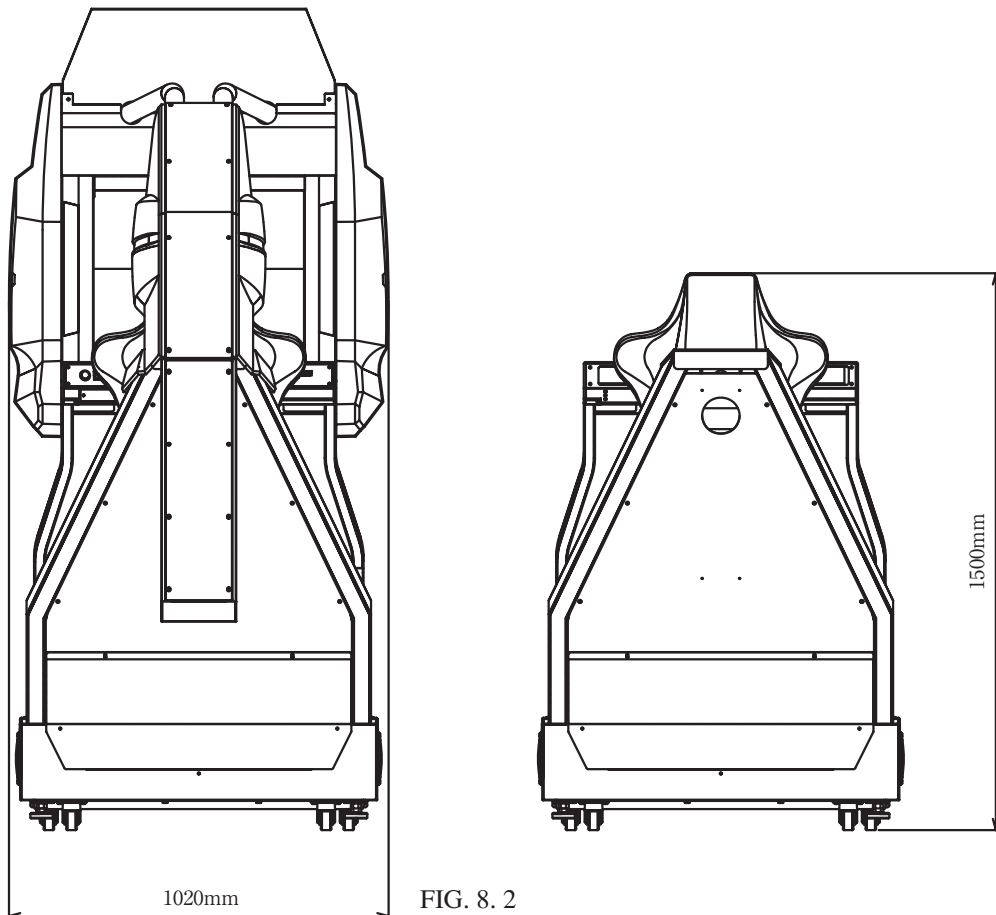

FIG. 8. 2

1

Check the following items to ensure safety.

- Is there enough space to perform the operation?
- Is the work area level? Are there any slopes, steps, or troughs?
- Is the work area closed to all persons except those involved in the procedure?

When disassembling the machine in order to move it from one location to another, perform the operations listed below. Be sure to turn off the power before beginning.

- Detach the POP (see **1** of Section 6)
- Remove the GD-ROM (see **3** of Section 6)
- Detach the power cord and grounding wire (see **4** of Section 6)

2

Remove the coin chute tower.

- ① Unlock and open the coin chute door and the cash box door.
- ② Remove the cash box.

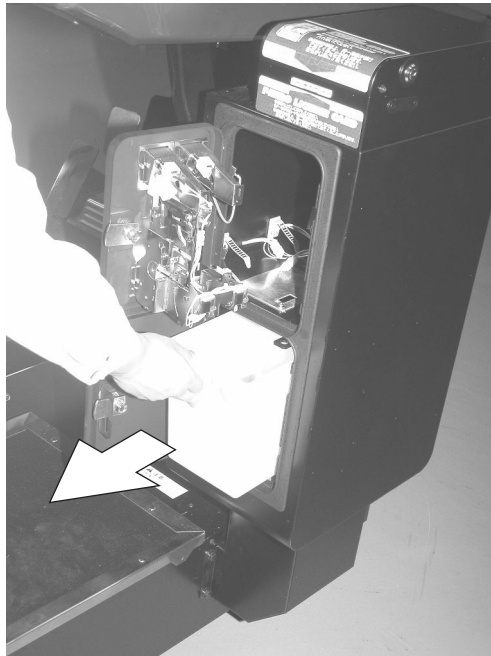

PHOTO 8. 2 a

- ③ There are 3 hexagonal nuts on the base side of the interior of the base box door. Remove the left and right hexagonal nuts, leaving the center nut in place.

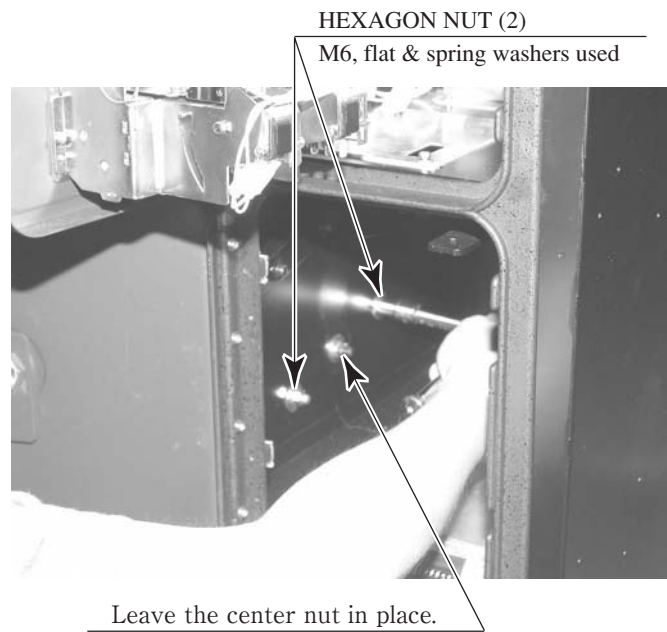
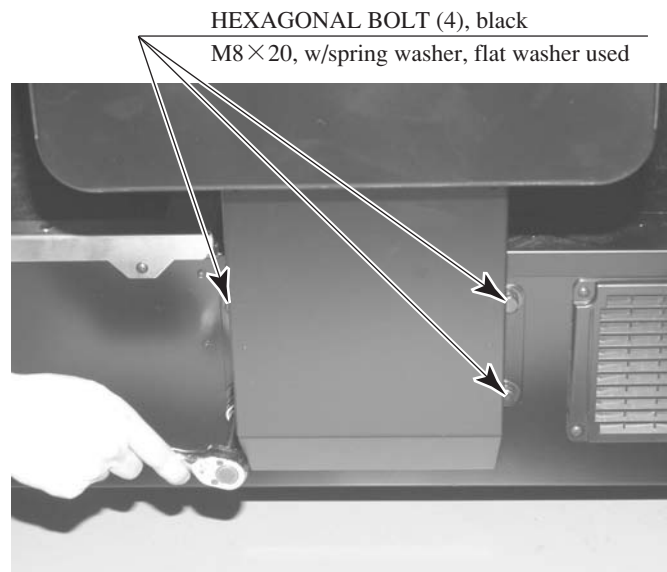

PHOTO 8. 2 b

- ④ Remove the 4 hexagonal bolts on the bottom of the coin chute tower.



- ⑤ Close and lock the coin chute door and the cash box door. Accidents may occur if the doors are accidentally opened or closed.
- ⑥ Spread a blanket or other soft material on the floor to the side of the coin chute tower.

- ⑦ Remove the 6 hexagonal bolts on the pillar side of the coin chute tower. When all 6 bolts have been removed, the coin chute tower will fall over. Have one person support the tower while another removes the bolts.

HEXAGONAL BOLT (2), black
M8×50, w/spring washer, flat washer used

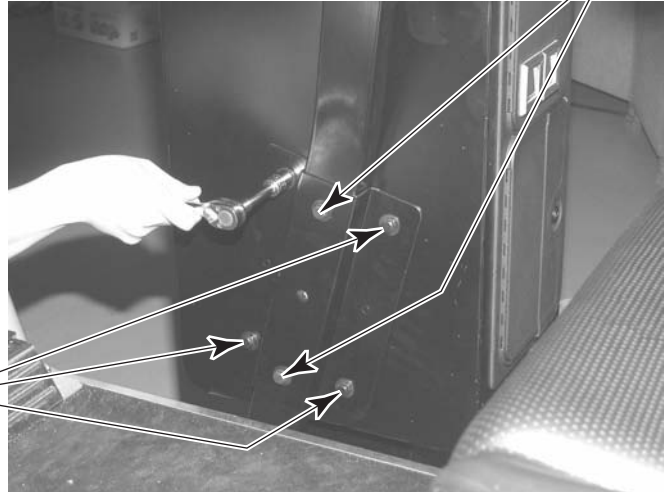

HEXAGONAL BOLT (4), black
M8×20, w/spring washer, flat washer used

PHOTO 8. 2 d

- ⑧ Slowly tilt the coin chute tower and lay it on the blanket. The coin chute tower is connected to the base by wires. Take care not to damage these wires.



PHOTO 8. 2 e

- ⑨ Unplug the 3 wire connectors linking the coin chute tower and the base.

Unplug the connector (3)

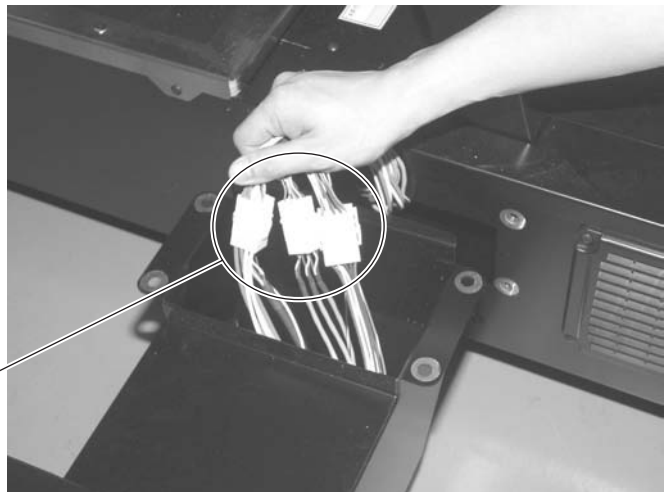

PHOTO 8. 2 f

3

Remove the front side covers from both sides of the monitor box.

- ① Remove the 11 truss screws that are holding the front side cover in place. These screws hold the entire perimeter of the front side cover in place. Make sure that all 11 screws have been removed.

TRUSS SCREW (total 11), black
M4×10, flat washer used

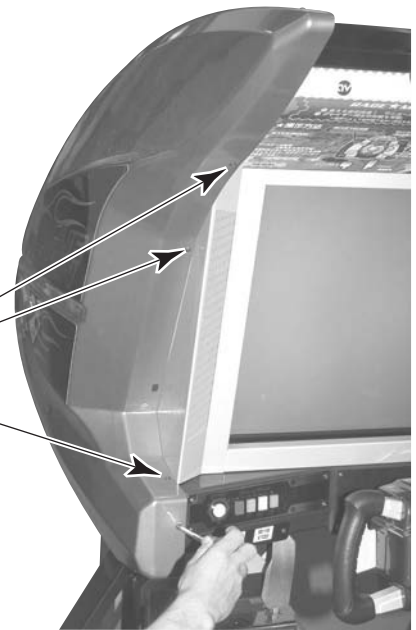

PHOTO 8. 2 g

- ② Remove the front side cover from the monitor box. Removing the cover carelessly may damage it, and the resulting shards may injure personnel.



PHOTO 8. 2 h

- ③ Repeat the above steps to remove the cover on the opposite side.

4

Remove the roof frame and the lower light box.

- ① Remove the 8 truss screws from the upper light box plate and then remove the plate.

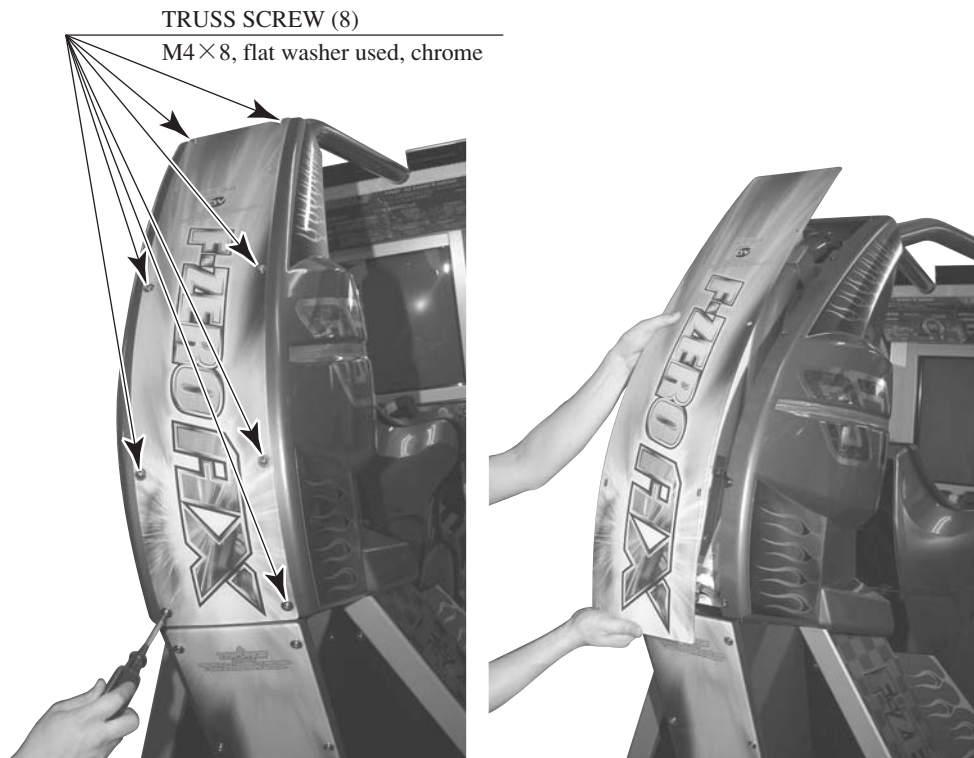

PHOTO 8. 2 i

- ② Remove the 3 truss screws holding the rear side cover in place and then remove the rear side cover. The screws are located on surface of the side of the cover nearest the seat. Repeat the above procedure to remove the rear side cover on the opposite side.

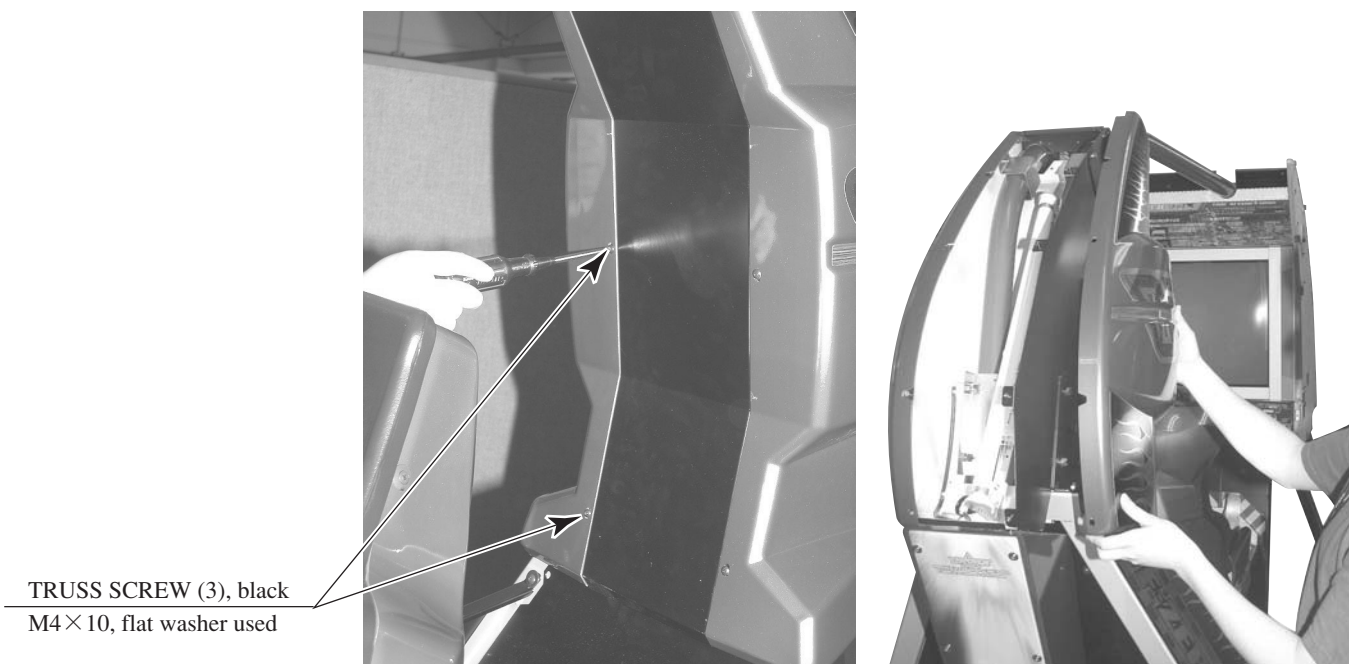

PHOTO 8. 2 j

- ③ Remove the 8 truss screws from the lower light box plate and then remove the plate.

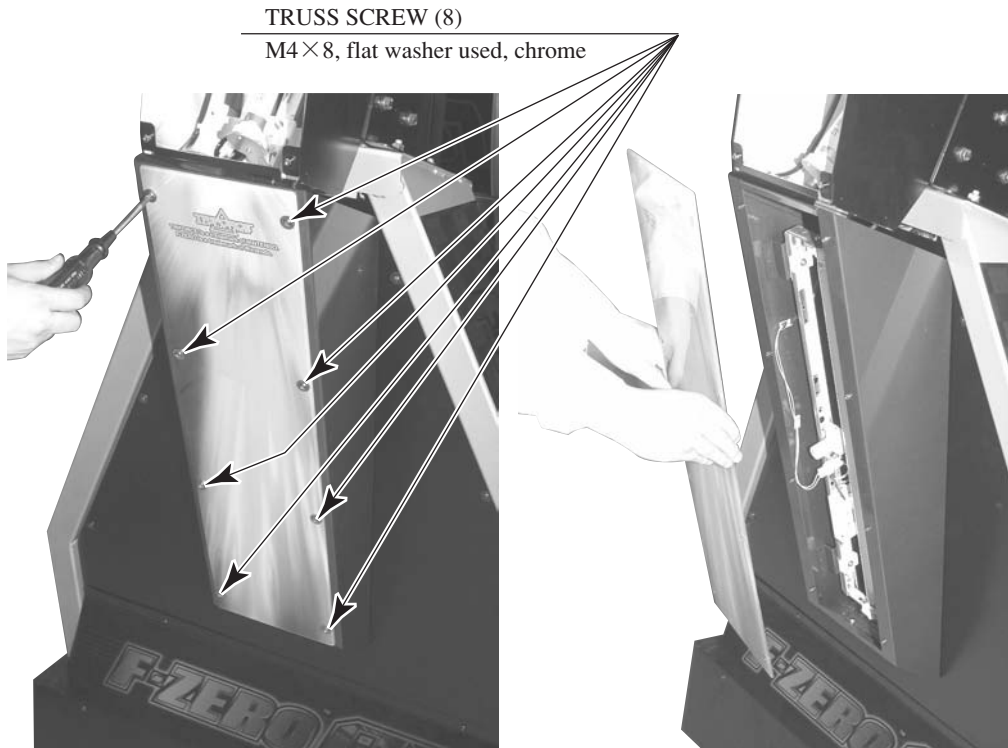

PHOTO 8. 2 k

- ④ There are 2 wire connectors on the inside of the junction point between the roof frame and the lower light box. Pull out the wires and unplug the connectors.

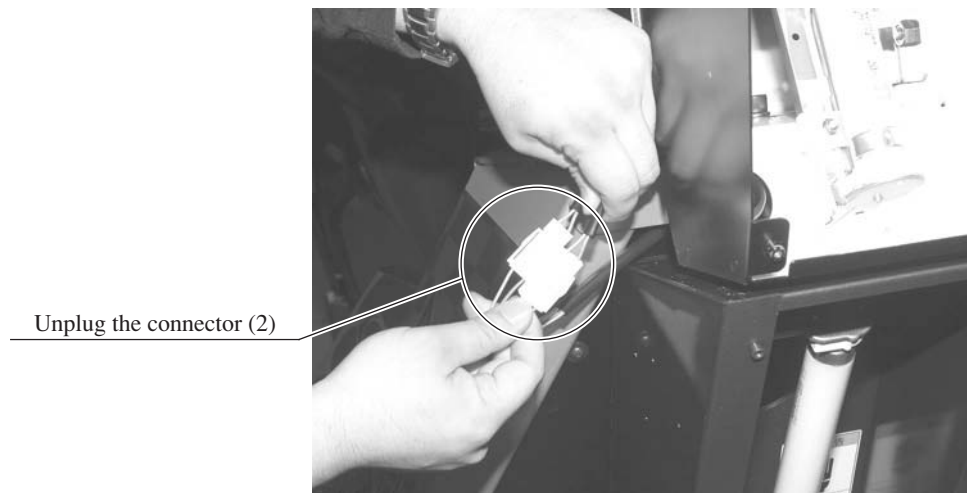
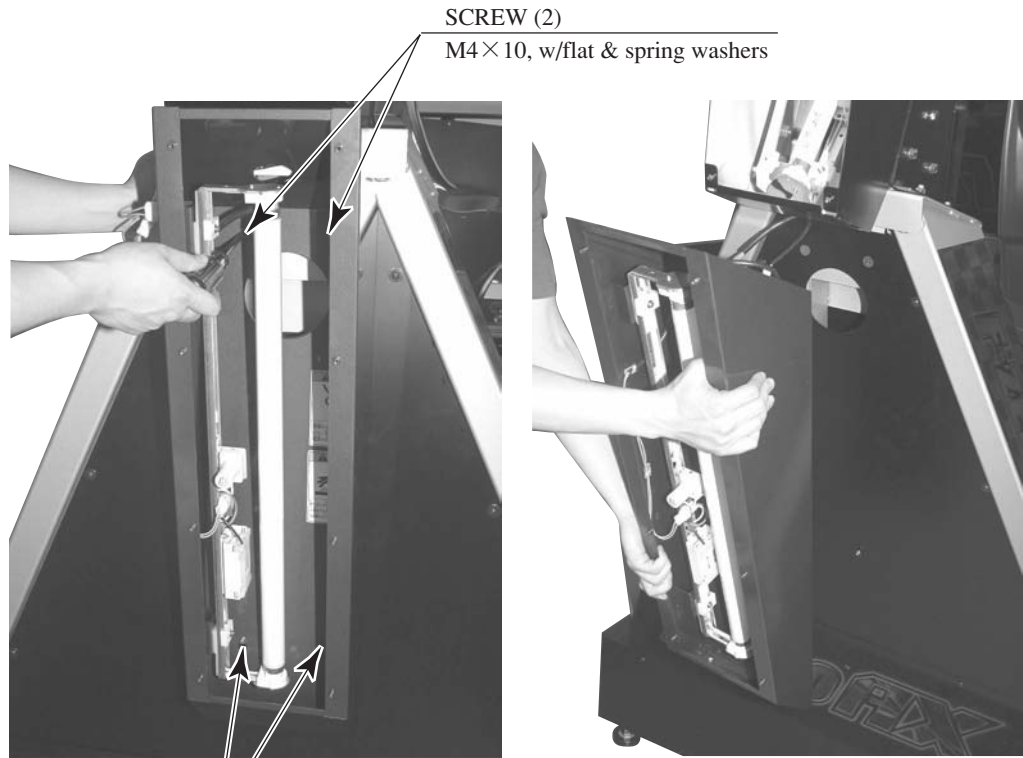

PHOTO 8. 2 l

- ⑤ The lower light box is held in place by 4 screws. Remove the 2 screws on the top side and loosen the 2 screws on the bottom side; this will allow the lower light box to be removed. The fluorescent lamps can easily become broken while removing the screws. Exercise caution while performing this operation.



Loosen the 2 screws on the bottom side.

PHOTO 8. 2 m

- ⑥ Remove the 4 hexagon nuts holding the roof frame in place.

STOP
IMPORTANT

When assembling the cabinet, position the Roof Frame as close to the wall behind as possible before fixing the cabinet in position.

HEXAGON NUT (4)
M8, flat & spring washers used

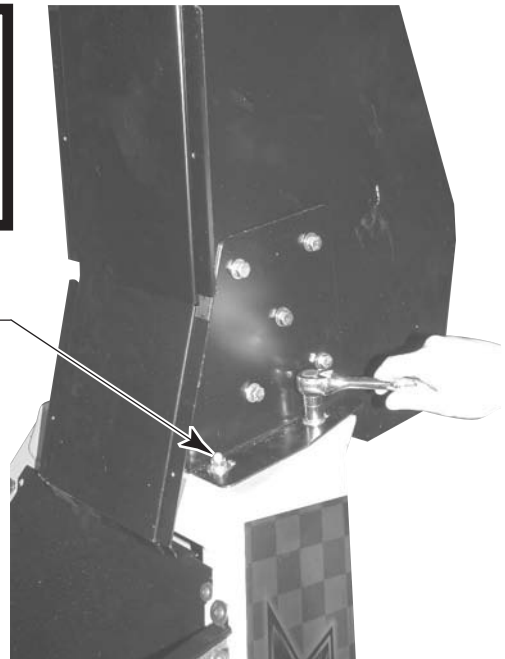

PHOTO 8. 2 n

- ⑦ Remove the 4 hexagonal bolts from the ceiling of the monitor box. A stepladder should be used to perform this operation.

HEXAGONAL BOLT (4), black
M8×50, w/spring washer, flat washer used

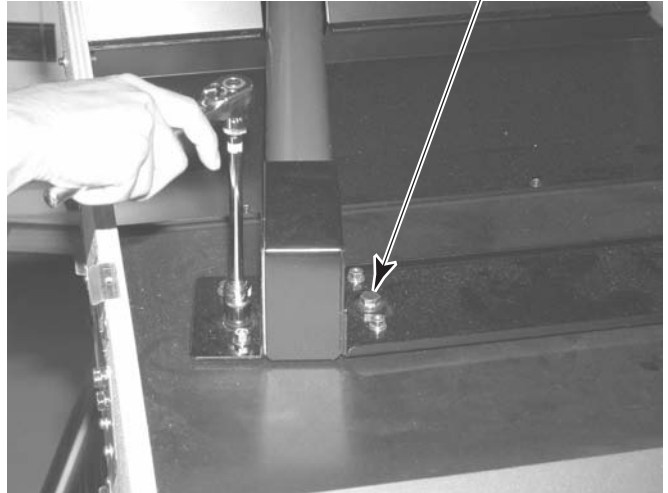

PHOTO 8. 2 o

- ⑧ Working with at least 3 people, pull out the roof frame from above.
- ⑨ When placing the roof frame aside, take care not to pinch fingers or toes.

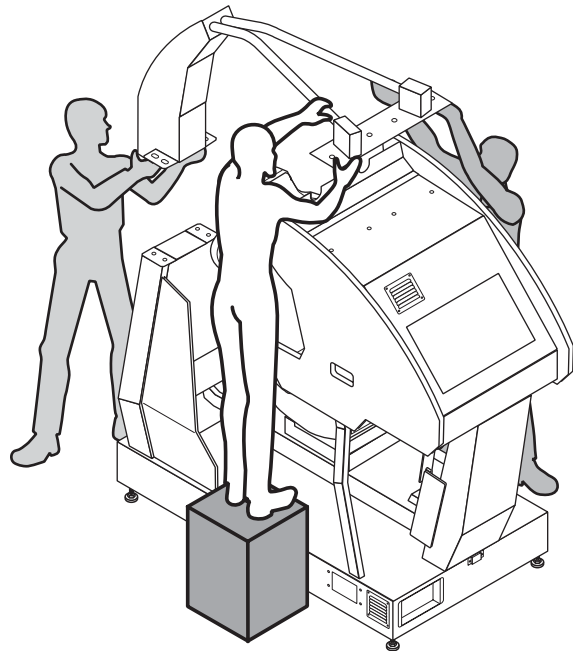

FIG. 8. 2 a

5

Remove the monitor box.

- ① Remove the 2 truss screws from the monitor lid and then remove the lid.

TRUSS SCREW (2), black
M4×25, flat washer used

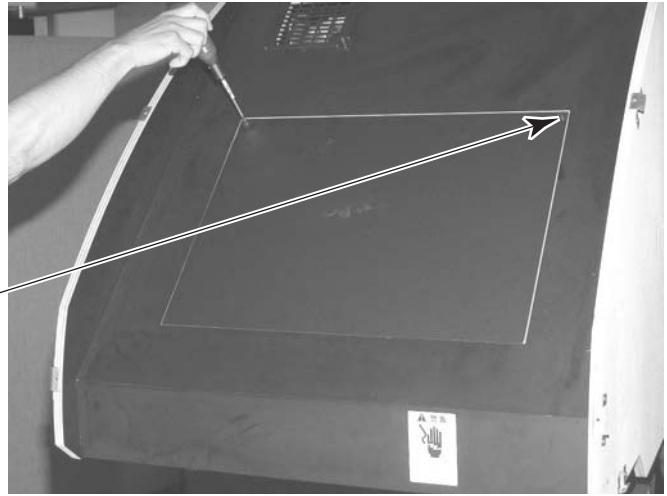

PHOTO 8. 2 p

- ② Unplug all the wire connectors on the inside front of the monitor lid. Facing the lid, there are 7 connectors on the left side and 1 on the right side.

Unplug the connector (1)

Unplug the connector (7)

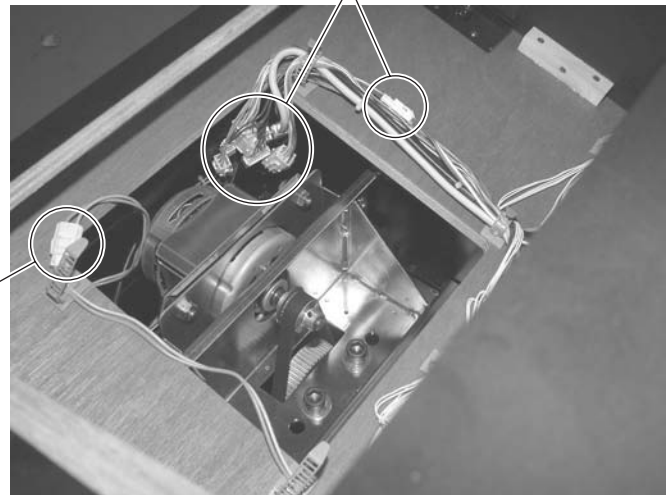

PHOTO 8. 2 q

- ③ Remove the 6 hexagonal bolts from the bottom of the monitor box.

HEXAGONAL BOLT (6), black
M8×80, w/spring washer, flat washer used

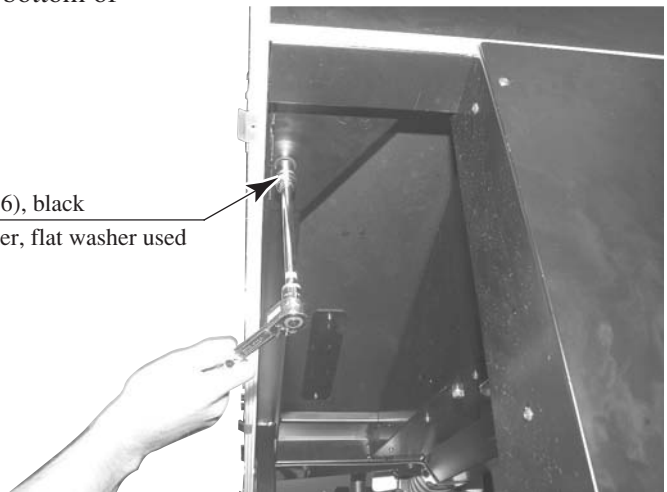

PHOTO 8. 2 r

④ Slowly slide the monitor box about 7 cm forward. Be careful not to slide it too far, as this may damage the wires.

⑤ Unplug the wire connectors from the inside of the control panel. Facing the control panel, there is 1 connector on the left side and 4 on the right side. Unfasten the cord clamp holding the wires in place and pull out the connectors.

Unplug the connector (1)

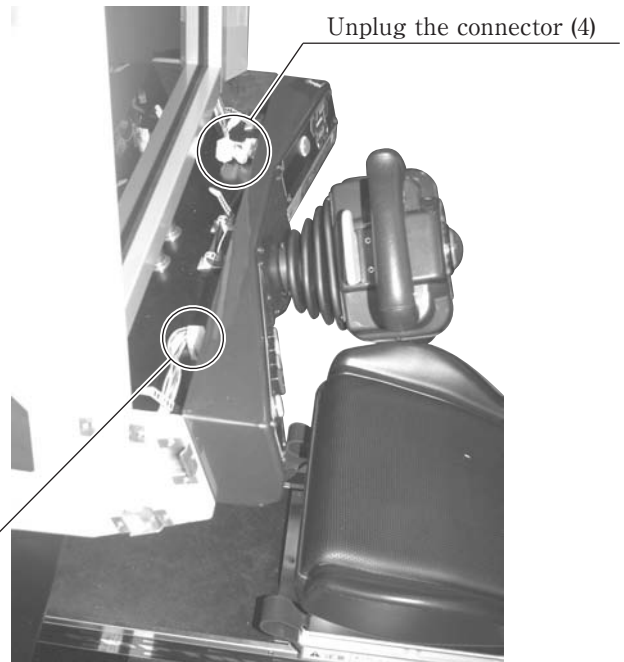

PHOTO 8. 2 s

⑥ Reach through the monitor lid into the control panel and pull the unplugged wire connectors towards the monitor lid.

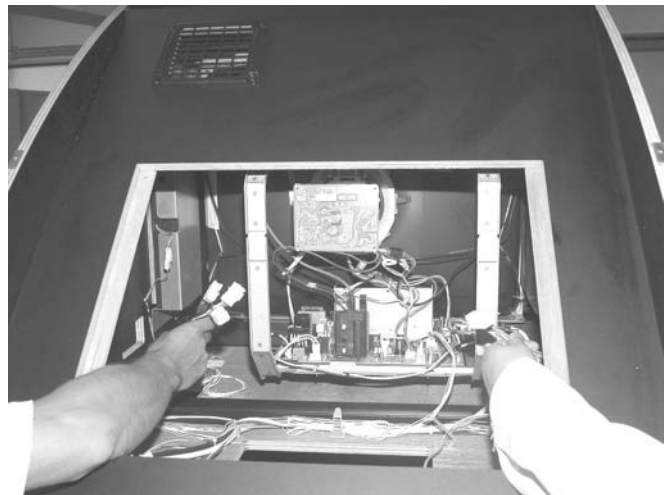
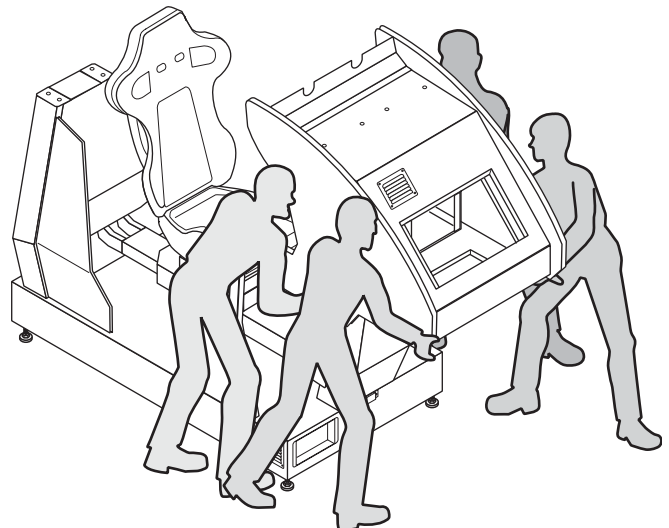

PHOTO 8. 2 t

⑦ With 2 people holding onto each side of the monitor box, slide it forward out of the machine.

⑧ When placing the monitor box aside, take care not to pinch fingers or toes.



9. GAME DESCRIPTION

The following explanations apply to the case the product is functioning satisfactorily. Should there be any moves different from the following contents, some sort of faults may have occurred. Immediately look into the cause of the fault and eliminate the cause thereof to ensure satisfactory operation.

Whenever power is flowing to the machine, the 2 fluorescent lamps on the back side of the cabinet are lit up. While in Advertising mode, the monitor will go through an advertising display loop, explaining the game's content and card system, displaying the rankings, and so on. Sound is output from the speakers to the left and right of the monitor and on the left and right of the seat's headrest. Sound output during Advertising mode can be turned on or off by adjusting the corresponding setting in test mode.

The "Start" button and the 4 "View Change" buttons on top of the control panel are able to light up. They are not lit during Advertising mode.

The "Start" button will blink when enough credits have been inserted to play the game, and cease to blink when it is pressed to start the game. If there are still enough credits to play again after the game ends, the button will begin to blink again. After the race starts, the "View Change" button corresponding to the currently selected view will light up; all the others will remain unlit.

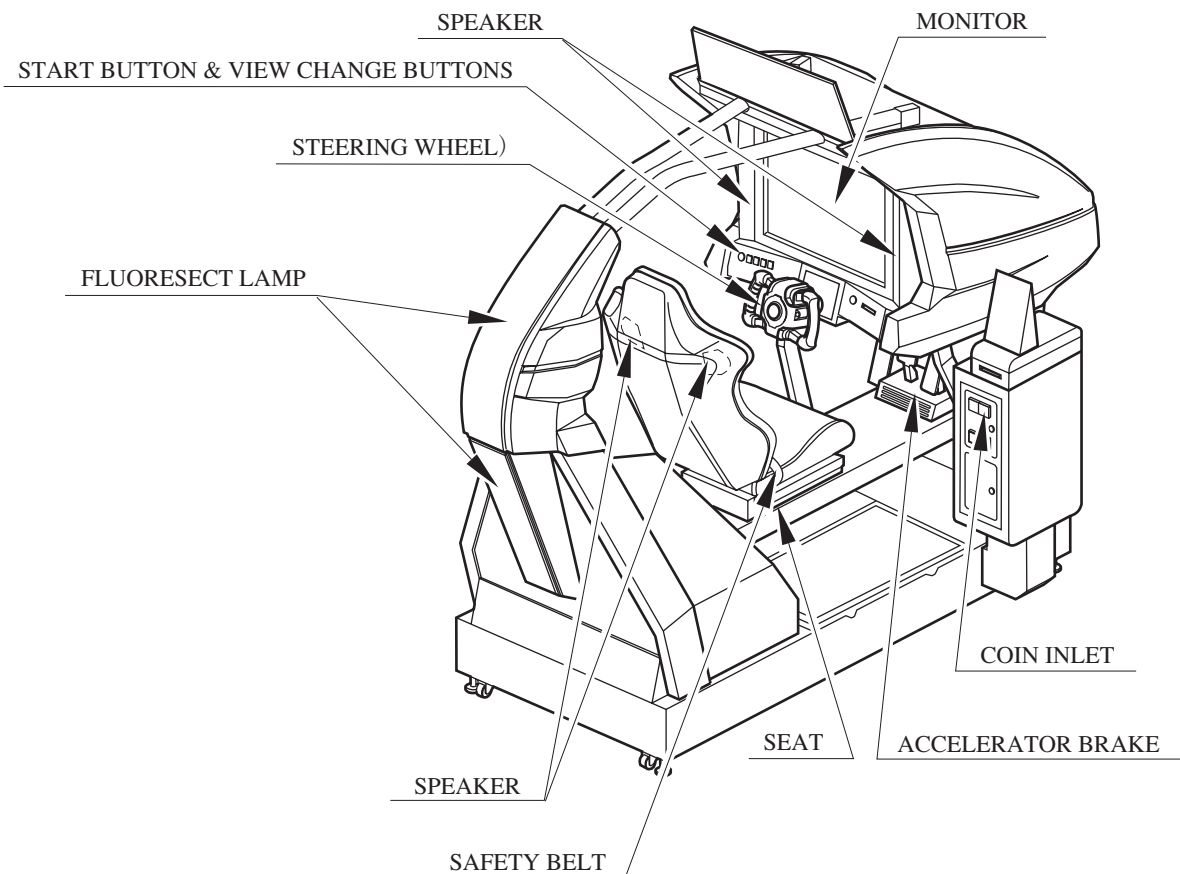

FIG. 9 a

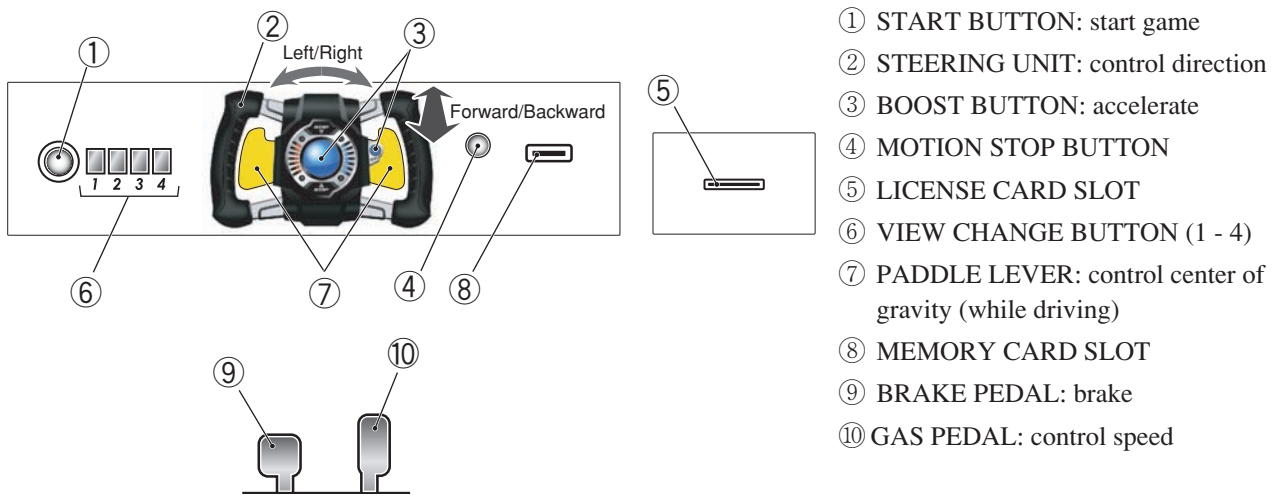

FIG. 9 b CONTROL PANEL

Game Outline

This product is a racing game. It has two modes, RACE MODE and TIME ATTACK MODE. When the cabinets are connected (up to four cabinets), VERSUS PLAY is available. The game features six courses from which the players can choose freely. Each course has a time limit, and if you don't reach the goal within the time limit, your time is up and the race will end. Passing through checkpoints and control lines increases your time. Each course has a different number of checkpoints. A time penalty occurs when the player leaves the course and when his car explodes (energy goes to zero).

● **F-ZERO LICENSE CARD**

You can receive your very own machine by purchasing a license card at the start of play. You can save player data to the card, including your name, pilot rank, pilot points, and time attack records. 1st-place data and numbers of wins are also recorded on the card.

Pilot Points

Use your license card to earn pilot points based on your play in Race and Time Attack Modes. Once you've collected enough points, you can get custom parts to customize your machine with!

Pilot Rank

Your pilot rank increases based on your play. Your rank can never decrease in this game.

● **Nintendo GameCube Memory Card**

Use your Memory Card to link the game with F-ZERO GX for Nintendo GameCube. But in order to use this special feature you must have F-ZERO GX game data on your card, so this feature will not be available until GX is released. Please set Memory Card SLOT USE in Test Mode's GAME ASSIGNMENTS to OUT OF SERVICE or OFF until F-ZERO GX is released. Please note that the game cannot link with a Memory Card that does not contain F-ZERO GX game data.

Game Mode

● Race Mode

A single-course race. Thirty machines go head to head for first place. In linked play, players can go head-to-head against other players.

When using a license card, the game ends when the player takes first place on every course.

● Time Attack Mode

Race a set number of laps in time-trial format and fight for the best total time record. Ghost play is also available.

Internet rankings via PC are also planned. A license card is needed for Internet rankings.

Internet Rankings

Turn **PASSWORD DISP**, found in **GAME ASSIGNMENTS** in Test Mode, to **OFF** until the unit is working properly. (The factory default is **OFF**.)

When **PASSWORD DISP** is set to **OFF**, the Internet Rankings guide is not shown during advertising.

When it is set to **ON**, a password is shown after playing Time Attack. Enter this password with a PC to join the F-ZERO Internet Rankings.

At the start of operation the rankings will be available on the F-ZERO Official Home Page (<http://f-zero.jp/>).

Playing the Game

- (1) The **BEFORE YOU START** Screen
Shows various warnings.

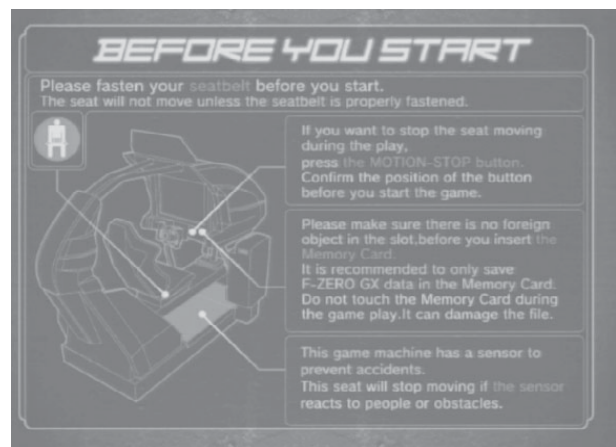

- (2) The Card Check Screen
If you already have a license card, place it in the License Card Slot to continue automatically to the next screen. You can insert the Memory Card in this screen as well, but if you do not insert the Memory Card before the license card, it will not work properly.



(3) The F-ZERO LICENSE CARD Screen

Press down on the accelerator in the Card Check Screen to move to the Purchase Screen. When creating a new card, insert the required number of coins to make a new license card. When your license card's credits have been used up, you will be moved to the Renewing Purchase Screen. You can insert the Memory Card in this screen as well, but if you do not insert the Memory Card before the license card, it will not work properly.

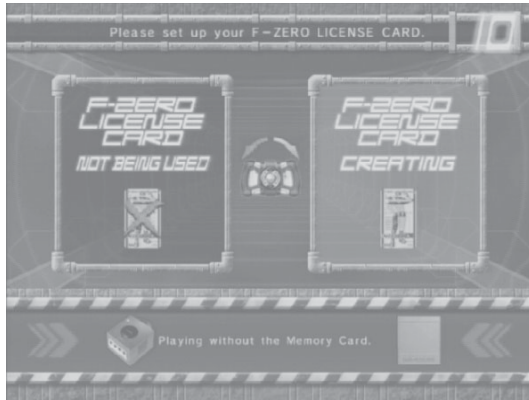

<Creating a new card>



<Renewing>

(4) The NAME ENTRY Screen (Shown the first time a license card is purchased)

When you purchase a new license card, you are moved to the Name Entry Screen. (Inappropriate words will be changed into asterisks.)



(5) The LICENSE CARD Screen

(Not shown if a license card is not used)

Shows your personal car and play information.

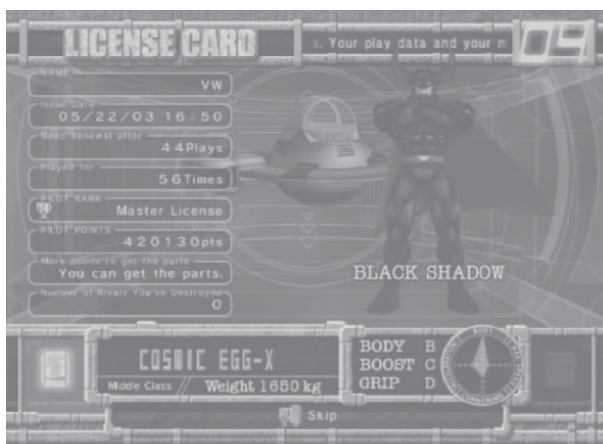

(6) The MODE SELECT Screen

Choose either RACE MODE or TIME ATTACK MODE. Different descriptions will appear below based on the cabinet and Test Mode settings. In Versus Play, select the race mode while holding down the brake to bypass the Versus Screen.



(7) The VERSUS Screen

(When linked and playing Race Mode.)

When you choose Race Mode in the usual way, you will be taken to the Versus Screen. Empty cabinets will display a similar screen.

If you are using a license card, Race Mode-related data will appear. If others are also using license cards, you can take a look at their data. The layout of the screen differs according to the number of linked cabinets (though the information shown is the same).

* You cannot skip this screen.

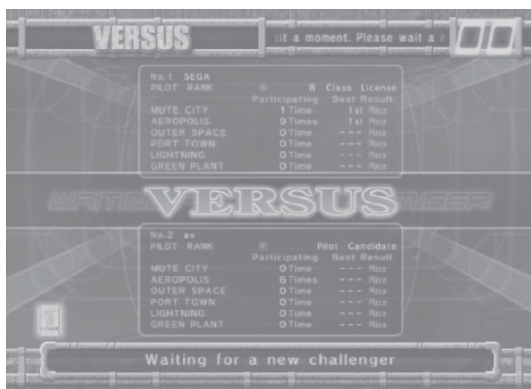

<2 cabinets linked>

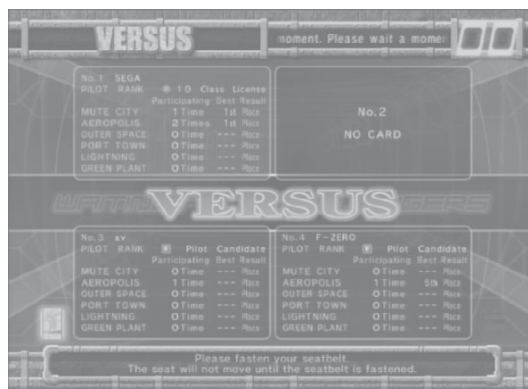

<3-4 Cabinets linked>

(8) The COURSE SELECT Screen

Select your favorite course from the six available. In Time Attack Mode, you can also configure Ghost settings. (Use the pedal lever to choose a ghost.) If you are using a License Card, you can look at information on each course. In Race Mode, wins, win percentage, and other data appear. In Time Attack Mode, total time, best lap, and max speed are shown.



< Race Mode >

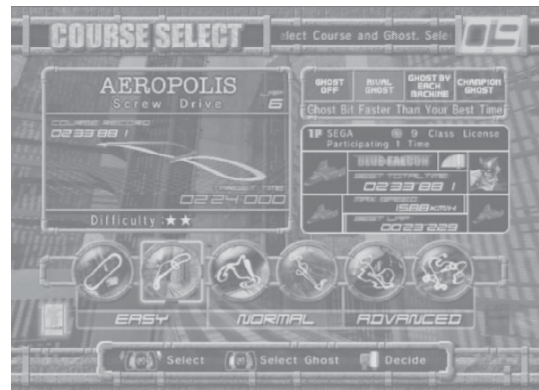

< Time Attack Mode >

(9) The MACHINE SELECT Screen

Select your machine. You always get to choose machines, regardless of your card. The machines you can choose from change based on the card(s) you've inserted.

- No Card: Select from the default 14 machines.
- License Card: Select from 15 machines, including your own on the far left.
- Memory Card: Adds machines from your F-ZERO GX garage on the far right.
If there are no cars in your F-ZERO GX garage, no machines will appear.



(10) The MACHINE SETTING Screen

Use the graph to configure your machine.

In multiplayer Race Mode, you can view other players' machines. If you are using a License Card in Time Attack Mode, you can look at best total times, machines used and settings. If there is no data, NO DATA appears.

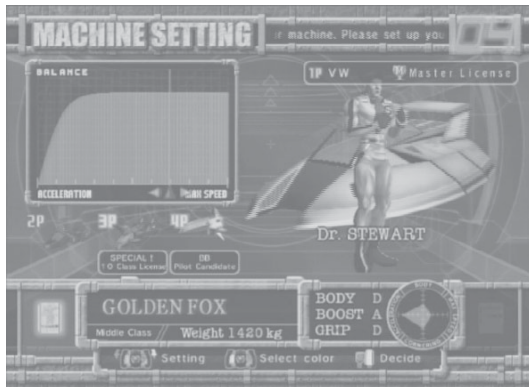

<Race Mode>

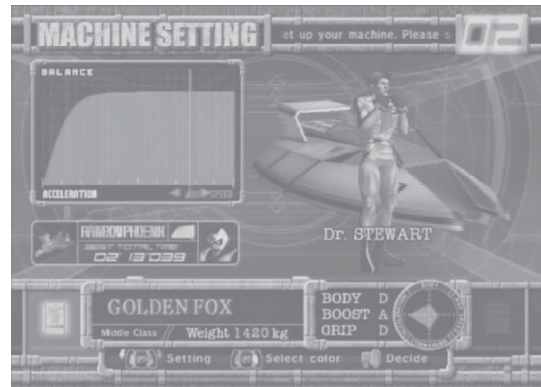

<Time Attack Mode>

(11) Race

This is the racing screen. The basic controls of the machine are the steering wheel and the accelerator. You can use the booster after the second lap, so feel free to press the button in the center of the steering wheel. When the booster is used, the energy drain rate increases. If energy reaches zero and your machine takes damage, your machine will flash red, you will be unable to move, and an official car will come with extra energy. If you leave the course, an official car will come to return your machine to the course.

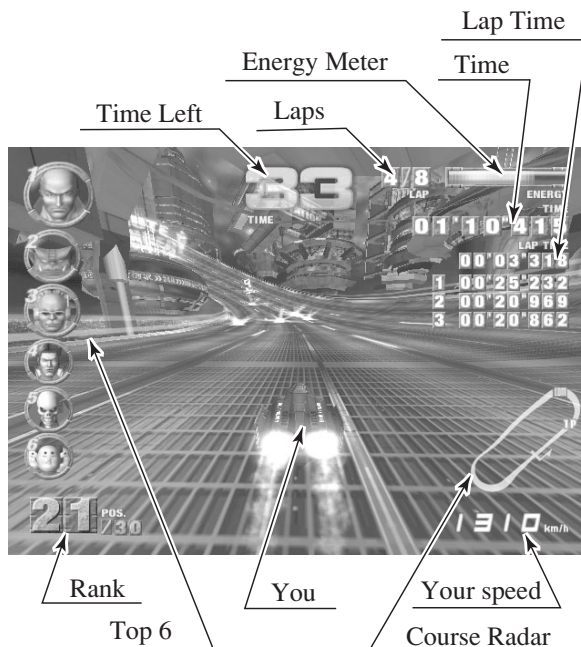

<Race Mode>



<Time Attack Mode>

(12) VS RESULT! Screen

When you complete the race, the results of the race appear. Results do not appear when you retire. The display for COM races and multiplayer races are different in Race Mode. In Time Attack Mode, your personal best and other data are also shown if you use a license card.

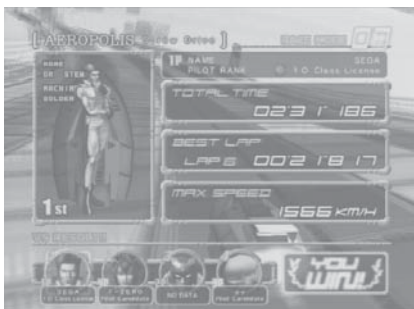

<Race Mode: for COM>

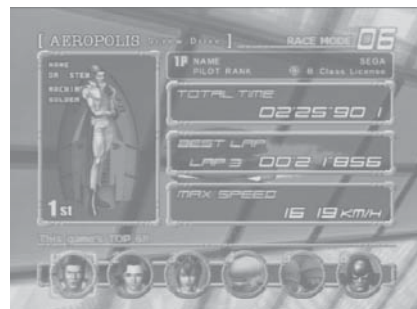

<Race Mode: Multiplayer>

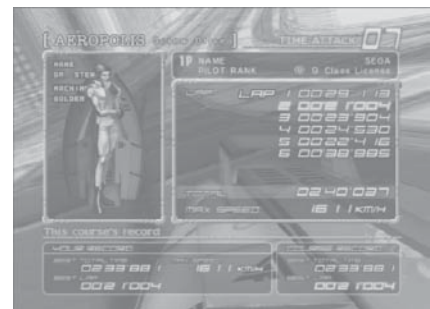

<Time Attack Mode>

(13) RESULTS Screen (Race Mode), TIME ATTACK RANKING Screen (Time Attack Mode)

The Results Screen shows the results of the race, while the Time Attack Ranking Screen shows the best times recorded in the cabinet. When using a License Card, your username is automatically entered. If you are not using a License Card, you can enter a three-letter rankings name.



<Race Mode>



<Time Attack Mode>

(14) The PILOT POINTS Screen

(Only with License Card)

Gives you Pilot Points based on your race performance.

Points are added and totaled for each category.

When your Pilot Points exceed the required value, you are congratulated and moved to the Congratulations Screen. This screen also informs you of Pilot Rank promotions.

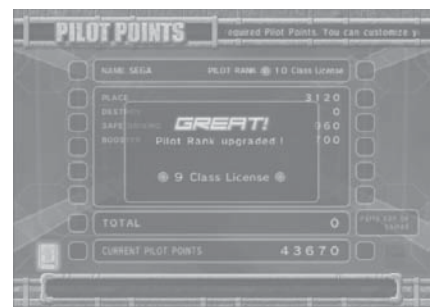
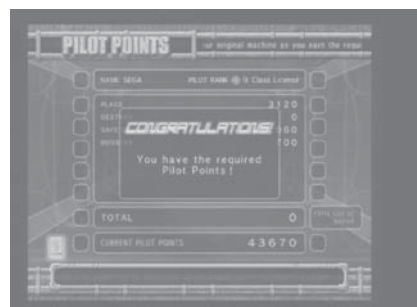

(15) The CONFIGURATION Screen

(Only with a License Card and sufficient Pilot Points)

Lets you switch out your personal machine's parts and change pilots. Changing parts and pilots costs Pilot Points. When you change machine parts, the old parts are disposed of.

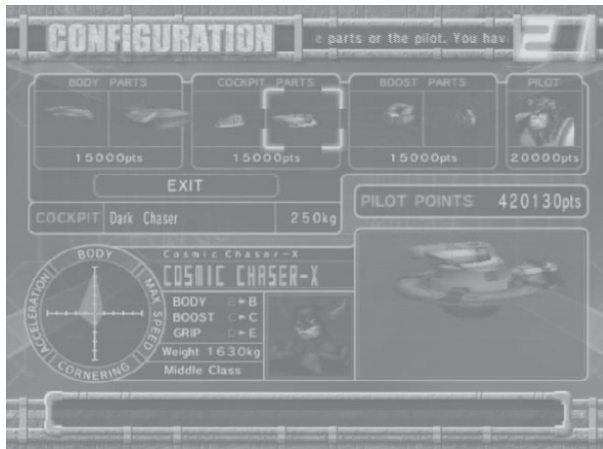

(16) Memory Card Screen

(Only with a Nintendo GameCube Memory Card inserted)

If you play with a Memory Card inserted and satisfy certain conditions, you can download special F-ZERO AX data to your Memory Card. You can then use the downloaded data in F-ZERO GX.

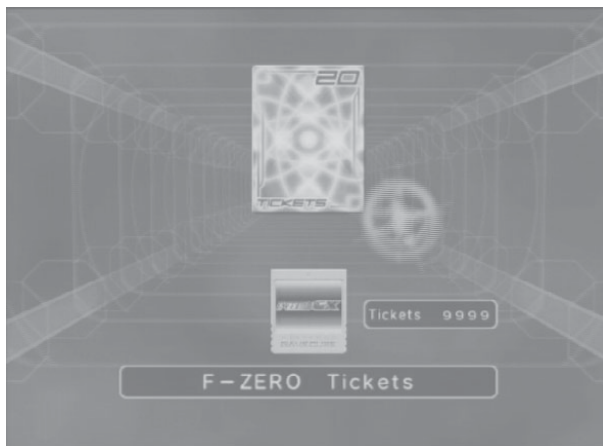

(17) The PASSWORD Screen

(Only with a License Card, when playing Time Attack Mode, and when the course has completed data)

Once you complete a course in Time Attack Mode, you are taken to the Password Screen and given a password. This password is for your best total time. It is shown every time, but it is not necessarily the password for the race.

Enter the ID and name written to your License Card and the password shown on this screen into the F-ZERO Official Home Page to join the Internet Rankings. The launch of the Internet Rankings will be announced on the F-ZERO Official Home Page (<http://f-zero.jp/>).

Set PASSWORD DISP to OFF in GAME ASSIGNMENTS in Test Mode to hide this screen. You cannot continue to the next screen until the License Card is removed.



(18) The GAME OVER Screen

This screen is shown when the game is over. A reminder regarding your card (and seatbelt) is shown.

And if your license card will need to be renewed next time, this screen will indicate that.



Other Warnings

● Error Display

Basic errors related to magnetic cards and memory cards cause detailed instructions to appear on the screen. Mechanical errors in the cabinet, however, are displayed with error numbers. The following is a description of those errors. (See 18-4.)

- Error 01 : Cabinet — I/O Error
- Error 02 : Cabinet — Overheat/Overload Error
- Error 03 : Cabinet — Encoder Error
- Error 04 : Cabinet — Excess Current Error
- Error 05 : Steering — I/O Error
- Error 06 : Steering — Overheat/Overload Error
- Error 07 : Steering — Encoder Error
- Error 08 : Steering — Excess Current Error

● Secret Codes

Race Mode: "No Versus"

- Description: Play by yourself, with no VERSUS screen.
- To access: Hold down the brake when selecting a race mode in the MODE SELECT screen. This is explained in the MODE SELECT Screen help.

Note: No Versus cannot be used when there is only one cabinet.

Race Mode: "VS BATTLE" (Human-only race)

- Description: A race with only human competitors. COM machines cannot join the race. For two to four players.
- To access: Each participant must hold down the brake when selecting their machine in the MACHINE SELECT screen.

Note: Cannot be used with only one cabinet or in one-player play. COM machines will always join.

Race Mode: "No Handicap"

- Description: In Race Mode, cars in the rear are given supplemental speed and can go faster (player-controlled machines only). To turn off supplemental speed, use No Handicap.
- To access: All players (even in one-player races) must hold down the brake when selecting a machine from the Machine Settings Screen.

Note: In Race Mode, even one-player games are handicapped, so use the above to turn handicapping OFF.

Time Attack: Racing Staff Ghosts

- Description: Lets you race against Staff Ghosts
- To access: Hold down the brake with the cursor on "Champion Ghost" in the Course Selection Screen and select a course.

10. TEST AND DATA DISPLAY



Do not touch the machine until it has completed the initialization process and the advertising screen has appeared. Doing so may cause the person touching the machine to be struck by the seat. It may also prevent the machine from initializing properly. Failure to initialize properly can lead to control malfunction and other problems.

By operating the switch unit, periodically perform the tests and data check. When installing the machine initially or collecting cash, or when the machine does not function correctly, perform checking in accordance with the explanations given in this section.

The following shows tests and modes that should be utilized as applicable.

This product's basic system consists of the TRIFORCE game board and the GD-ROM drive.

The product supports, therefore, the following 2 test modes:

- (1) System test mode for an automatic self-diagnostic test (generally used by every product that contains the basic system) and a coin assignment (specifically used by this product) and
- (2) Game test mode for testing the input/output control devices and setting the difficulty level (specifically used by this product).

TABLE 10 EXPLANATION OF TEST MODE

ITEMS	DESCRIPTION	REFERENCE SECTIONS
INSTALLATION OF MACHINE	When the machine is installed, perform the following: 1. Check to ensure each is the standard setting at shipment. 2. Check each Input equipment in the INPUT TEST mode. 3. Check each Output equipment in the OUTPUT TEST mode. 4. Test on-IC-Board IC's in the SELF-TEST mode.	10-3D 10-2E, 10-3B 10-2F, 10-3C 10-2B, C, D
MEMORY TEST	This test is automatically executed by selecting MEDIA BOARD TEST, or SYSTEM INFORMATION in the Menu mode.	10-2B, C, D
PERIODIC SERVICING	Periodically perform the following: 1. MEMORY TEST 2. Ascertain each setting. 3. To test each Input equipment in the INPUT TEST mode. 4. To test each Output equipment in the OUTPUT TEST mode.	10-2B, C, D 10-2H, 10-3D, E, F 10-2E, 10-3B 10-2F, 10-3C
CONTROL SYSTEM	1. To check each Input equipment in the INPUT TEST mode. 2. Adjust or replace each Input equipment. 3. If the problem still remains unsolved, check each equipment's mechanism movements.	10-2E, 10-3B 10-3G 11, 12, 13
MONITOR	In the Monitor Adjustment mode, check to see if Monitor (Projector) adjustments are appropriate.	10-2G 15
IC BOARD	MEMORY TEST	10-2B, C, D
DATA CHECK	Check such data as game play time and histogram to adjust the difficulty level, etc.	10-3H, I



Never touch places other than those specified. Touching places not specified can cause electric shock and short circuit accidents.



- Adjust the sound to the optimum volume, taking into consideration the environmental requirements of the installation location.
- Removing the Coin Meter circuitry renders the game inoperable.

SWITCH UNIT

Open the coin chute door, and the switch unit shown will appear.
The functioning of each SW is as follows:

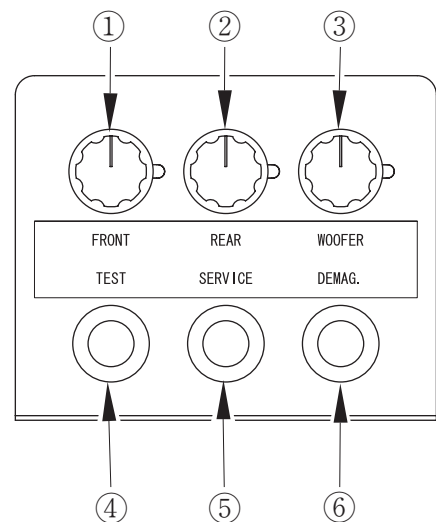

FIG. 10. 1 a SWITCH UNIT

- | | |
|---|---|
| <p>① VOLUME CONTROL:
(FRONT)</p> <p>② VOLUME CONTROL:
(REAR)</p> <p>③ WOOFER CONTROL:
(WOOFER)</p> <p>④ TEST BUTTON:
(TEST)</p> <p>⑤ SERVICE BUTTON:
(SERVICE)</p> <p>⑥ DEMAGNETIZER SWITCH:
(DEMAG.)</p> | <p>Adjusts the volume of the speakers on the left and right sides of the monitor.</p> <p>Adjusts the volume of the speakers on the left and right of the seat headrest.</p> <p>Adjusts the volume of the woofer output inside the base.</p> <p>For the handling of the test button, refer to the following pages.</p> <p>Gives credits without registering on the coin meter.</p> <p>Eliminates the on-screen color unevenness due to magnetization of CRT. First use this SW before performing the monitor's color adjustment.</p> |
|---|---|

COIN METER

Open the Cashbox Door by using the key to have the Coin Meter appear underneath the Cashbox.

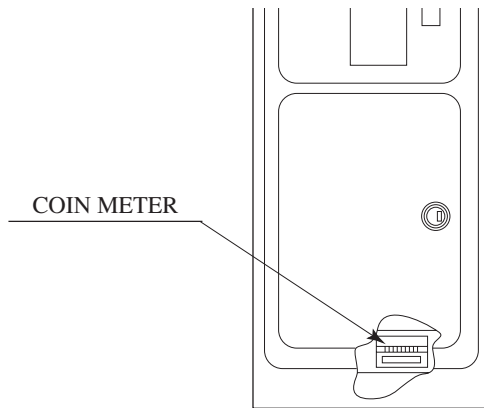

FIG. 10. 1 b



- Any settings that are changed by users during TEST MODE are saved upon exiting TEST MODE with the EXIT command in the SYSTEM MENU. If the unit is powered off prior to exiting, changes to settings will not take effect.
- You may not enter GAME TEST MODE while the unit is reading from or checking the GD-ROM. If error messages are displayed when exiting TEST MODE, you should power the unit off and on again.

The following settings should be set as indicated for this product.

- COIN CHUTE TYPE : COMMON
- SERVICE TYPE : COMMON
- NETWORK TYPE : ETHER

10 – 2A SYSTEM TEST MENU

SYSTEM TEST MODE is used primarily to check if boards are functioning properly, to adjust monitor colours and change coin/credit settings.

- ① Press the TEST Button after powering on the unit to display the following SYSTEM MENU.

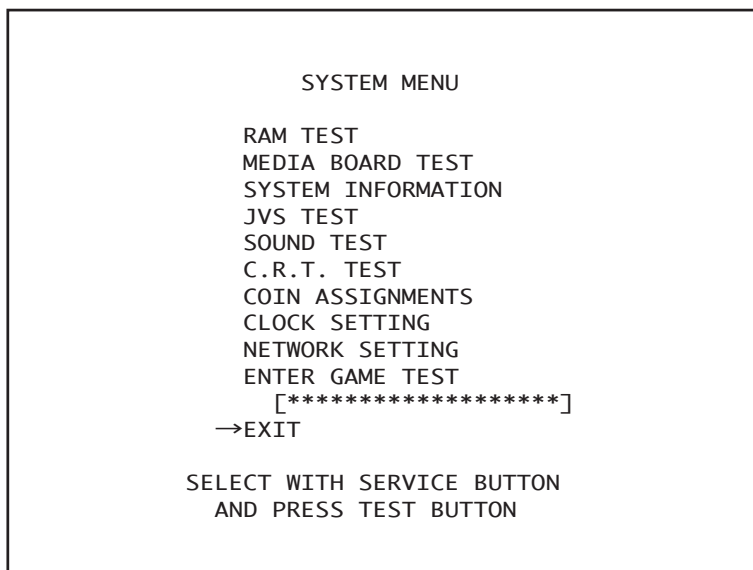

- ② Press the SERVICE Button to move the cursor to the desired test item.
- ③ Move the cursor to the desired item and press the TEST Button to display each test screen.
- ④ Move the cursor to ENTER GAME TEST and press the TEST Button to enter the individual test menus for each game. Refer to "10-3 GAME TEST MODE".
- ⑤ When testing is complete, move the cursor to EXIT and press the TEST Button. The game advertisement screen should be displayed.

10 — 2B RAM TEST

Use RAM TEST to run a check of the TRIFORCE MAIN BOARD memory IC.

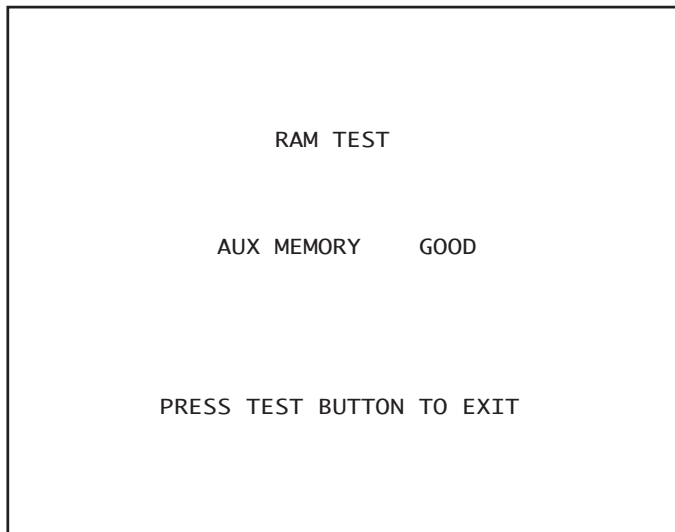

- ① RAM TEST begins immediately upon entering this test mode.
- ② If "GOOD" is displayed at the right-hand side of the screen, memory IC is functioning properly.
- ③ After the test is complete, move the cursor to EXIT and press the TEST Button to return to the SYSTEM MENU screen.



Powering off the system during the MEDIA BOARD TEST with a DIMM BOARD will erase the game programme data. It may be necessary to reload the data.
Always wait for the test to complete before attempting to exit.

MEDIA BOARD TEST is used to check the memory and IC on the MEDIA BOARD connected to the TRIFORCE. Test screens and test times may differ depending on the type of MEDIA BOARD connected to the unit.

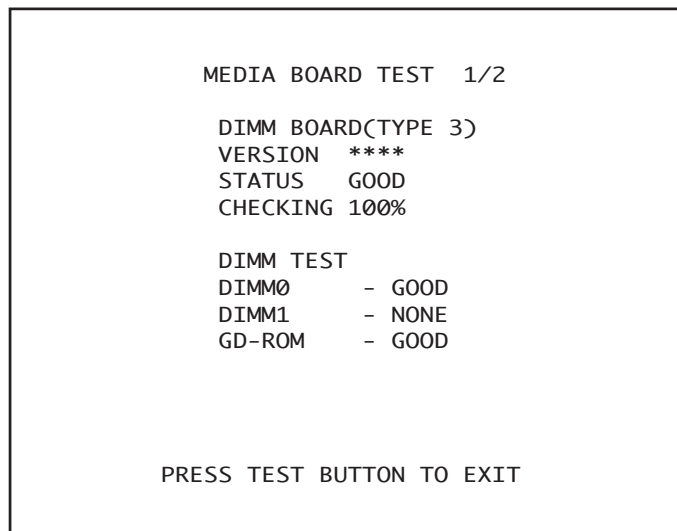

FIG 10. 2 c a MEDIA BOARD TEST Screen (1/2)

- ① MEDIA BOARD TEST begins immediately upon entering this test mode.
- ② If "GOOD" is displayed to the right of each item, the MEDIA BOARD components are functioning properly.
- ③ Press the TEST Button to move to Screen 2/2.
- ④ Press the TEST Button on Screen 2/2 to return to the System Menu screen.

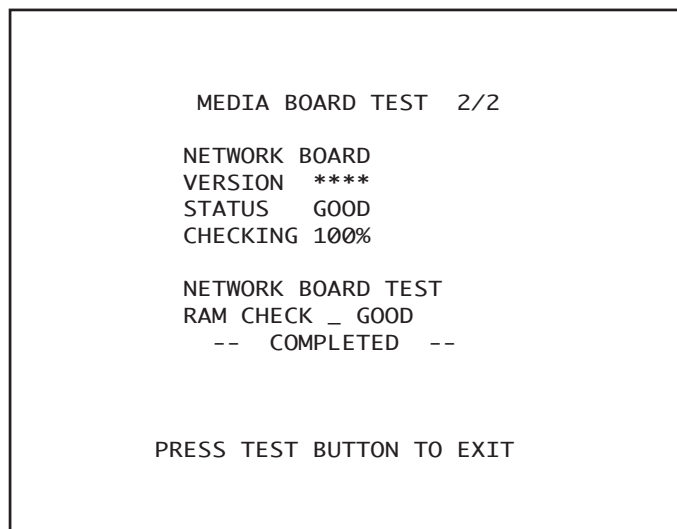

FIG 10. 2 c a MEDIA BOARD TEST Screen (1/2)

10 — 2D SYSTEM INFORMATION

Use SYSTEM INFORMATION to check version and other information for system programmes.

Screens may differ depending on the type of MEDIA BOARD connected to the unit.

SYSTEM INFORMATION		
MAIN BOARD		
REGION	****	(A)
BOOT VERSION	****	(B)
FIRM VERSION	****	(B)
FPGA VERSION	****	(B)
SERIAL NO.	*****	(C)
MEDIA BOARD		
DIMM BOARD(TYPE 3) + GDROM		(D)
MEMORY SIZE	512MB	(E)
FIRM VERSION	****	(F)
SERIAL NO.	*****	(G)
NETWORK BOARD		
FIRM VERSION	*****	(F)
PRESS TEST BUTTON TO EXIT		

Press the TEST Button to return to the SYSTEM MENU screen.

- (A) REGION
The COUNTRY CODE of the MAIN BOARD.
- (B) BOOT VERSION, FIRM VERSION, FPGA VERSION
Version information for the MAIN BOARD system programmes.
- (C) SERIAL NO.
Serial number of the MAIN BOARD.
- (D) DIMM BOARD + GDROM
Type of MEDIA BOARD. This example shows a DIMM BOARD (TYPE 3) with a GD-ROM DRIVE connected.
- (E) MEMORY SIZE
Capacity of DIMM memory installed on the DIMM BOARD.
- (F) FIRM VERSION
Version information for the DIMM BOARD system programme.
- (G) SERIAL NO.
Serial number of the DIMM BOARD.

10 — 2E JVS TEST

JVS TEST is used to verify the specs of the I/O BOARD connected to the TRIFORCE and to run input tests.
I/O BOARD specs are displayed initially.

```

                JVS TEST
                INPUT TEST
                NEXT NODE
                →EXIT
NODE           1/1
NAME          *****
              I/O BD JVS
              *****
              Ver****
CMD VER       1.1
JVS VER       2.0
COM VER       1.0
SWITCH        2 PLAYER(S)  12 BITS
COIN          2 SLOT
ANALOG        8 CH
ROTARY        0 CH
KEYCODE       0
SCREEN        X:0 Y:0 CH:0
CARD          0 SLOT
HOPPER OUT    0 CH
DRIVER OUT    22 CH
ANALOG OUT    0 CH
CHARACTER     CHARA:0 LINE:0
BACKUP        0
              SELECT WITH SERVICE BUTTON
              AND PRESS TEST BUTTON
```

- ① Use the SERVICE Button to move the cursor to the desired test item.
- ② Move the cursor to INPUT TEST and press the TEST Button to enter the INPUT TEST screen for the I/O BOARD currently displayed.
- ③ When 2 or more I/O BOARDS are connected, move the cursor to NEXT NODE and press the TEST Button to enter the test screen for the next I/O BOARD. The lower the NODE number, the further away the node is from the TRIFORCE.
- ④ Move the cursor to EXIT and press the TEST Button to return to the SYSTEM MENU screen.

INPUT TEST Screen

JVS TEST		
INPUT TEST		
NODE	1/1	
SYSTEM	00	(A)
PLAYER 1	0000	(A)
PLAYER 2	0000	(A)
COIN 1	0000	(B)
COIN 2	0000	(B)
ANALOG 1	0000	(C)
ANALOG 2	0000	(C)
ANALOG 3	0000	(C)
ANALOG 4	0000	(C)
ANALOG 5	0000	(C)
ANALOG 6	0000	(C)
ANALOG 7	0000	(C)
ANALOG 8	0000	(C)

PRESS TEST AND SERVICE BUTTON TO EXIT

- ⑤ On-screen values change according to the input from switches and the volume.
- (A) SYSTEM, PLAYER
Values change with input from control panel/other switches.
 - (B) COIN
Increases with input from the COIN SWITCH. The count is cleared when exiting TEST MODE.
 - (C) ANALOG
Displays analog values from "0000" to "FF00".
- ⑥ Press the SERVICE and TEST Buttons simultaneously to return to the JVS TEST main screen.

10 — 2F SOUND TEST

Use SOUND TEST to test sound output and to toggle the stereo/mono setting.

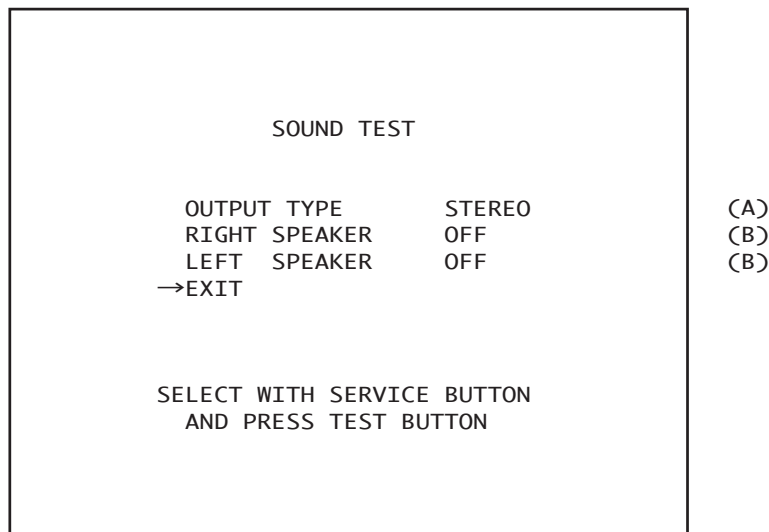

- ① Use the SERVICE Button to move the cursor to the desired test item.
- ② Press the TEST Button to enter the selected item.
 - (A) OUTPUT TYPE (STEREO, MONO)
Toggle the sound output from the I/O PANEL audio output interface setting between STEREO and MONO.
Set to STEREO in this game machine.
 - (B) RIGHT/LEFT SPEAKER (ON, OFF)
When set to "ON", the test sends a beep to each right and left audio output interface. Only the word "SPEAKER" is displayed when the OUTPUT TYPE is set to "MONO", and when set to "ON", the test sends the same beep to both the left/right audio output interfaces.
- ③ Move the cursor to EXIT and press the TEST Button to return to the SYSTEM MENU screen.

10 – 2G C.R.T. TEST

Use the C.R.T. TEST to adjust monitor colours and verify screen size.

COLOUR CHECK Screen

- ① Monitor COLOUR CHECK screen is displayed initially.
Each of the colours (red, green and blue) is darkest at the far left and gets progressively lighter (32 steps) towards the right.
Monitor brightness is set correctly if the white colour bar is black at the left edge and white at the right edge.

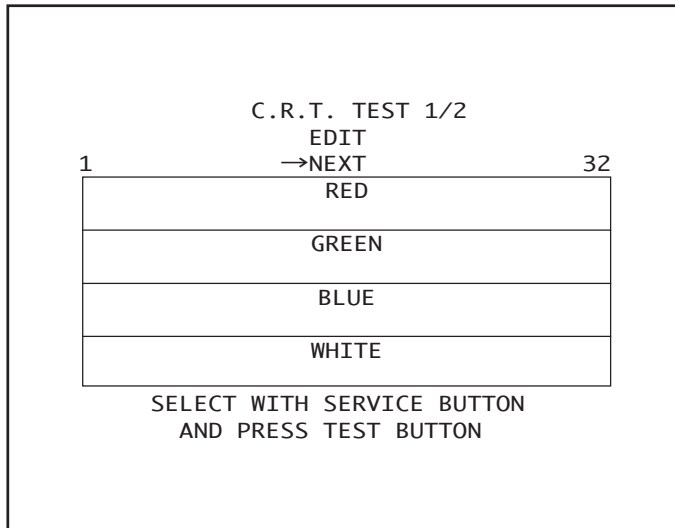

- ② Use the SERVICE Button to move the cursor to the desired test item.
- ③ Move the cursor to EDIT and press the TEST Button to enter COLOUR ADJUST mode.
- ④ Move the cursor to NEXT and press the TEST Button to enter the SIZE CHECK screen.

SIZE CHECK Screen

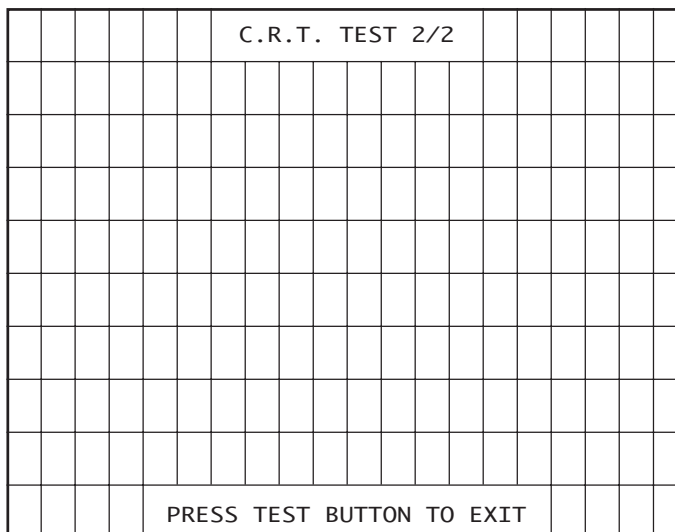

- ⑤ Adjust the CHECK GRID so that the entire GRID is displayed on the screen.
- ⑥ Press the TEST Button to return to the SYSTEM MENU screen.

COLOUR ADJUST MODE Screen

This mode is for monitors that do not have colour adjustment features.
Normally the colour should be adjusted through the monitor.

- ⑦ Use the SERVICE Button to move the cursor to the item to be adjusted.
- ⑧ Press the TEST Button to enter the selected item.

C.R.T. TEST 1/2	
VIDEO PARAMETER EDIT	
1	32
BRIGHTNESS 14	(A)
CONTRAST 26	(B)
CONTRAST_R 255	(C)
CONTRAST_G 255	(D)
CONTRAST_B 255	(E)
AUTO ADJUST	(F)
→EXIT	

SELECT WITH SERVICE BUTTON
AND PRESS TEST BUTTON

- (A) BRIGHTNESS (10 – 60)
Adjust the brightness of the screen.
 - (B) CONTRAST (10 – 44)
Adjust the colour contrast.
 - (C) CONTRAST_R (155 – 255)
Adjust the RED contrast.
 - (D) CONTRAST_G (155 – 255)
Adjust the GREEN contrast.
 - (E) CONTRAST_B (155 – 255)
Adjust the BLUE contrast.
 - (F) AUTO ADJUST
Adjust colour settings automatically.
- ⑨ Move the cursor to EXIT and press the TEST Button to enter the SIZE CHECK screen.

10 — 2H COIN ASSIGNMENTS

Use COIN ASSIGNMENTS to set the credit rate for each coin inserted.

- ① Use the SERVICE Button to move the cursor to the desired test item.
- ② Press the TEST Button to change the setting or to open the detailed settings.
- ③ Move the cursor to EXIT and press the TEST Button to return to the SYSTEM MENU screen.

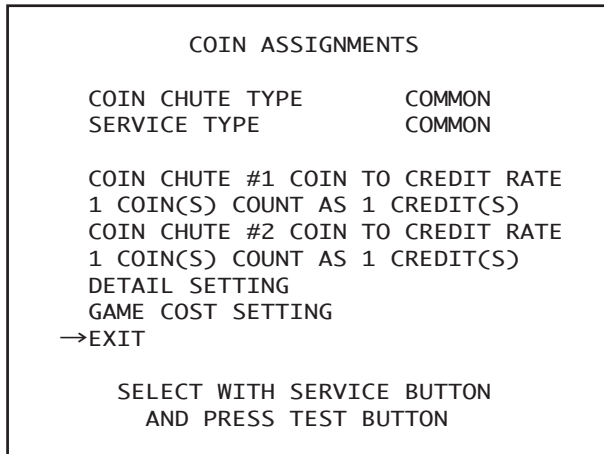

COIN CHUTE TYPE...COMMON

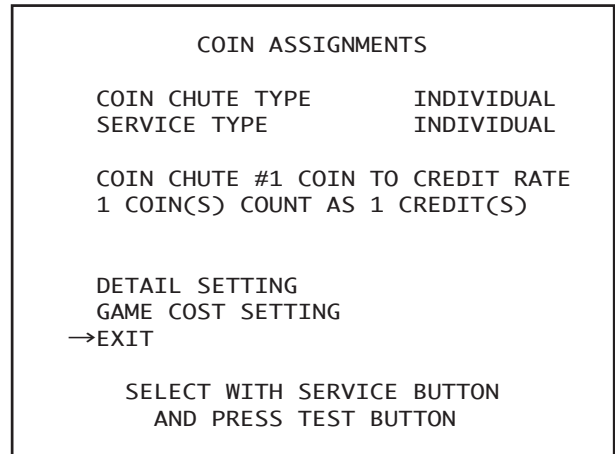

COIN CHUTE TYPE...INDIVIDUAL

(A) COIN CHUTE TYPE (COMMON, INDIVIDUAL)

Adjust settings according to the specs of the cabinet COIN CHUTE.
Set to COMMON in this game machine.

COMMON

This is for cabinets where a single COIN CHUTE is used by multiple players.

Coins inserted by each player are treated as common credits.

Up to 2 COIN CHUTES (#1 and #2) may be used. The (C) COIN TO CREDIT RATE setting for COIN CHUTE #1 and #2 may be set differently.

INDIVIDUAL

This is for cabinets with individual COIN CHUTES for each player.

Coins inserted by each player are treated as individual player credits.

The (C) COIN TO CREDIT RATE setting is used by all COIN CHUTES.

(B) SERVICE TYPE (COMMON, INDIVIDUAL)

Use this to set the function of each SERVICE Button when there is more than one SERVICE Button.

Set to COMMON in this game machine.

COMMON

Pressing any SERVICE Button enters service credits for all players.

INDIVIDUAL

Pressing the SERVICE Button enters service credits only for the corresponding player.

(C) COIN TO CREDIT RATE

Set the CREDIT RATE for each coin inserted.

The "△ COIN(S) COUNT AS □ CREDIT(S)" setting indicates that "Inserting △ coins equals □ credits".

Set this to "FREE PLAY" to allow game play without credits.

When (A) COIN CHUTE TYPE is set to "COMMON", COIN CHUTE #2 settings are restricted to some extent by the settings for COIN CHUTE #1.

(D) DETAIL SETTING

This mode allows for more detailed credit rate settings than the (C) COIN TO CREDIT RATE setting.

Changes made in DETAIL SETTING override any (C) COIN TO CREDIT RATE settings.

DETAIL SETTING Screen

```

          COIN ASSIGNMENTS
          DETAIL SETTING
COIN CHUTE #1 MULTIPLIER
  1 COIN COUNT AS 1 COIN(S)
COIN CHUTE #2 MULTIPLIER
  1 COIN COUNT AS 1 COIN(S)
BONUS ADDER          NO BONUS ADDER
COIN TO CREDIT    1 COIN(S) 1 CREDIT
→EXIT
COIN CHUTE #1 OPERATION
COIN  1  2  3  4  5  6  7  8  9
CREDIT 1  2  3  4  5  6  7  8  9
COIN CHUTE #2 OPERATION
COIN  1  2  3  4  5  6  7  8  9
CREDIT 1  2  3  4  5  6  7  8  9
          SELECT WITH SERVICE BUTTON
          AND PRESS TEST BUTTON

```

COIN CHUTE TYPE...COMMON

```

          COIN ASSIGNMENTS
          DETAIL SETTING
COIN CHUTE #1 MULTIPLIER
  1 COIN COUNT AS 1 COIN(S)
          (E)
          (E)
          (F)
          (G)
BONUS ADDER          NO BONUS ADDER
COIN TO CREDIT    1 COIN(S) 1 CREDIT
→EXIT
COIN CHUTE #1 OPERATION
COIN  1  2  3  4  5  6  7  8  9
CREDIT 1  2  3  4  5  6  7  8  9

          SELECT WITH SERVICE BUTTON
          AND PRESS TEST BUTTON

```

COIN CHUTE TYPE...INDIVIDUAL

(E) COIN CHUTE MULTIPLIER

Use this to set how many coins will be counted for each coin inserted.

The "1 COIN COUNT AS △ COIN(S)" setting indicates that "Each coin will be counted as △ coins".

When the (A) COIN CHUTE TYPE is set to "COMMON", the setting may be set individually for COIN CHUTE #1 and #2.

(F) BONUS ADDER

Use this to set the number of coins calculated with the (E) COIN CHUTE MULTIPLIER setting that need to be inserted to get 1 bonus coin. When the (A) COIN CHUTE TYPE is set to "COMMON", the sum of the coins for COIN CHUTE #1 and #2 is used for the calculation.

The "△ COINS GIVE 1 EXTRA COIN" setting indicates that "For every △ coins, 1 bonus coin is given".

Set this to "NO BONUS ADDER" to disable bonus coins entirely.

(G) COIN TO CREDIT

Use this to set how many coins calculated with the (F) BONUS ADDER setting count as 1 credit.

The "△ COIN(S) 1 CREDIT" setting indicates that "Every △ coins equals 1 credit."

(H) GAME COST SETTING

Use this mode to set the number of credits required to start a game.

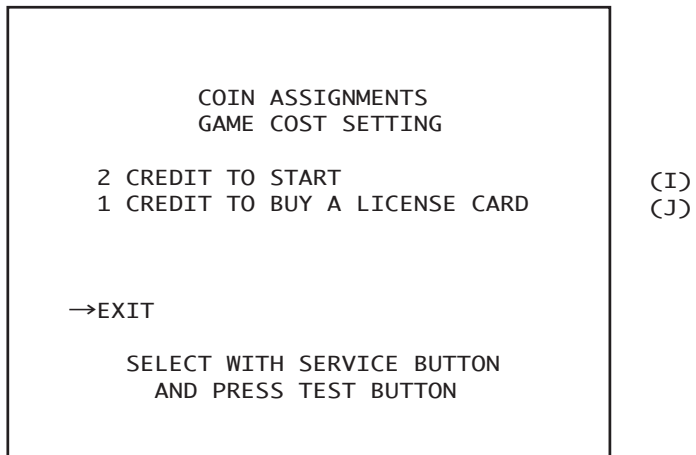

(I) Set the number of credits required to start a game.

(J) Set the number of credits required to buy a license card.

10 — 21 CLOCK SETTING

Use CLOCK SETTING to set the TRIFORCE internal clock.

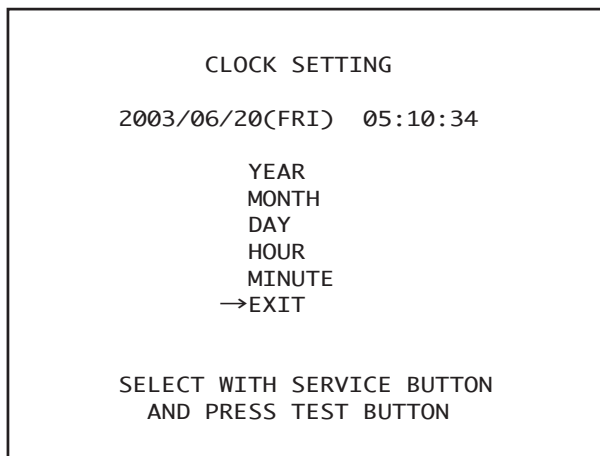

- ① Use the SERVICE Button to move the cursor to the item to be set.
- ② Move the cursor to the desired item and press the TEST Button to increase values.
The max value for YEAR is "2099"; further increases return the value to "2000".
- ③ Move the cursor to EXIT and press the TEST Button to return to the SYSTEM MENU screen.



This product should only be used with the factory settings indicated in this manual. Selecting certain options from the screens listed below may alter settings or bring up other screens. However, since these functions are not used by this machine, they are not described in this manual. In the event that settings are altered on a screen not mentioned in this manual, the machine may cease to function properly. Restore the settings to the values shown on the screens below. Refer to "10-3E Network Settings" for actual network play settings.

Use NETWORK SETTING to establish and test network connections.

- ① Use the SERVICE Button to move the cursor to the desired test item.
- ② Press the TEST Button to change the setting or to open the detailed settings.
- ③ Move the cursor to EXIT and press the TEST Button to return to the SYSTEM MENU screen.

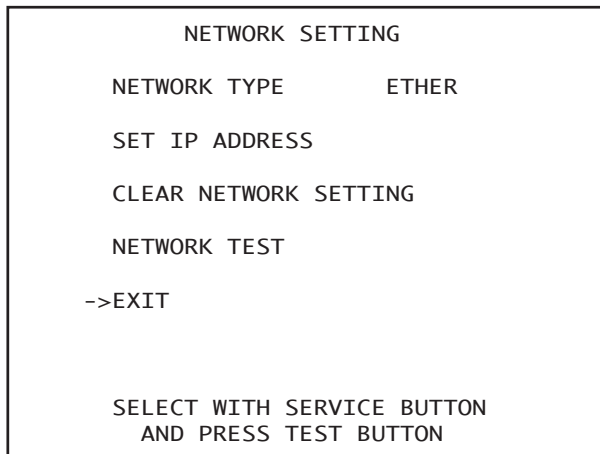

(A) NETWORK TYPE

Choose a type of the communication network.
Set to ETHER in this game machine.

NONE: Sets that the communication system does not perform. Sets to NONE when you don't set the network system.

ETHER: Sets ETHER for the communication network.

MOBILE: Sets a mobile communication terminal for the communication network.

ETHER + MOBILE

DEFAULT ETHER: Set ETHER or MOBILE automatically for the communication network. Priority is given to ETHER.

ETHER + MOBILE

DEFAULT MOBILE: Set ETHER or MOBILE automatically for the communication network. Priority is given to MOBILE.

(B) SET IP ADDRESS

This sets up the details of the communication network. Depending on the NETWORK TYPE setting, the contents of setting vary. If setting to NONE, it does not appear.

● ETHER Setting

```
          SET IP ADDRESS 1/1

REMOTE          DISABLE
IP ADDRESS(E)
*****
SUBNET MASK(E)
-----
GATEWAY(E)
-----
PRIMARY DNS
-----
SECONDARY DNS
-----
->EXIT

SELECT WITH SERVICE BUTTON
AND PRESS TEST BUTTON
```

(C)

(C) REMOTE

This option determines whether network settings will be handled automatically. For this machine, the option should be set to DISABLE.

The other items are set up automatically. It's not necessary to change anything.

10 – 3 GAME TEST MODE



- When changing the game configuration, changes will not be enabled until the Game Test Mode has been completed. Be sure to exit the Game Test Mode properly after configuration changes.
- Do not configure the game in ways not described in this text, as this may lead to game malfunctions.

10 – 3A GAME TEST MENU

Select GAME TEST MODE from the System Menu screen to display the Game Test Menu screen as follows.

Use the SERVICE Button to move the cursor to the desired test item. Press the TEST Button to enter the selected item.

After selecting an item, read the explanations below regarding operation.

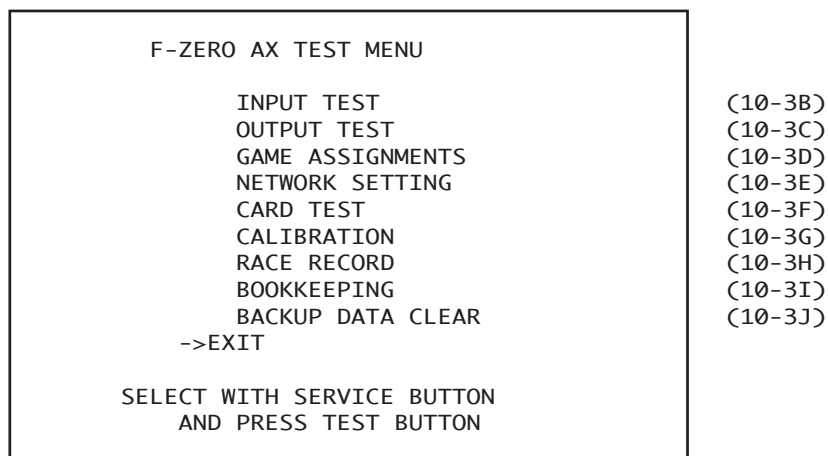

FIG. 10. 3 a GAME TEST MENU Screen

After making changes, be sure to select EXIT and press the TEST Button in order to enable the new settings.

Move the cursor to EXIT and press the TEST Button to return to the System Menu screen.



- For safe operation, do not fail to check all moving parts. If you should find anything out of the ordinary, do not allow the machine to be used.
- Entering INPUT TEST will disengage the lock on the seat. Be careful not to push the seat while the lock is disengaged, as accidents may occur.

Select INPUT TEST to display the following screen and check the status of input devices. This test should be used periodically to check that each input device is functioning correctly.

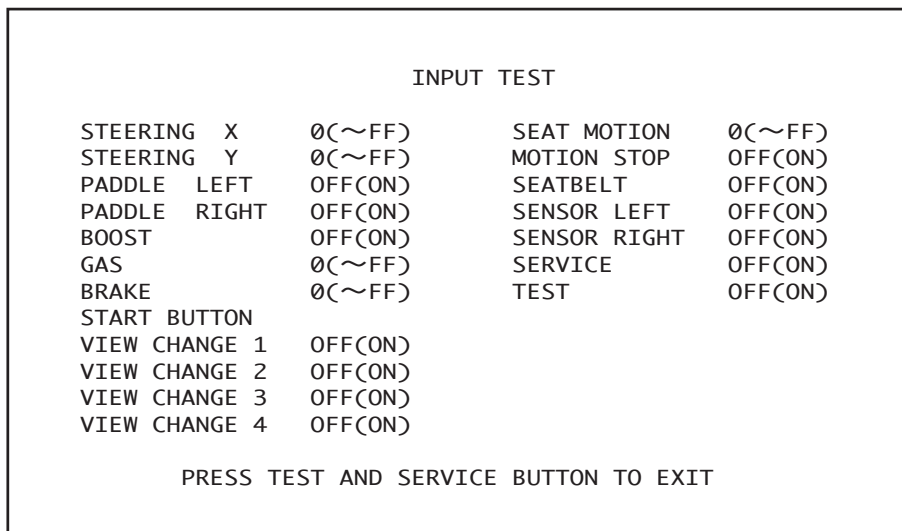

FIG. 10.3 b a INPUT TEST Screen

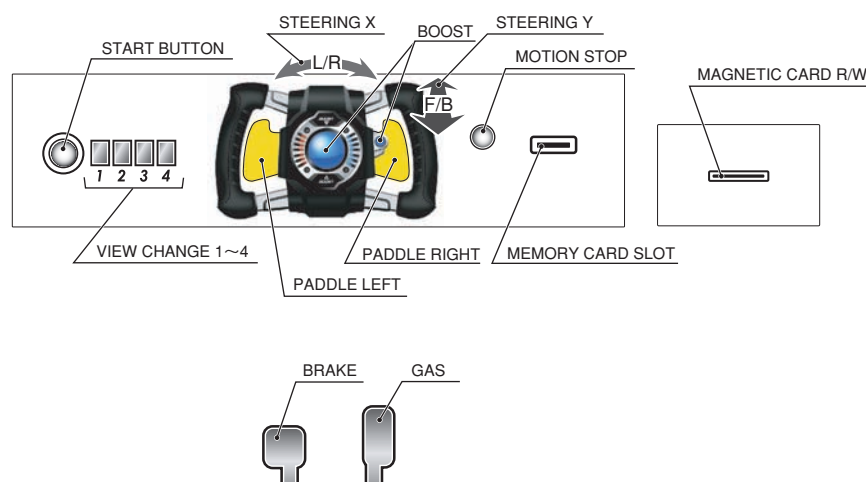

FIG. 10.3 b b

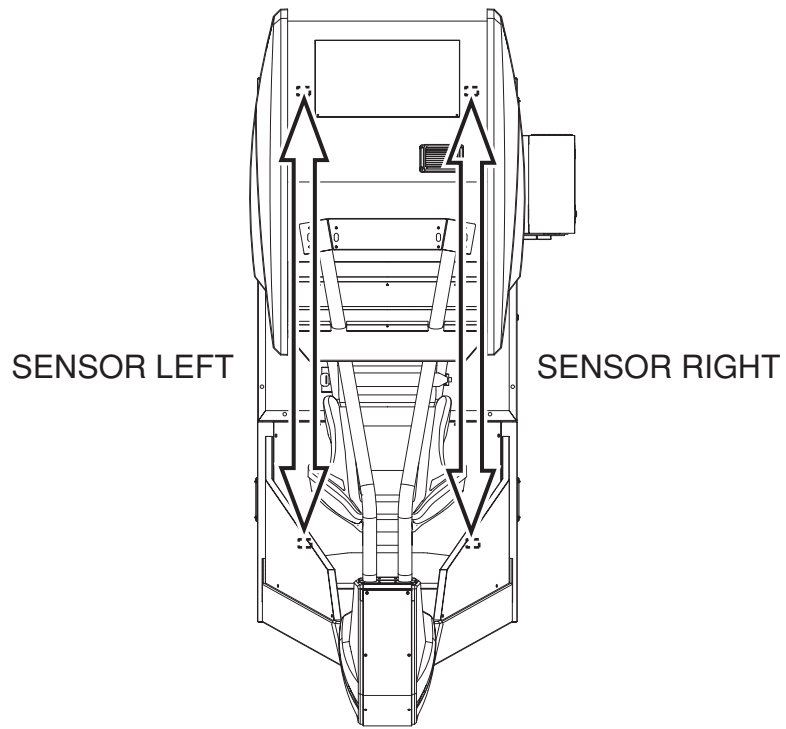

FIG. 10. 3 b c

Test the STEERING, GAS and BRAKE controls to ensure that they are functioning properly and that the parameters change smoothly as each input device is operated.

SEAT MOTION represents the value of the variable resistor that detects the angle of the seat. Tilt the seat by hand and check to make sure this value changes smoothly.

If the other input devices (switches, buttons, sensors) switch from "OFF" to "ON" when operated, they are functioning normally.

Press the SERVICE and TEST Buttons simultaneously to return to the Game Test Menu screen.



- Be sure to check the area around you before testing seat movement and operation. The moving seat may collide with surrounding objects.
- Selecting SEAT and pushing the TEST Button will cause the seat to start moving. Take care to avoid accidents when testing this device.



- To avoid injury, first check that no one is touching the steering wheel. Select OUTPUT TEST and press the TEST Button. After initialization the steering wheel will turn.
- Select STEERING and press the TEST Button to make the steering wheel turn. To avoid injury, first make sure that no one is touching the wheel.

Selecting OUTPUT TEST and pressing the TEST Button will cause the next screen to initialize and load. This allows you to check the status of each output device. This test should be used periodically to check that the lamps are functioning correctly.

OUTPUT TEST	
START BUTTON	OFF(CON)
VIEW CHANGE 1	OFF(CON)
VIEW CHANGE 2	OFF(CON)
VIEW CHANGE 3	OFF(CON)
VIEW CHANGE 4	OFF(CON)
BOOST	OFF(CON)
STEERING	
CENTER	OFF(CON)
LEFT	OFF(CON)
RIGHT	OFF(CON)
SEAT	
LOCK	OFF(CON)
CENTER	OFF(CON)
LEFT	OFF(CON)
RIGHT	OFF(CON)
-> EXIT	
SELECT WITH SERVICE BUTTON AND PRESS TEST BUTTON	

FIG. 10. 3 c a OUTPUT TEST Screen

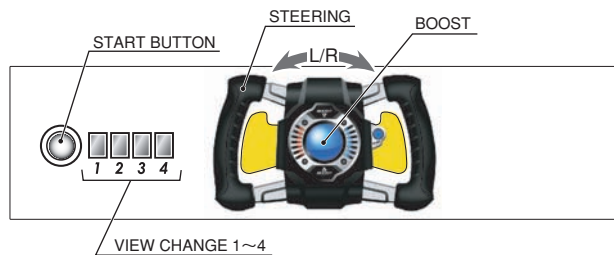

FIG. 10. 3 c b

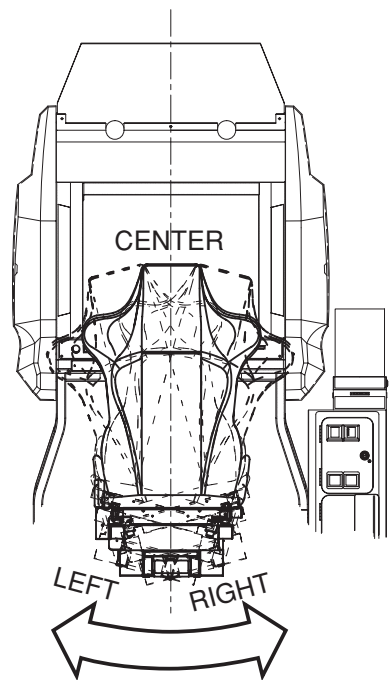

FIG. 10. 3 c c

The START BUTTON, VIEW CHANGE 1-4, and BOOST allow you to check the status of the lights on top of the control panel. Select each item and press the TEST Button to turn the respective light on and off as indicated by the display to the right of the item.

Come to this screen periodically to check that the lamps light up with ON and turn off with OFF.

When you select STEERING or SEAT and press the TEST Button, it will move in the selected direction for a set period of time and stop. SEAT LOCK locks the seat in place.

Move the cursor to EXIT and press the TEST Button to return to the Game Test Menu screen.

10 — 3D GAME ASSIGNMENTS

Select GAME ASSIGNMENTS to display the current game settings and make changes. Periodically come to this screen to check game settings.

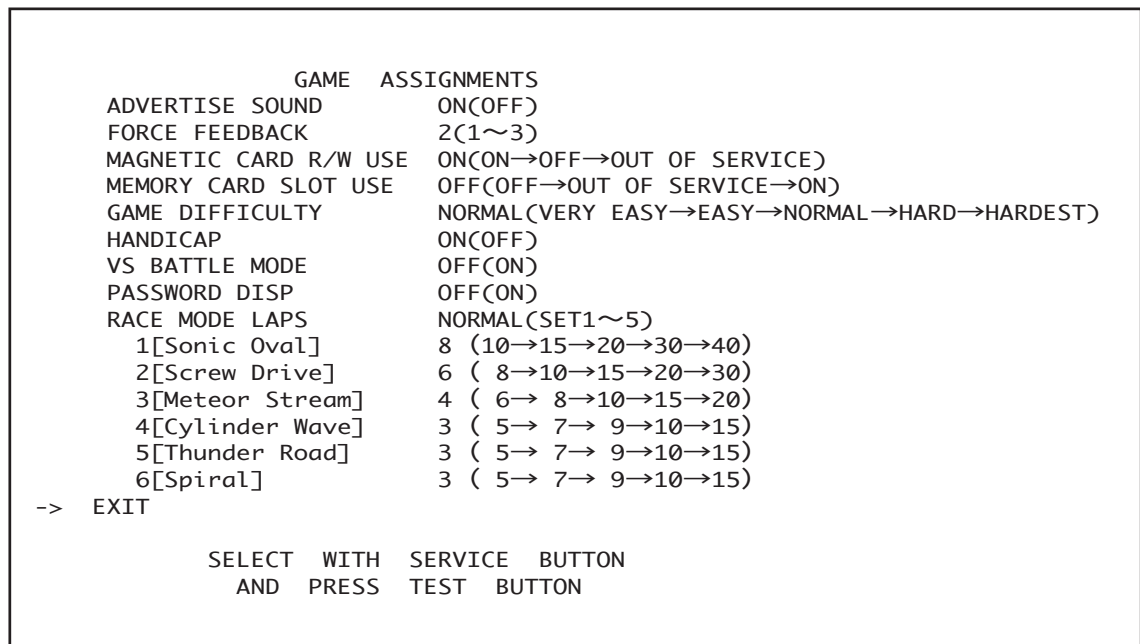

FIG. 10. 3 d GAME ASSIGNMENTS

Press the SERVICE Button and move the cursor to the setting you wish to change. Press the TEST Button to cycle the parameters on the left of the item through its various settings.

Note that GAME DIFFICULTY, HANDICAP, VS BATTLE MODE, PASSWORD DISP and RACE MODE LAPS are shown on the machine whose NUMBER on the NETWORK SETTING screen is set to 1.

Changing the configuration of the NUMBER 1 machine automatically follows the settings of the other numbered machines.

● ADVERTISE SOUND

Turn advertising sound output ON and OFF.
(Default setting: ON)

● FORCE FEEDBACK

There are three settings for steering resistance. (Default setting: 2)

- 1: Weak
- 2: Normal
- 3: Strong

● MAGNETIC CARD R/W USE

Configure the usability of the card reader/writer. Turn the card reader/writer on and off. (Default setting: ON)

Set it to ON if you want to activate card reader/writer, and to OUT OF SERVICE or OFF if a malfunction or other factor makes the card reader/writer unusable.

- If you set this option to OUT OF SERVICE, the advertising loop (demo screen) will display the message, "The F-ZERO LICENSE CARD can not be used or purchased at this time," and users will be unable to play with license cards.
- If you set this option to OFF, no message regarding license cards will be shown during the advertising loop.

● MEMORY CARD SLOT USE

Configure Nintendo GameCube Memory Card usage. This option lets you enable or disable the memory card slot. (Default setting: ON)

- Set this option to ON to enable compatibility with F-ZERO GX for the Nintendo GameCube. Note that this option cannot be used if the player does not have F-ZERO GX game data. Please set this option to OUT OF SERVICE or OFF until F-ZERO GX is released.
- If you set this option to OUT OF SERVICE, the advertising loop will display the message, "Can not use Nintendo GameCube Memory Card."
- If you set this option to OFF, no message regarding the Memory Card will be shown during the advertising loop.
We recommend that you set this option to OFF until F-ZERO GX is released.

NOTES:

- * If both license cards and memory cards are set to OUT OF SERVICE, the advertising loop will display the message, "Cards cannot be used."
- * If both are set to OFF, no message will be shown.
- * If one of the two is set to OUT OF SERVICE, the message specific to that card will be shown.
- * If one is set to OUT OF SERVICE and the other to OFF, no card instructions will be shown during the advertising loop.

● GAME DIFFICULTY

Set the game's difficulty level to five settings: VERY EASY, EASY, NORMAL, HARD, and HARDEST. (Default setting: NORMAL)

This changes the amount of bonus time given at checkpoints and the speed of COM machines (Race Mode only).

● HANDICAP

Turns the Race Mode (COM battles, player battles) handicap ON or OFF. (Default setting: ON)

● VS BATTLE MODE

Sets COM machine participation in Race Mode ON or OFF. (Default setting: OFF)

When set to ON, players race only against other players.

However, note that COM machines will join in Single Mode and Play Solo Even when in Linked Mode.

● PASSWORD DISP

Turn password display during Time Attack Mode ON and OFF. When set to ON, the password screen is shown after racing in Time Attack Mode. This password lets users join the F-ZERO Internet Rankings via their home computers. Please set this to OFF if Internet Rankings are not being listed. The launch of Internet Rankings will be announced on the Official F-ZERO Home Page, <http://f-zero.jp/>. (Default setting: ON)

● RACE MODE LAPS

In Race Mode, there are six setting levels for the number of laps; Normal and Settings 1 to 5. (Default setting: NORMAL). The game features six courses, and the number to the left of each course is its number of laps. The number of laps in Time Attack Mode cannot be changed.

Changes to settings are not enabled until Test Mode is exited. After changing settings, be sure to exit Test Mode.

After changing the settings, select EXIT and press the TEST Button to return to the Game Test Menu screen.

10 — 3E NETWORK SETTING

Select NETWORK SETTING to display the following screen and configure linked play settings.

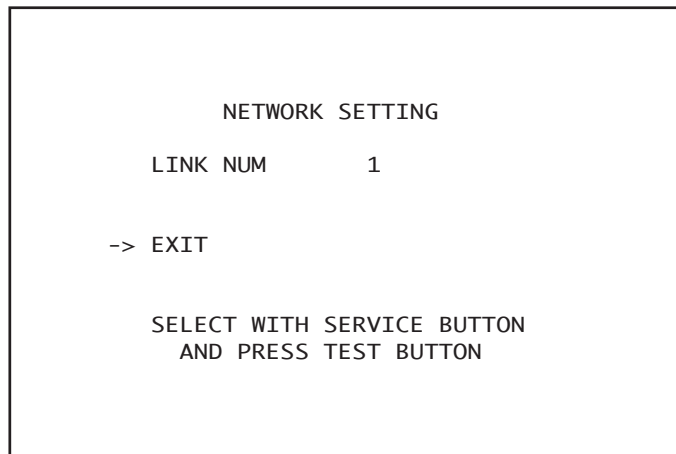
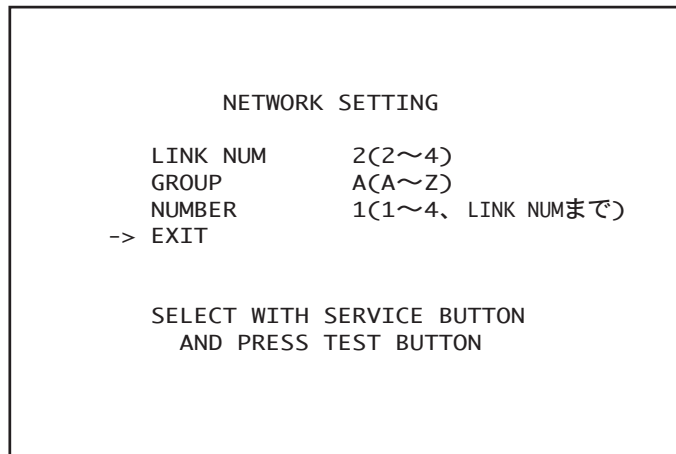

FIG. 10. 3 e NETWORK SETTING Screen

Press the SERVICE Button and move the cursor to select an option to change. Press the TEST Button to cycle through the settings shown to the left of the item.

● LINK NUM

Set the number of game machines to link. Set this to "1" for the single setting. "2" or more allows linked play. You will need to set up groups and configure the NUMBER to enable linked play.

● GROUP

Used to set groups among the linked machines. For instance, if four machines are connected and you want two groups of two, set two to "A" and the other two to "B." Ensure that you always have a group "A".

● NUMBER

Assigns a number for each machine within a group. Do not use the same number twice in one group. Also note that you must set one machine as "1."

Changing the GAME DIFFICULTY, HANDICAP, VS BATTLE MODE, PASSWORD DISP, and RACE MODE LAPS settings of the "1" machine will automatically change the settings of machines numbered "2" to "4."

After changing the settings, select EXIT and press the TEST Button to return to the Game Test Menu screen.

Test the functionality of or clean the card read/writer. The card read/writer should be tested and cleaned periodically.



- Clean the card reader/writer periodically.
- Set the TRIFORCE's internal clock to the correct time (see section 10-21). If the internal clock is not set to the correct time, card play may be turned off at a different time from the one intended.

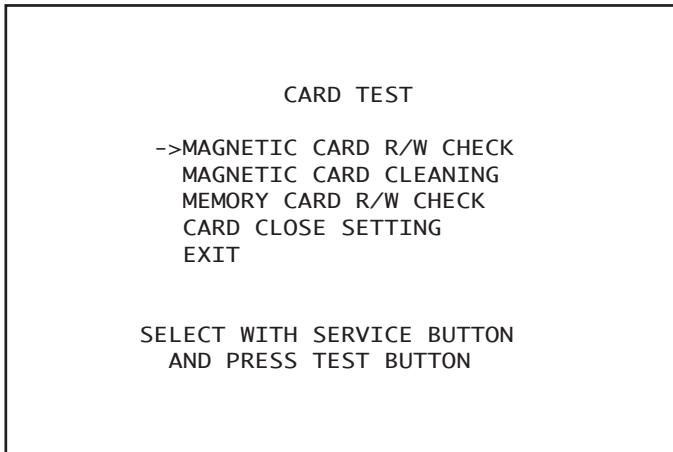

FIG. 10. 3 f a CARD TEST Screen

● **MAGNETIC CARD R/W CHECK**

Checks the card reader/writer.

When checking, the message "Checking the card reader/writer" is shown and a read test, write test, and print test are automatically performed. Checking uses up one magnetic card.

If the test is completed without an error, the machine dispenses the card from the card reader/writer slot and posts a message asking you to remove the card. When the card has been taken, the screen reads "Succeeded to read/write."

If an error occurs, the screen produces an error display (see 18-1). If the error persists, try cleaning the read/write heads.

● **MAGNETIC CARD CLEANING**

This allows you to clean the card reader/writer head. For instructions on handling the cleaning card, see "7-2 Head Cleaning".

- 1) Select MAGNETIC CARD CLEANING and press the TEST Button. The message "Insert the CLEANING CARD." will appear on the screen.
- 2) Insert the cleaning card into the card slot.
- 3) When cleaning is complete, the cleaning card will be automatically ejected and the user will be instructed to "Retrieve the CLEANING CARD."
- 4) Remove the cleaning card and throw it away. When the card has been removed, the screen reads "Succeeded to cleaning."

● MEMORY CARD R/W CHECK

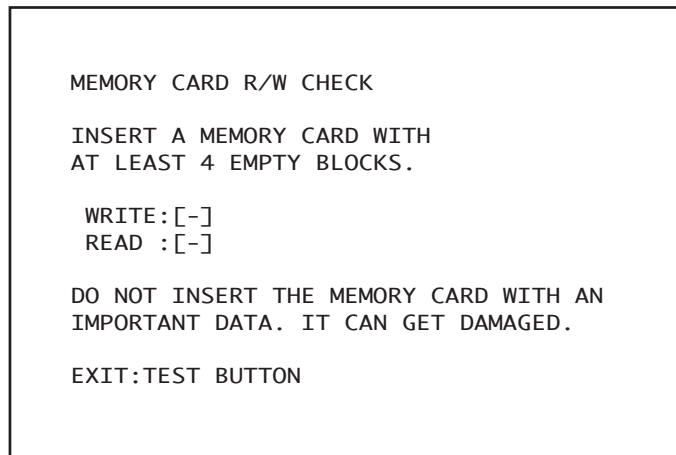

FIG. 10. 3 f b MEMORY CARD SLOT CHECK Screen (1)

This checks the Memory Card slot. To perform the check, you will need a Nintendo GameCube Memory Card with four blocks of free space.

Note that there is a chance of data loss. Do not use a Memory Card that contains important information.

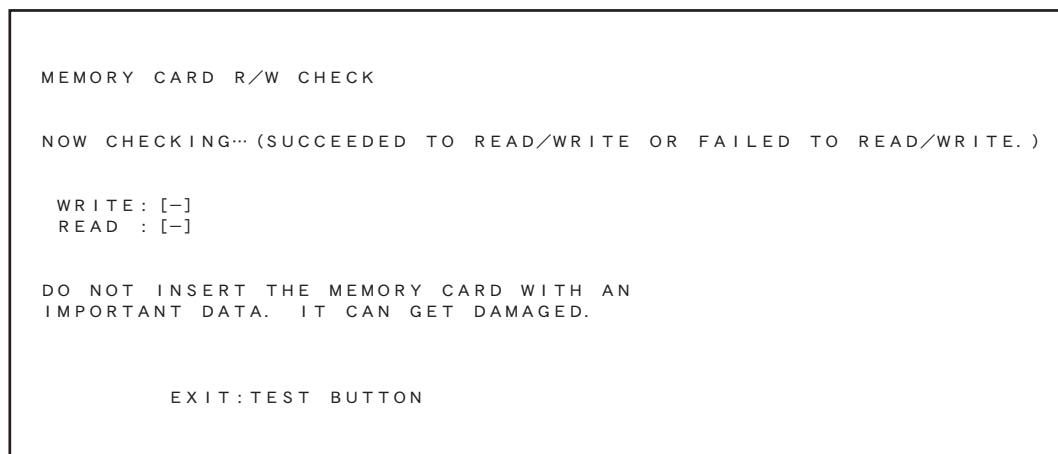

FIG. 10. 3 f b MEMORY CARD SLOT CHECK Screen (2)

Insert the Memory Card to automatically begin reading and writing tests. Re-insertion is directed when the Card is already inserted.

If all goes well, "NOW CHECKING..." will switch to "SUCCEEDED TO READ/WRITE." and a circle [○] will appear by each item.

If there is a problem, the message "FAILED TO READ/WRITE" will appear and an "X" will be displayed by each item.

If the " × " continues to appear after repeated tests with different memory cards, check the wiring. If you cannot find anything wrong with the wiring, you will need to replace the Memory Card slot.

● CARD CLOSE SETTING



Users will be unable to use their cards during the time(s) that you set. Be sure to set the appropriate time(s) based on the circumstances.

This allows you to assign the "card close" times. Players will not be able to use their cards from the time that you set; cards will remain unusable until the power is reset.

Be sure to set the appropriate time given the circumstances. For instance, if you close at midnight, try setting the time to fifteen minutes before closing, at 11:45.

If you have set RACE MODE LAPS to SET5, the large number of laps may take some time to complete, so 30 minutes before closing time (11:30) might be more appropriate.

There are three ways to set the "card close": WEEK, DAY, and OFF. Set the cursor to DAY and press the TEST Button to change the type.

Day Time Settings

Use this to set the "card close" time to be the same every day. Configure in the same way as with WEEK.

(The default setting is 23:45.)

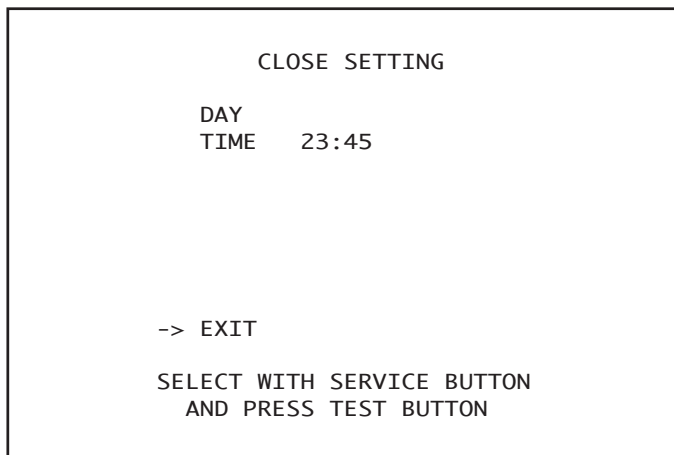

FIG. 10. 3 f d CLOSE SETTING (DAY) Screen

Weekly Time Settings

Set the "card close" time for each day. Press the SERVICE Button to select the day and the TEST Button to change the time. Times can be changed in fifteen-minute intervals. (The default setting is 0:45 for Friday, Saturday and Sunday, and 23:45 for other days.)

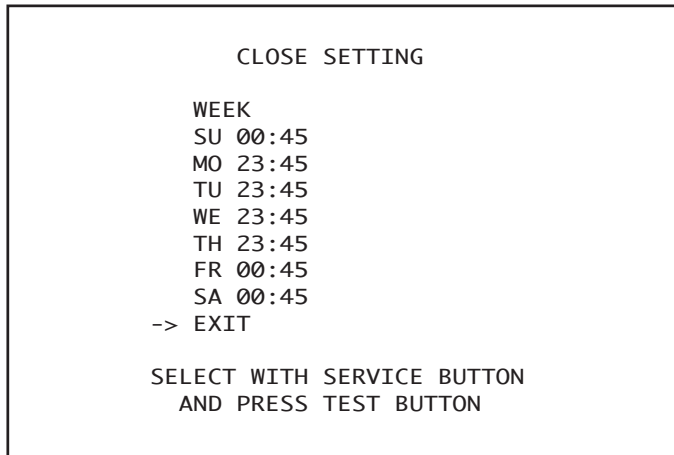

FIG. 10. 3 f c CLOSE SETTING (WEEK) Screen

The OFF Setting

Disable "card close" setting.

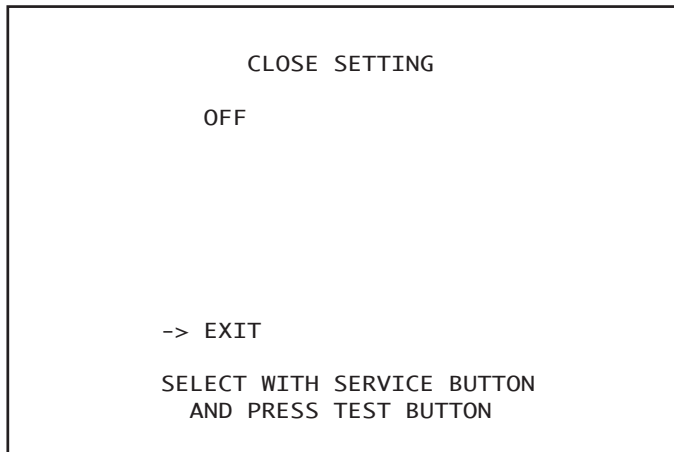

FIG. 10. 3 f e CLOSE SETTING (OFF) Screen

After changing the settings, select EXIT and press the TEST Button to return to the Game Test Menu screen.



To calibrate the input devices, be sure to move them to their maximum extent. The input devices will not be calibrated unless the number displayed exceeds "10".

Calibration adjusts the controls to eliminate inconsistencies.

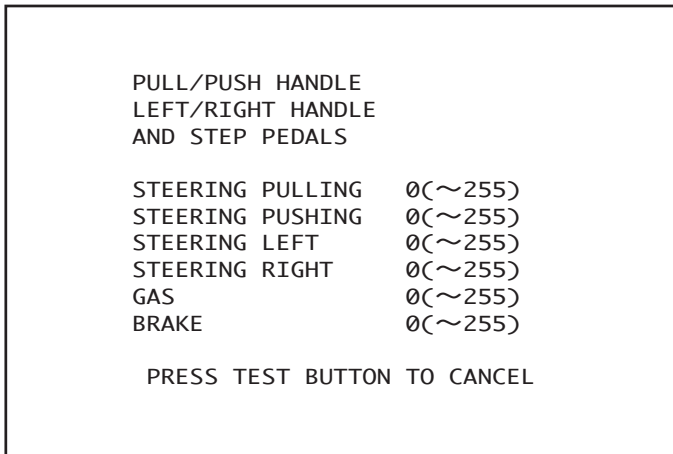

FIG. 10. 3 g CALIBRATION Screen

This calibrates the input magnitudes for the steering wheel, accelerator (GAS), and brake. To calibrate the steering wheel, move the handle all the way up, down, right and left, and press the pedal all the way down. The adjustments made to the values with this program are reflected in the game's controls.

After the input devices have been moved and their input values adjusted, the screen display will change from "PRESS TEST BUTTON TO CANCEL" to "PRESS TEST BUTTON TO EXIT". Press the TEST Button to return to the menu screen; the input devices will be calibrated to reflect the input values.

If the TEST Button is pressed while the screen displays "PRESS TEST BUTTON TO CANCEL", the input devices will not be calibrated.

Press the TEST Button to return to the Game Test Menu screen.

10 — 3H RACE RECORD

Select RACE RECORD to display the twelve screens of play data.

Press the TEST Button to cycle through each screen from (1/12) to (12/12). Pressing the TEST Button while the (12/12) screen is displayed returns you to the Game Test Menu.

RACE RECORD 1/12	
NUMBER OF GAMES	00
LICENSE CARD PLAY	00
LICENSE CARD BUY	00
MEMCARD PLAY	00
LINK VS PLAY	00
PRESS TEST BUTTON TO CONTINUE	

FIG. 10. 3 h a RACE RECORD (1/12) Screen

- NUMBER OF GAMES: Total number of games
- LICENSE CARD PLAY: Number of times license cards have been used
- LICENSE CARD BUY: Number of license cards sold
- MEMCARD PLAY: Number of times players have played using the Memory Card
- LINK VS PLAY: Number of times link play has been played

RACE RECORD 2/12					
MACHINE DATA					
Machine	Play	Col 1	Col 2	Col 3	Col 4
ORIGINAL	0	0	0	0	0
BFALCON	0	0	0	0	0
GFOX	0	0	0	0	0
WGOOSE	0	0	0	0	0
FSTING	0	0	0	0	0
RAINP	0	0	0	0	0
SMOON	0	0	0	0	0
RTURTLE	0	0	0	0	0
CDOLPHIN	0	0	0	0	0
SRAT	0	0	0	0	0
PINKS	0	0	0	0	0
BFLASH	0	0	0	0	0
MGULL	0	0	0	0	0
GTAXI	0	0	0	0	0
FATS	0	0	0	0	0
PRESS TEST BUTTON TO CONTINUE					

FIG. 10. 3 h b RACE RECORD (2/12) Screen

Shows the machines and colors chosen by the players.

RACE RECORD 3/12

VS COURSE DATA

Course	Play	Runall	destroy		courseout		burst	
			AVG	MAX	AVG	MAX	AVG	MAX
1	0	0	0.0	0	0.0	0	0.0	0
2	0	0	0.0	0	0.0	0	0.0	0
3	0	0	0.0	0	0.0	0	0.0	0
4	0	0	0.0	0	0.0	0	0.0	0
5	0	0	0.0	0	0.0	0	0.0	0
6	0	0	0.0	0	0.0	0	0.0	0

PRESS TEST BUTTON TO CONTINUE

FIG. 10. 3 h c RACE RECORD (3/12) Screen

Race Mode play data by course.

- Course: Course number
- Play: Times played
- Runall: Number of times completed
- destroy: Number of rival cars which have been destroyed in a single game (shows average and maximum)
- courseout: Number of times the player has run off course in a single game (shows average and maximum)
- burst: Number of times the player's machine has been destroyed in a single game (shows average and maximum)

RACE RECORD 4/12

VS COURSE RANK DATA

COURSE	1	2	3	4	5	6
RANK 1	0	0	0	0	0	0
RANK 2	0	0	0	0	0	0
RANK 3	0	0	0	0	0	0
RANK 4	0	0	0	0	0	0
RANK 5	0	0	0	0	0	0
RANK 6	0	0	0	0	0	0
RANK 7	0	0	0	0	0	0
RANK 8	0	0	0	0	0	0
RANK 9	0	0	0	0	0	0
RANK 10	0	0	0	0	0	0
RANK 11	0	0	0	0	0	0
RANK 12	0	0	0	0	0	0
RANK 13	0	0	0	0	0	0
RANK 14	0	0	0	0	0	0
RANK 15	0	0	0	0	0	0
RANK 16	0	0	0	0	0	0
RANK 17	0	0	0	0	0	0
RANK 18	0	0	0	0	0	0
RANK 19	0	0	0	0	0	0
RANK 20	0	0	0	0	0	0
RANK 21	0	0	0	0	0	0
RANK 22	0	0	0	0	0	0
RANK 23	0	0	0	0	0	0
RANK 24	0	0	0	0	0	0
RANK 25	0	0	0	0	0	0
RANK 26	0	0	0	0	0	0
RANK 27	0	0	0	0	0	0
RANK 28	0	0	0	0	0	0
RANK 29	0	0	0	0	0	0
RANK 30	0	0	0	0	0	0

PRESS TEST BUTTON TO CONTINUE

FIG. 10. 3 h d RACE RECORD (4/12) Screen

Shows rank information by course for Race Mode.

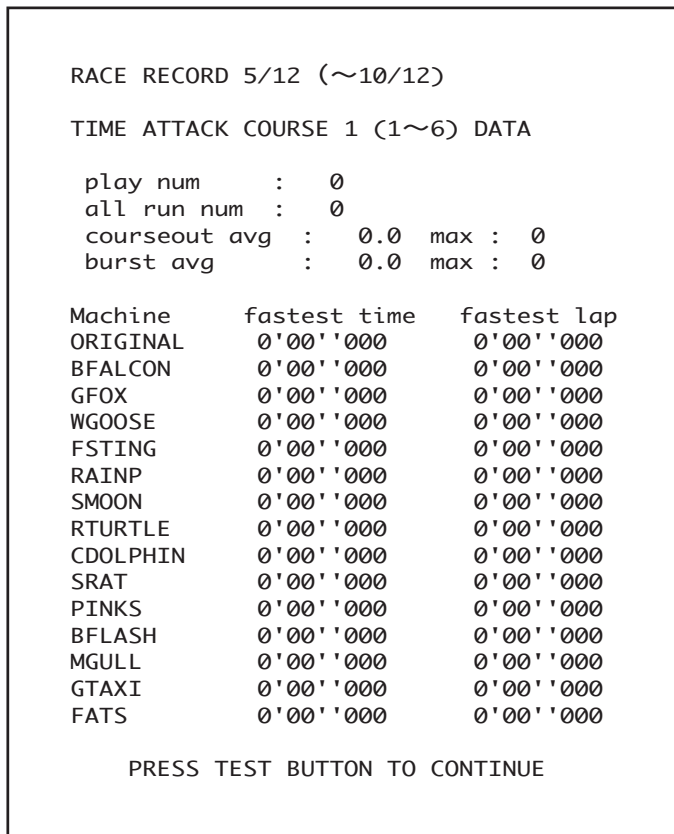

FIG. 10. 3 h e RACE RECORD (5/12) Screen

This is play data by course for Time Attack Mode. Course-specific information is shown on screens (5/12) through (10/12). Press the TEST Button to change the screen (the number "X" will change in the TIME ATTACK COURSE "X" DATA title).

- play num: The number of times each course has been played
- all run num: The number of times races have been completed
- courseout: The number of times players have run off the course (shows average and maximum)
- burst: The number of times machines have exploded (shows average and maximum)

RACE RECORD 11/12

GARAGE GET PARTS

NAME	BUY/DISP	RATE
Brave Eagle	0/0	0%
Giant Planet	0/0	0%
Megalo Cruiser	0/0	0%
Splash Whale	0/0	0%
Wild Chariot	0/0	0%
Holy Spider	0/0	0%
Optical Wing	0/0	0%
Dread Hammer	0/0	0%
Silver Sword	0/0	0%
Space Cancer	0/0	0%
Wonder Worm	0/0	0%
Combat Cannon	0/0	0%
Cyber Fox	0/0	0%
Heat Snake	0/0	0%
Rave Drifter	0/0	0%
Spark Bird	0/0	0%
Dank Chaser	0/0	0%
Crystal Egg	0/0	0%
Red Rex	0/0	0%
Sonic Soldier	0/0	0%
Euros-01	0/0	0%
Triangle-GT	0/0	0%
Bluster-X	0/0	0%
Devilfish-RX	0/0	0%
Extreme-ZZ	0/0	0%
Punisher-4X	0/0	0%
Impulse Z20	0/0	0%
Meteor-RR	0/0	0%
Jupiter-Q	0/0	0%
Comet-V	0/0	0%

PRESS TEST BUTTON TO CONTINUE

FIG. 10. 3 h f RACE RECORD (11/12) Screen

Shows information regarding parts swapped in the Configuration Screen. The denominator is the number of times the part has appeared, and the numerator is the number of times it has been acquired.

RACE RECORD 12/12

PILOT POINT

COURSE	AVG POINT	MAX POINT	MIN POINT
1	000	0000	100
2	000	0000	100
3	000	0000	100
4	000	0000	100
5	000	0000	100
6	000	0000	100

PRESS TEST BUTTON TO EXIT

FIG. 10. 3 h g RACE RECORD (12/12) Screen

Shows pilot points earned by course.

10 — 3I BOOKKEEPING

Select BOOKKEEPING to display three screens of operating status data.

Press the TEST Button to cycle through each screen from (1/3) to (3/3). Pressing the TEST Button while the (3/3) screen is displayed returns you to the Game Test Menu.

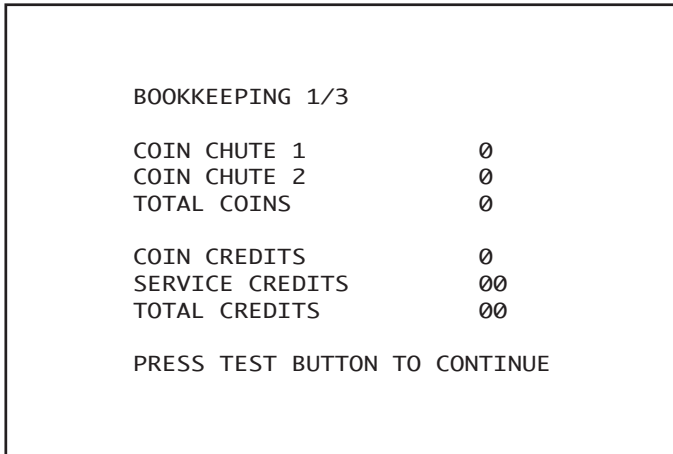

FIG. 10. 3 i a BOOKKEEPING (1/3) Screen

- COIN CHUTE 1 : Number of coins inserted into Coin Slot 1.
- COIN CHUTE 2 : Number of coins inserted into Coin Slot 2.
- TOTAL COINS : Total number of coins inserted into the coin slots.
- COIN CREDITS : Number of credits for the coins inserted.
- SERVICE CREDITS : Number of credits input by the SERVICE Button.
- TOTAL CREDITS : Total credits from coins and the SERVICE Button.

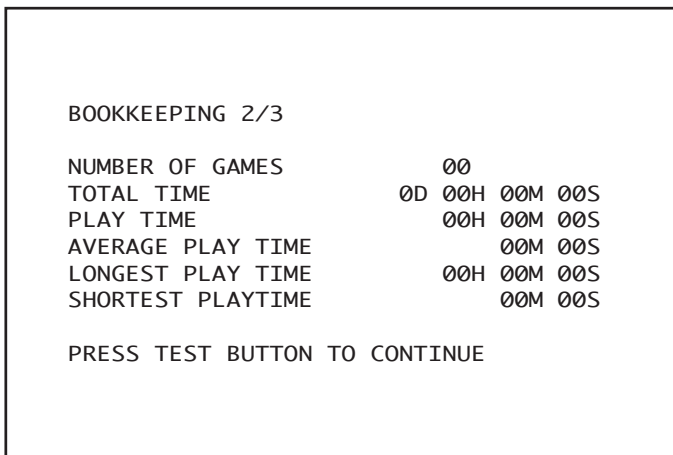

FIG. 10. 3 i b BOOKKEEPING (2/3) Screen

- NUMBER OF GAMES: Total number of games played
- TOTAL TIME: Powered-up time (length of time the machine has been on)
- PLAY TIME: Total playing time
- AVERAGE PLAY TIME: Average game play time
- LONGEST PLAY TIME: Longest game play time
- SHORTEST PLAY TIME: Shortest game play time

BOOKKEEPING 3/3		
TIME HISTOGRAM		
0M00S	~ 0M29S	00
0M30S	~ 0M59S	00
1M00S	~ 1M29S	00
1M30S	~ 1M59S	00
2M00S	~ 2M29S	00
2M30S	~ 2M59S	00
3M00S	~ 3M29S	00
3M30S	~ 3M59S	00
4M00S	~ 4M29S	00
4M30S	~ 4M59S	00
5M00S	~ 5M29S	00
5M30S	~ 5M59S	00
6M00S	~ 6M29S	00
6M30S	~ 6M59S	00
OVER	7M00S	00
PRESS TEST BUTTON TO EXIT		

FIG. 10.3 i c BOOKKEEPING (3/3) Screen

TIME HISTOGRAM shows the number of plays and the respective play times. This histogram should be referred to when setting the Game Difficulty.

10 — 3J BACKUP DATA CLEAR

Select BACKUP DATA CLEAR to clear the contents of RACE RECORD and BOOKKEEPING. Game settings and other data besides RACE RECORD and BOOKKEEPING will not be affected.

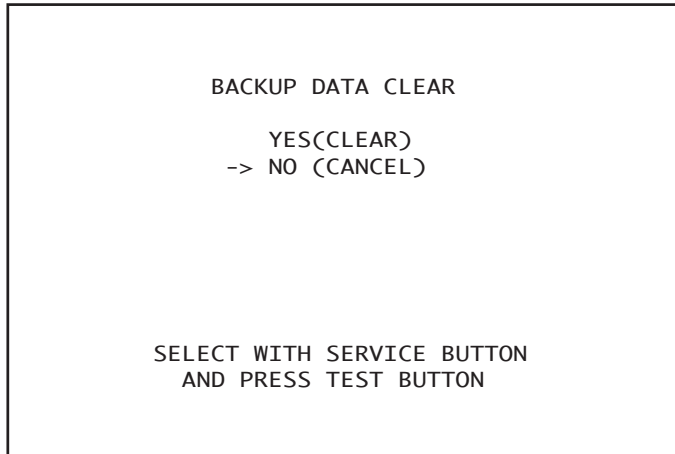

FIG. 10. 3 j BACKUP DATA CLEAR Screen

To clear data, use the SERVICE Button to move the cursor to YES (CLEAR) and then press the TEST Button. When the data has been cleared, the message "COMPLETED" will be displayed.

Press the TEST Button again to return to the Game Test Menu screen.

Move the cursor to NO (CANCEL) and press the TEST Button to return to the Game Test Menu screen without clearing the data.

Note that when you clear this data, information about the number of times the card reader/writer has been used will also be cleared. After data clearing the machine moves directly to card reader/writer head cleaning mode. Refer to "7-2 Head Cleaning", when performing head cleaning.

11. STEERING UNIT



- In order to prevent an electric shock and short circuit, be sure to turn power off before performing work by touching the interior parts of the product.
- Be careful not to damage the wires. Damaged wires may cause electric shock or short circuit or present a fire risk.
- Do not touch undesignated places. Touching places not designated can cause electric shock or short circuit.
- This work should be performed by the site maintenance individual or other skilled professional. Performing work by non-technical personnel can cause electric shock hazard.
- Do not perform work other than those specified in this Manual in order to prevent accidents during performing work and operation after performing work. Performing work not specified in this Manual may require special training for this product. If performing work other than those stated in this manual is required for repair, contact the offices herein stated in this manual or where you purchased the product from and ask for repair or inquire how to repair.
- Be very careful when soldering. Handling a soldering iron carelessly may result in a fire or a burn.
- Be extremely careful when heating the heat-shrinkable tube. Failure to do so may result in a fire or burns.
- After making adjustments or replacements, check the surrounding area before turning the power on. The machine will automatically go through initialization after the power is turned on, and any persons in the vicinity may be struck and/or knocked down by the moving seat.



- Exercise extreme caution when handling the internal parts of the Steering Unit. Watch out for damage, warping and loss. The loss of just one piece may result in damage to or lead to faulty operation of the entire unit.
- When securing the plastic-made parts, do not excessively fasten screws and nuts. Failure to observe this may damage the parts and cause injury due to fragments resulting from damage.



- When adjusting or changing the variable resistor, set the variable resistor values on the Volume Settings screen and check the values on the Input Test screen in Test mode.
- After adjusting or replacing a microswitch, be sure to verify that the switch turns on and off correctly on the Input Test screen in Test mode.

If steering unit response is less than ideal and adjusting the settings on the Volume Settings screen in Test mode has no effect, the problem is most likely due to an incorrectly engaged gear, an improperly placed microswitch, or a broken variable resistor or microswitch.

Follow the steps listed below to correct the gear engagement, adjust the position of the switch, or replace the variable resistor or switch.

Refer to Section 12, "Maintaining the Base Interior", for instructions on how to: adjust and replace the direction control variable resistor.

11 — 1 ADJUSTING AND REPLACING THE Y-AXIS VR

The variable resistor that detects the forward and backward tilting operation of the steering unit is called the Y-axis steering VR. Follow the steps listed below to adjust the gear engagement or replace the VR.

In this machine, the VR will not be damaged as long as its axle is rotating within its range of motion when the handles on the machine are tilted to their maximum extent. Secure the VR so that its axle points in the indicated direction and the gear is properly engaged when the handles are not being tilted.

The following tools and instruments are required to perform these operations:

- 3mm diameter hexagonal screwdriver or wrench
- M4-size Phillips screwdriver
- 1.5mm diameter hexagonal screwdriver or wrench
- 10mm diameter spanner
- Soldering iron

ADJUSTMENT PROCEDURE

- ① Turn off the power.
- ② Remove the 4 hexagonal socket screws around the boost button.

HEXAGONAL SOCKET SCREW (4), black
M4×10, chrome

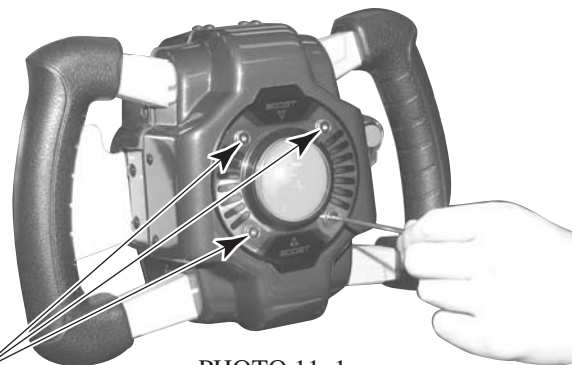

- ③ Remove the 4 truss screws holding the top and bottom of the front steering cover in place.

TRUSS SCREW (4), black
M4×6

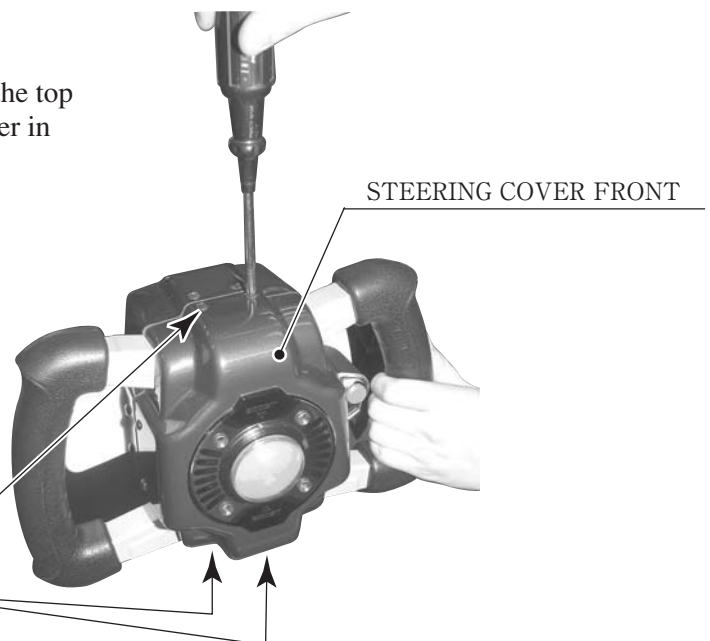

- ④ Remove the 4 truss screws holding the left and right sides of the front steering cover in place.

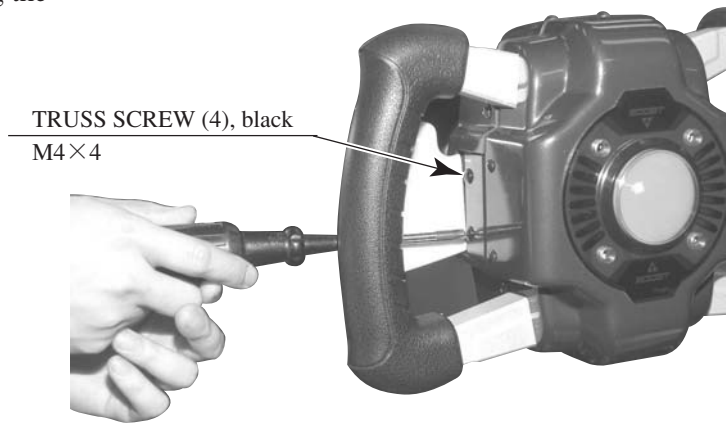

PHOTO 11. 1 c

- ⑤ Detach the front steering cover. There are several wires connected to the inside of the cover. Remove the cover slowly and unplug the connectors, taking care not to damage the wiring.

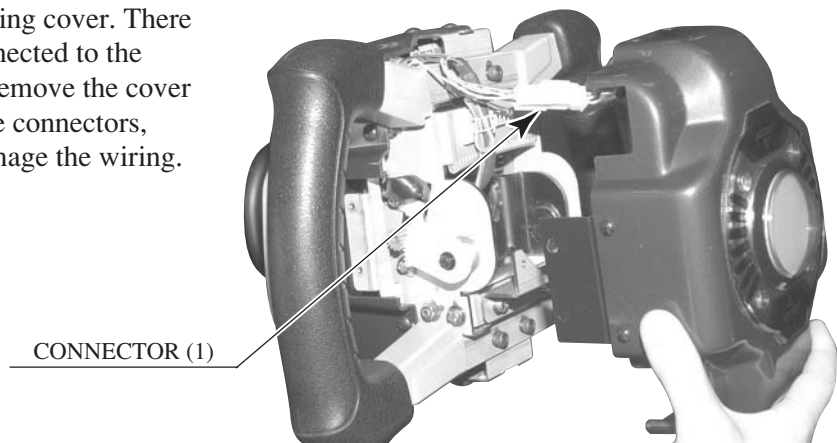

PHOTO 11. 1 d

- ⑥ Remove the 4 truss screws holding the top and bottom of the rear steering cover in place.

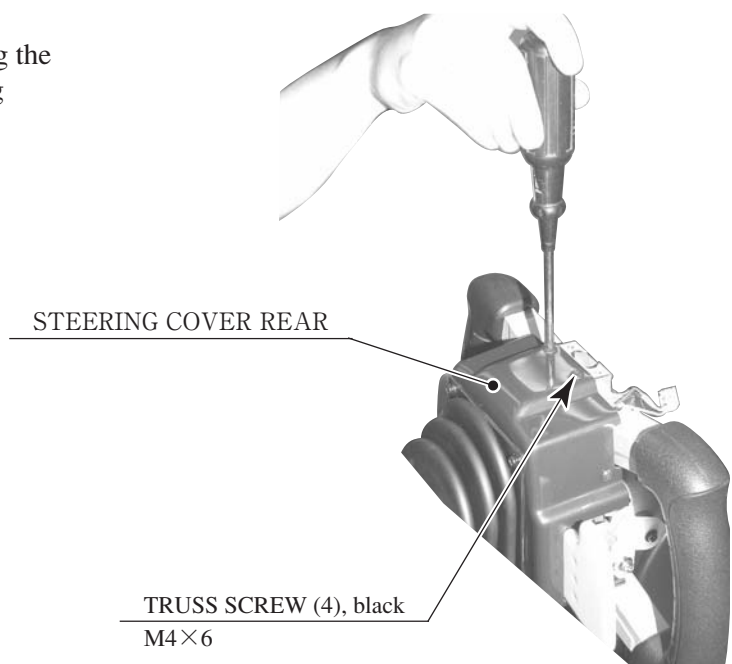
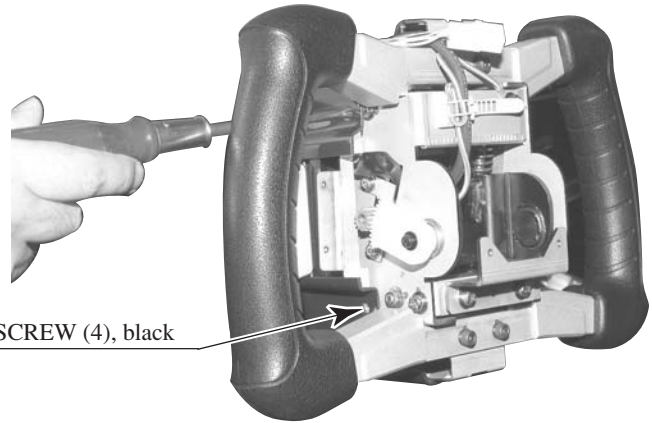

PHOTO 11. 1 e

- ⑦ Remove the 4 truss screws holding the left and right sides of the rear steering cover in place.



TRUSS SCREW (4), black
M4×6

PHOTO 11.1 f

- ⑧ Push the rear steering cover towards the interior of the machine, pressing down on the accordion-fold behind the cover. The Y-axis VR should now be visible inside the cover, on the left side when facing the monitor.

NOTE: The steering unit has been removed in this photograph for better visibility. It is not necessary to remove the steering unit when performing the actual operation.

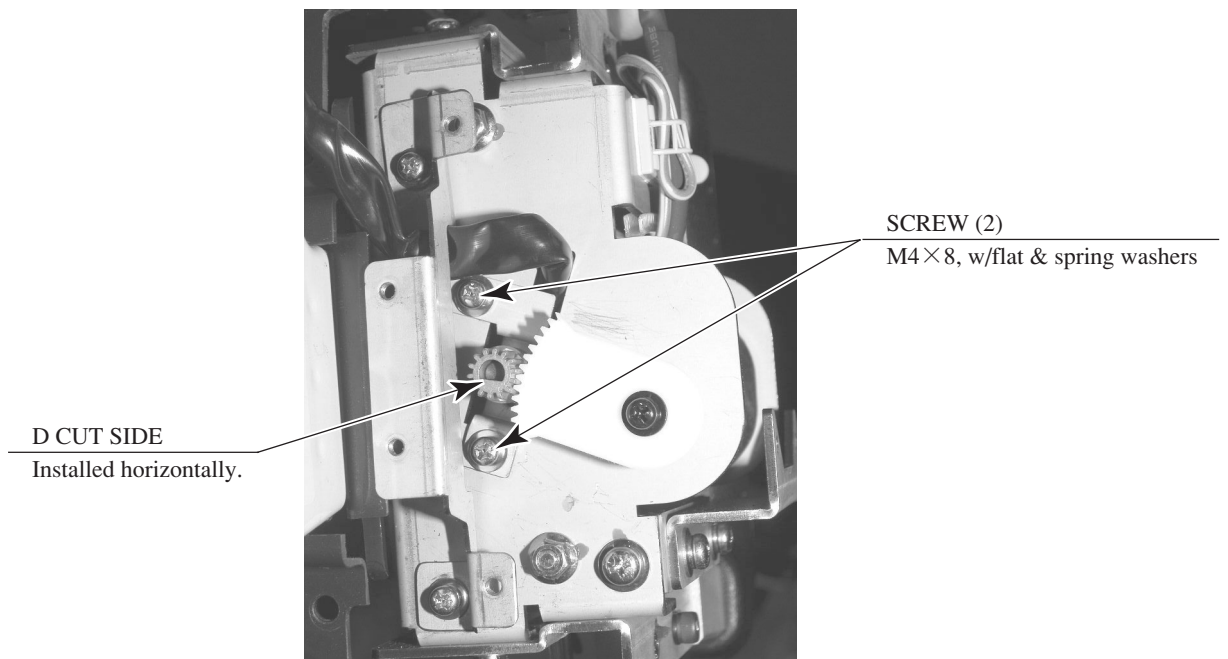

D CUT SIDE
Installed horizontally.

SCREW (2)
M4×8, w/flat & spring washers

PHOTO 11.1 g

- ⑨ Loosen the 2 screws holding the variable resistor bracket in place, move the variable resistor bracket, and adjust the gear engagement for angle and positioning.

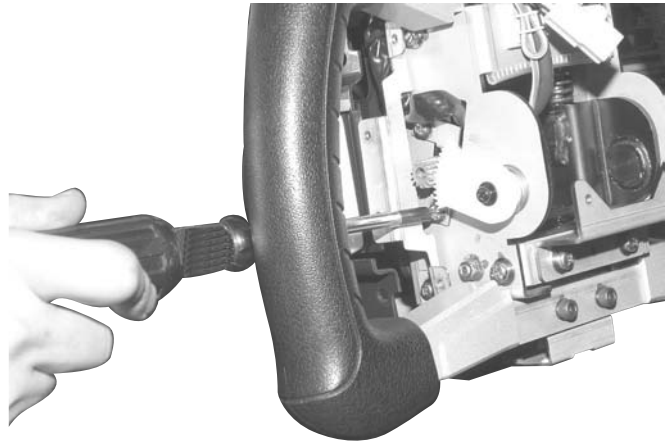

PHOTO 11. 1 h

- ⑩ Engage and secure the gear at such an angle that the D-cut side of the VR axle is horizontal and facing downward when the steering unit is not tilted.
- ⑪ Manipulate the steering unit and make sure the gear is turning smoothly.
- ⑫ Repeat the above steps in reverse to replace the front and rear steering covers. Take care not to pinch the wires or overtighten screws.
Note that the screws used to secure the left and right sides of the front steering cover have different dimensions from the others. Check the screw sizes before installing them.
- ⑬ Adjust the variable resistor settings on the Volume Settings screen. (see 10-3G.)
- ⑭ Check to make sure the "STEERING Y" value on the Input Test screen is within the range $78H \pm 8H$.

REPLACEMENT PROCEDURE

- ① Perform steps ① through ⑦ under "Adjustment Procedure" to detach the front and rear steering covers.
- ② Unplug the Y-axis VR wire connectors and unfasten the harness lug holding the wiring in place.

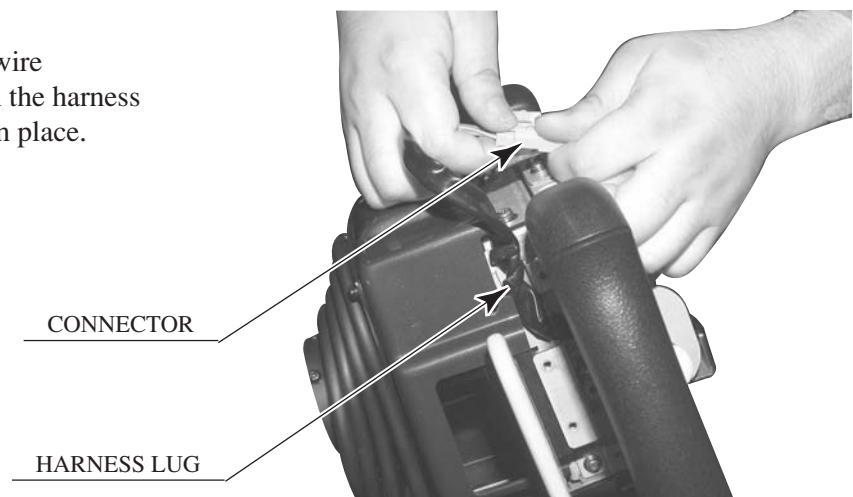

PHOTO 11. 1 i

- ③ Remove the 2 screws holding the variable resistor bracket in place and then remove the Y-axis VR, bracket and all.

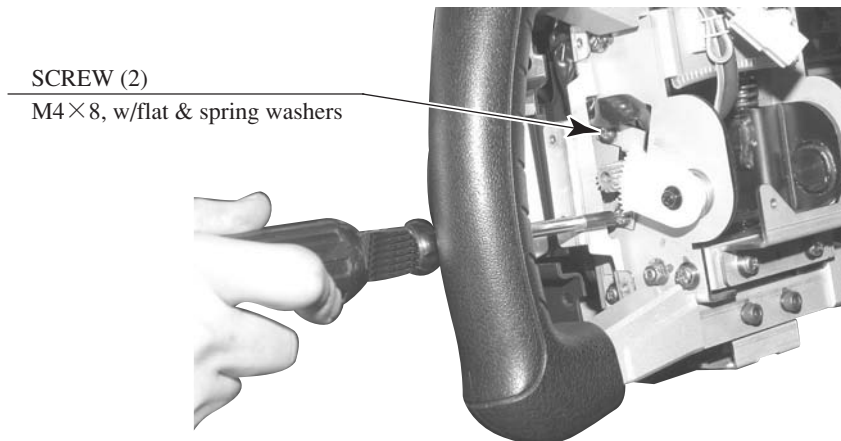

PHOTO 11. 1 j

- ④ Loosen the 2 hexagon socket screws holding the gear in place and disengage the gear from the VR axle.

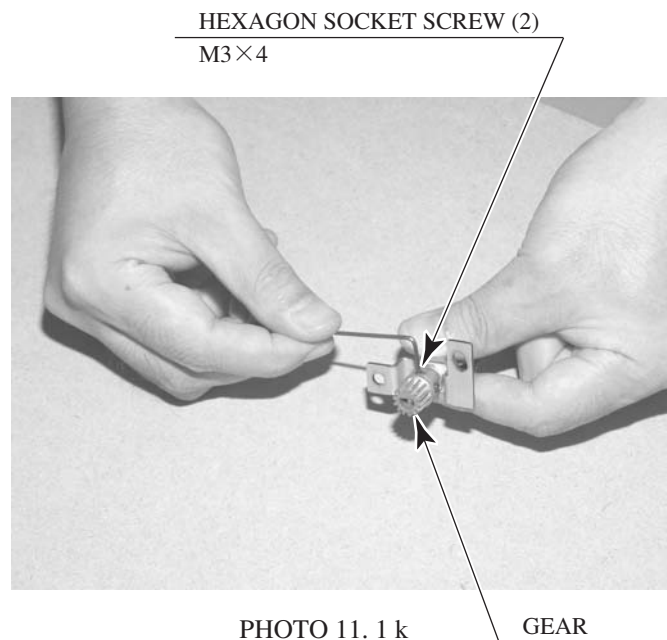

PHOTO 11. 1 k

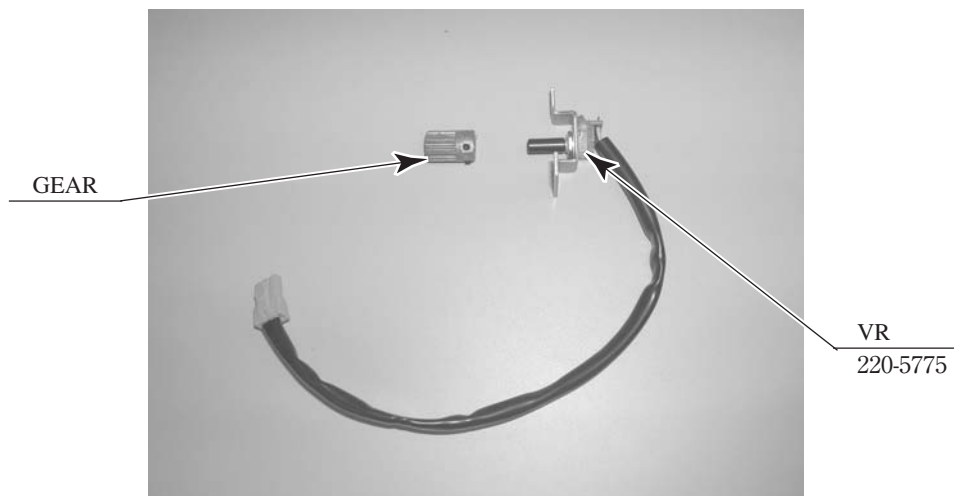

PHOTO 11. 1 l

- ⑤ The wires connected to the old VR can be reused for the new VR. Use the soldering iron to melt the welds and remove the wires from the VR.
- ⑥ Solder the wires to the new VR. Check the wiring diagram to make sure there are no mistakes in the wiring.

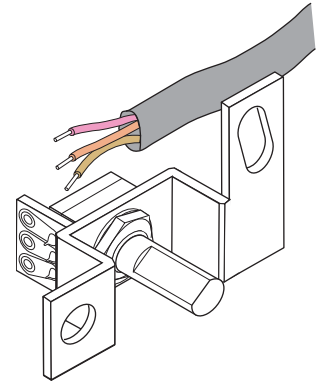

FIG. 11. 1

- ⑦ Attach the gear to the new VR.
- ⑧ Install the new Y-axis VR. Engage and secure the gear at such an angle that the D-cut side of the VR axle is level and facing downward when the steering unit is not being tilted.
- ⑨ Manipulate the steering unit make sure the gear is turning smoothly.
- ⑩ Plug in the wiring connectors and secure the wires with the harness lug.
- ⑪ Repeat the above steps in reverse to replace the front and rear steering covers. Take care not to pinch the wires or overtighten screws.
Note that the screws used to secure the left and right sides of the front steering cover have different dimensions from the others. Check the screw sizes before installing them.
- ⑫ Adjust the variable resistor settings on the Volume Settings screen. (see 10-3G.)
- ⑬ Check to make sure the "STEERING Y" value on the Input Test screen is within the range $78H \pm 8H$.

11 — 2 REPLACING THE MICROSWITCHES

Movement in the steering unit's paddle levers is detected by 2 microswitches on the bottom of the interior of the steering cover. Follow the steps listed below to replace or adjust the position of these switches.

Note that each of the 2 microswitches on the bottom of the steering unit is linked to the paddle on the OPPOSITE side in the "PADDLE LEFT/RIGHT" test on the Input Test screen; that is, the microswitch on the right controls the "PADDLE LEFT" value, and vice-versa. Check to make sure the switch being replaced or adjusted is the correct one.

The following tools and instruments are required for the following operations:

- 3mm diameter hexagonal screwdriver or wrench
- M4-size Phillips screwdriver
- M3-size Phillips screwdriver
- Nippers
- Cutters
- Soldering iron
- Industrial dryer

ADJUSTMENT PROCEDURE

- ① Perform steps 1 through 7 for adjusting the Y-axis VR to remove the front steering cover and detach the rear steering cover (see 11-1).
- ② Loosen the 2 screws securing the SW ADJUST plate on which the microswitch to be adjusted is installed, and then move the SW ADJUST plate to adjust it. Do not loosen the screws on the side the microswitch is installed on.

SCREW (2)
M3×6, w/flat & spring washers

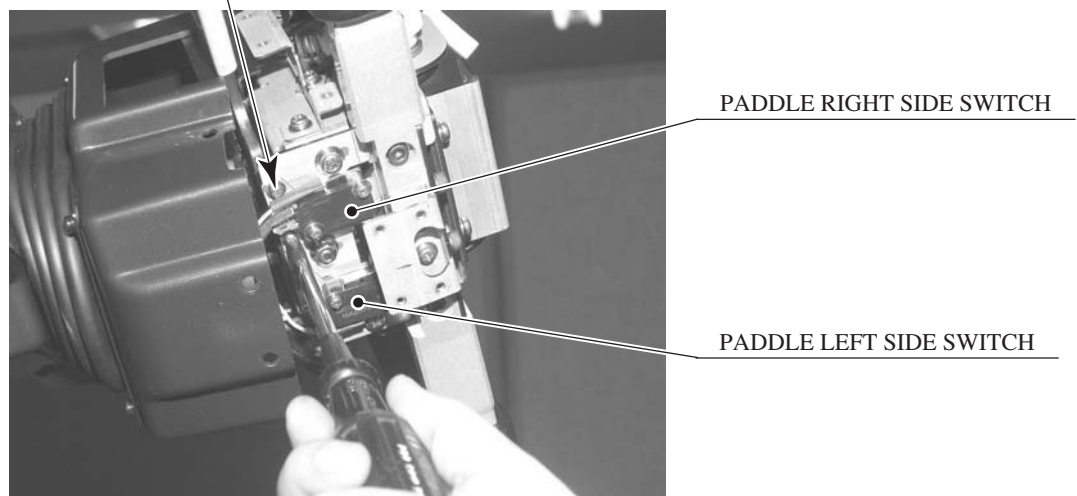

PHOTO 11. 2 a

- ③ Adjust the switch so that the roller on its actuator terminal touches the pin that interlocks with the paddle lever when the lever is not being manipulated.
- ④ Tighten the 2 screws.
- ⑤ Manipulate the paddle lever to make sure the microswitches are turning on and off properly. Listen for a clicking sound. Also, make sure that the switch does not adhere to the actuator itself when turned on.
- ⑥ Replace the front and rear steering covers. Take care not to pinch the wires or overtighten the screws.
Note that the screws used to secure the left and right sides of the front steering cover have different dimensions from the others. Check the dimensions of the screws before installing them.
- ⑦ On the Input Test screen, check to make sure that the microswitches turn on and off consistently when the paddle levers are manipulated (see 10-3B).

REPLACEMENT PROCEDURE

- ① Remove the front steering cover and detach the rear steering cover (see 11-1).
- ② Unplug the wire connectors from the microswitch and unfasten the harness lug holding the wires in place.

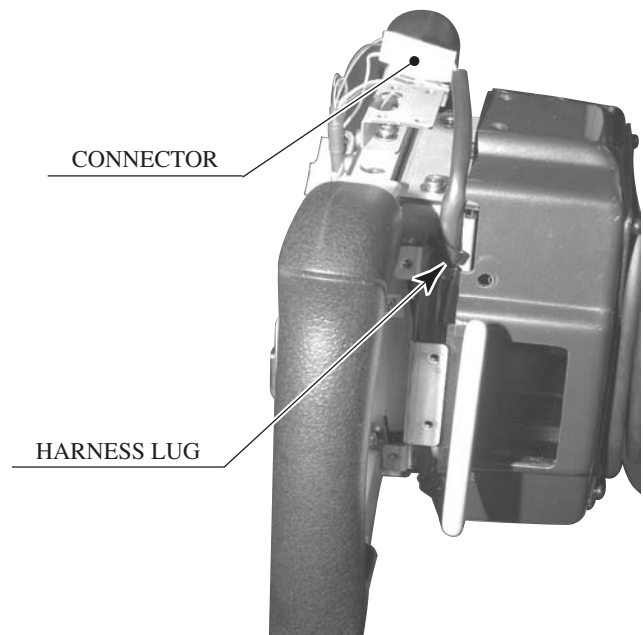

PHOTO 11. 2 b

- ③ Remove the 2 screws holding the SW ADJUST plate in place and then remove the microswitch together with the SW ADJUST plate.

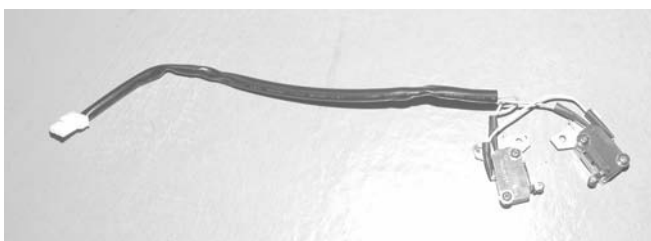
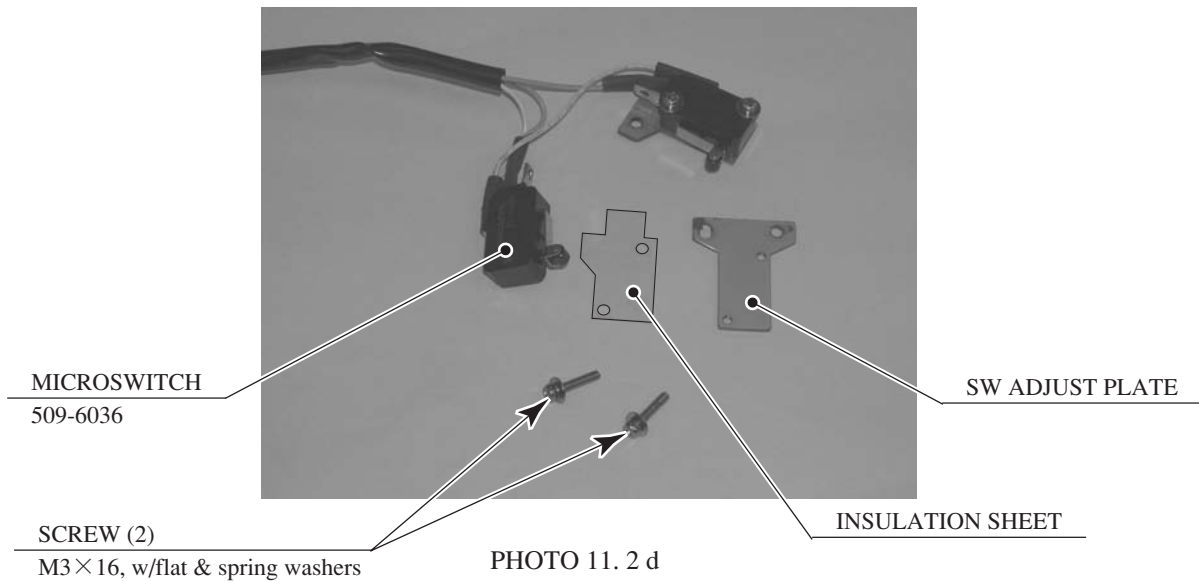

PHOTO 11. 2 c

- ④ Remove the 2 screws securing the microswitch to be replaced and then remove the SW ADJUST plate and the transparent insulation sheet.



- ⑤ The wires connected to the old microswitch can be reused for the new microswitch. Remove the heat contraction tube covering the soldered areas, use the soldering iron to melt the solder, and remove the wires from the microswitch.
- ⑥ Solder the wires to the new microswitch. Check the wiring diagram to make sure there are no mistakes in the wiring. In addition, use a heat contraction tube or other protection to prevent short-circuiting.
- ⑦ Attach the SW ADJUST plate and the insulation sheet to the new microswitch and secure them with 2 screws. Be sure to insert the insulation sheet between the switch and the plate.
- ⑧ Install the SW ADJUST plate with the new microswitch in the bottom of the steering unit. Adjust the position of the plate so that the roller on the microswitch's actuator terminal touches the pin that interlocks with the paddle lever when the lever is not being manipulated, and secure it with 2 screws.
- ⑨ Connect the wire connectors and secure the wires with a harness lug.
- ⑩ Manipulate the paddle lever to make sure the microswitches are turning on and off properly. Listen for a clicking sound. Also, make sure that the switch does not adhere to the actuator itself when turned on.
- ⑪ Replace the front and rear steering covers. Take care not to pinch the wires or overtighten the screws.
Note that the screws used to secure the left and right sides of the front steering cover have different dimensions from the others. Check the dimensions of the screws before installing them.
- ⑫ On the Input Test screen, check to make sure that the microswitches turn on and off consistently when the paddle levers are manipulated (see 10-3B).

11 — 3 GREASING



- Be sure to use the designated type of grease. If a non-designated type of grease is used, components may break.
- Do not apply grease to any part of the machine other than those parts specifically indicated. Doing so may result in malfunctioning and/or deterioration of parts.
- The period for greasing specified herein is a standard. Apply greasing to the specified portions as occasion arises.

Use spray grease once every three months to grease up the gear mesh portion of the constituent parts.

Use "Grease Mate" (part number 090-0066) for the spray grease.

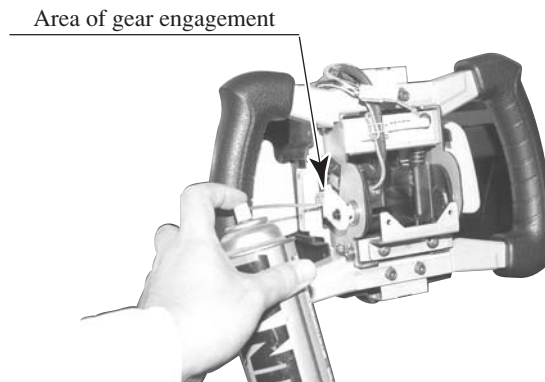

PHOTO 11. 3

12. MAINTAINING THE BASE INTERIOR



- In order to prevent an electric shock and short circuit, be sure to turn power off before performing work by touching the interior parts of the product.
- Be careful not to damage the wires. Damaged wires may cause electric shock or short circuit or present a fire risk.
- Do not touch undesignated places. Touching places not designated can cause electric shock or short circuit.
- This work should be performed by the site maintenance individual or other skilled professional. Performing work by non-technical personnel can cause electric shock hazard.
- Do not perform work other than those specified in this Manual in order to prevent accidents during performing work and operation after performing work. Performing work not specified in this Manual may require special training for this product. If performing work other than those stated in this manual is required for repair, contact the offices herein stated in this manual or where you purchased the product from and ask for repair or inquire how to repair.
- Be very careful when soldering. Handling a soldering iron carelessly may result in a fire or a burn.
- Be extremely careful when heating the heat-shrinkable tube. Failure to do so may result in a fire or burns.
- After making adjustments or replacements, check the surrounding area before turning the power on. The machine will automatically go through initialization after the power is turned on, and any persons in the vicinity may be struck and/or knocked down by the moving seat.
- Requests for maintenance of the seat motion mechanism should be directed to the office listed in this manual or your retailer. Attempts to perform maintenance by persons other than specially trained technicians may result in injury to the party performing the maintenance and/or to players during product operation.
- Be careful not to trap hands or fingers inside mechanical parts. Doing so may result in broken bones and other serious injury.



When adjusting or changing the variable resistor, set the variable resistor values on the Volume Settings screen and check the values on the Input Test screen in Test mode.

If directional control response is less than ideal and adjusting the settings on the Volume Settings screen in Test mode has no effect, the problem is most likely due to an incorrectly engaged gear in the steering VR or a broken variable resistor.

Follow the steps listed below to correct the gear engagement or replace the variable resistor. In the case of faulty movement in the seat, the source of the problem is most likely an incorrectly engaged gear or broken variable resistor in the Roll VR.

The steering VR and Roll VR are both located on the AC unit side of the base interior.

12 — 1 ADJUSTING AND REPLACING THE STEERING VR

The variable resistor that detects steering in the directional controls is called the X-axis steering VR. There are VR units located on the top and bottom of the base interior, just inside the front lid. The steering VR unit is the one on top.

In this machine, the VR will not be damaged as long as its axle rotates within its range of motion when the steering unit is turned all the way to the left and right. Secure the VR so that its axle points in the indicated direction and the gear is properly engaged when the steering unit is in the straight position.

The following tools and instruments are required to perform these operations.

- M4-size Phillips screwdriver
- 1.5mm diameter hexagonal screwdriver or wrench
- 11-12mm diameter spanner
- Nippers
- Cutters
- Soldering iron
- Industrial dryer

ADJUSTMENT PROCEDURE

- ① Turn off the power.
- ② Remove the 6 truss screws holding the front lid of the base in place and then remove the lid.

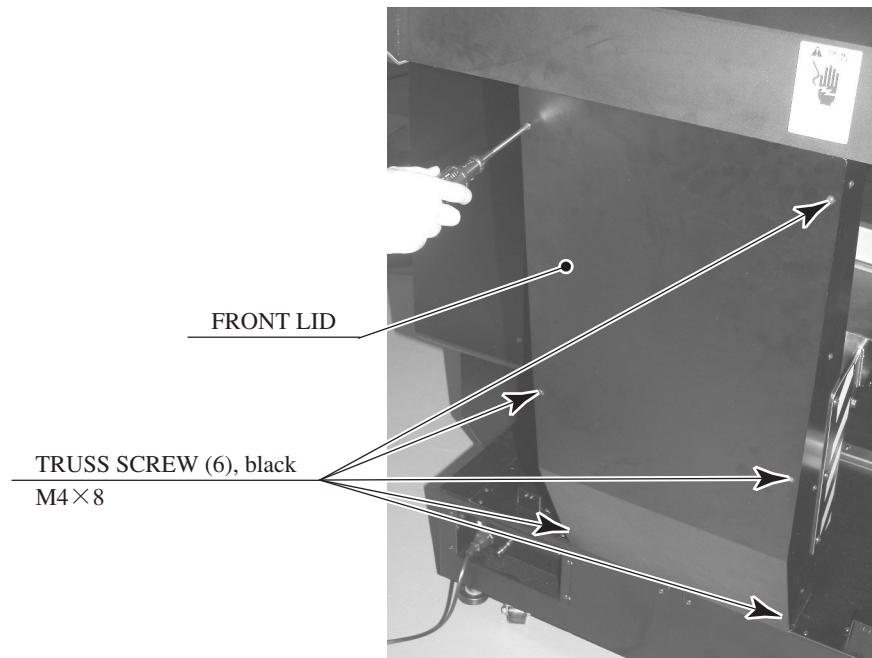

PHOTO 12. 1 a

- ③ Loosen the 2 screws holding the steering VR bracket in place and disengage the gear.

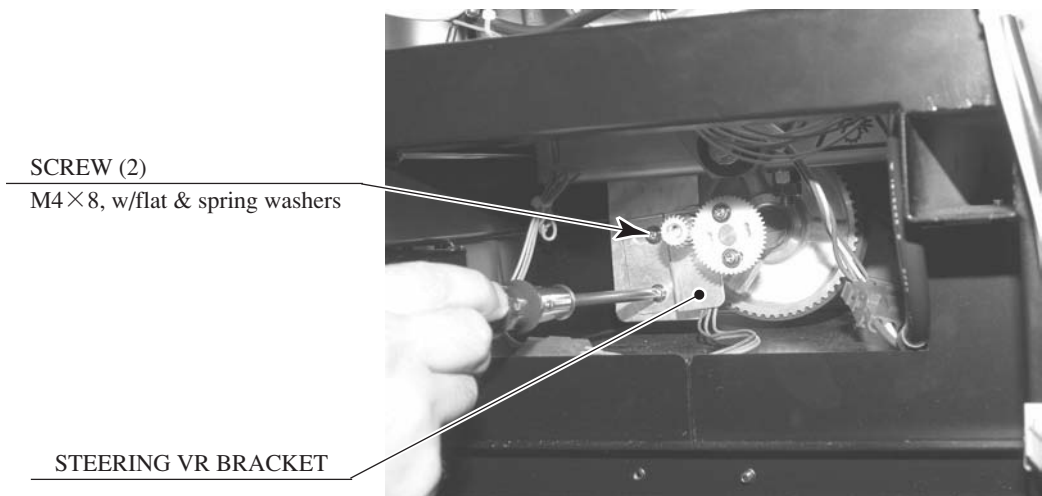
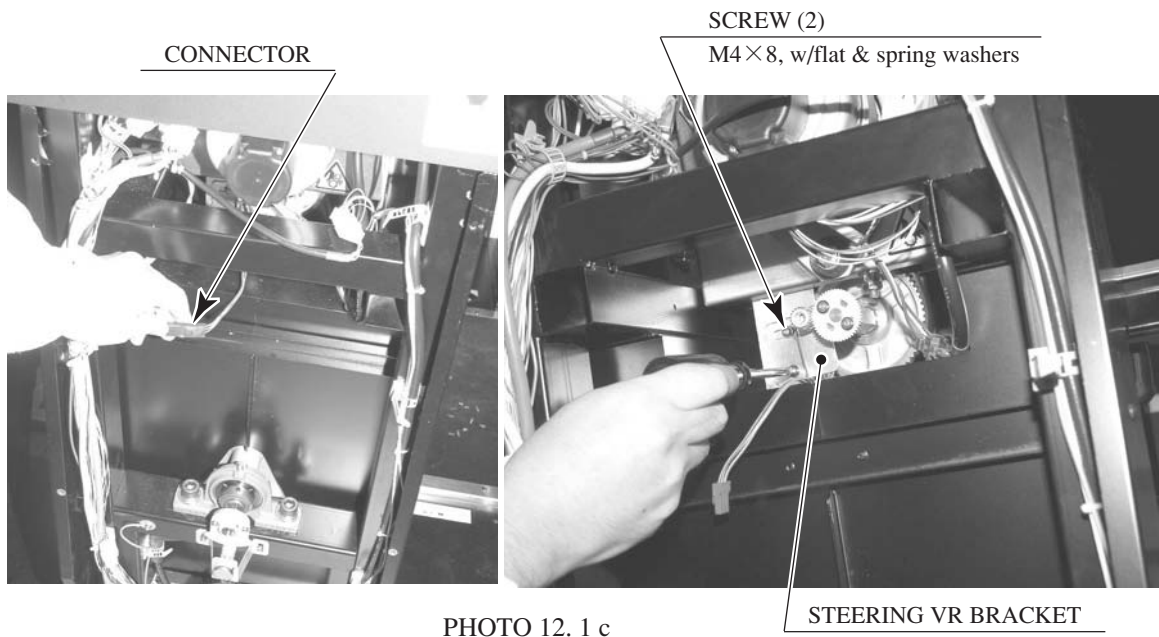

PHOTO 12.1 b

- ④ Engage the gear so that the D-cut side of the VR axle is level and facing downward when the steering unit is in the straight position (see Figure 12-1).
- ⑤ Tighten the 2 screws holding the bracket in place.
- ⑥ Adjust the variable resistor settings on the Volume Settings screen (see 10-3G).
- ⑦ Check to make sure the "STEERING X" value on the Input Test screen is within the range $80H \pm 8H$ when the steering unit is in the straight position.

REPLACEMENT PROCEDURE

- ① Turn off the power.
- ② Remove the 6 truss screws holding the front lid of the base in place and then remove the lid.
- ③ Remove the steering VR unit. Unplug the connectors and remove the 2 screws holding the steering VR bracket in place.



- ④ Loosen the 2 socket screws holding the gear in place and disengage the gear from the VR axle.

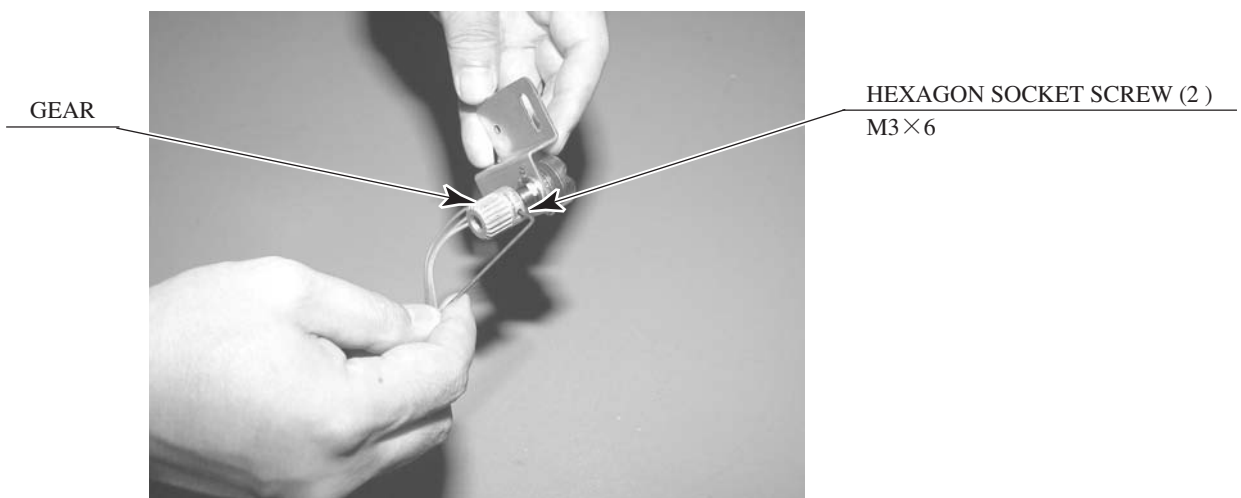

- ⑤ Remove the nut securing the steering VR bracket and then remove the VR from the bracket.

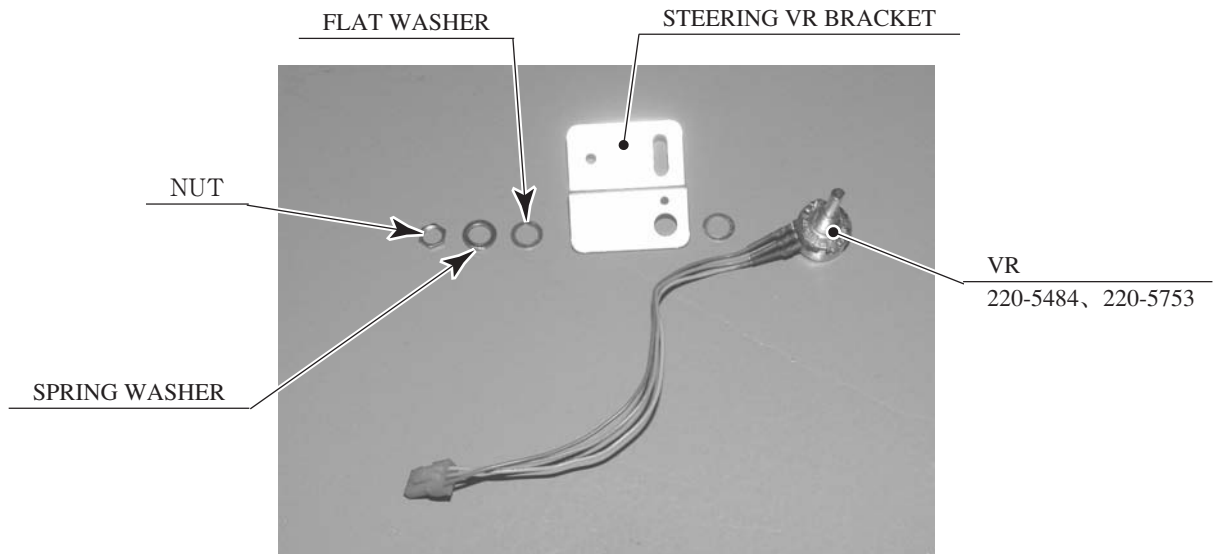

PHOTO 12.1 e

- ⑥ The wires connected to the old VR can be reused for the new VR. Remove the heat contraction tube covering the soldered areas, use the soldering iron to melt the solder, and remove the wires from the VR.
- ⑦ Solder the wires to the new VR. Check the wiring diagram to make sure there are no mistakes in the wiring. In addition, use a heat contraction tube or other device to prevent short-circuiting.
- ⑧ Install the new VR and the gear in the steering VR bracket.
- ⑨ Install the steering VR unit.
Engage the gear so that the D-cut side of the VR axle is level and facing downward when the steering unit is in the straight position, and secure it with 2 screws.

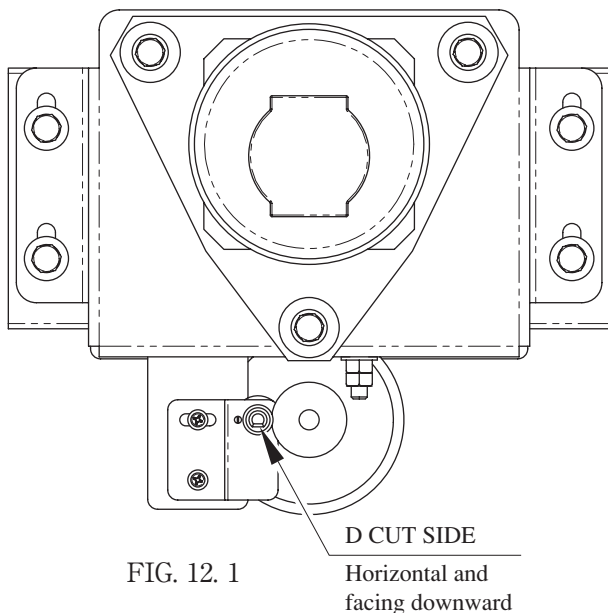

FIG. 12.1

Horizontal and facing downward

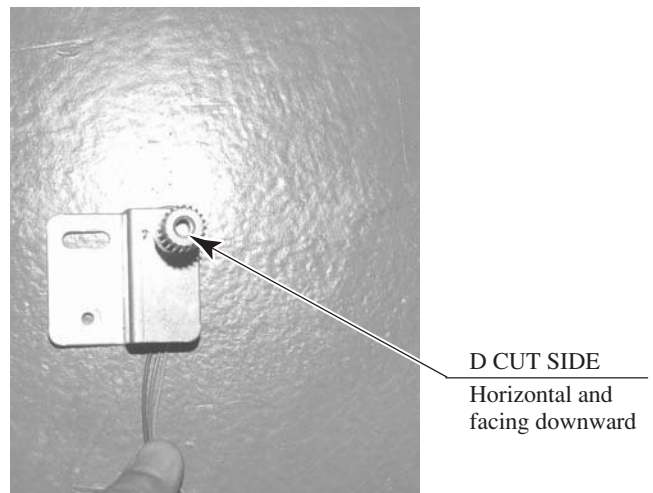

PHOTO 12.1 f

- ⑩ Plug in the connectors.
- ⑪ Adjust the variable resistor settings on the Volume Settings screen (see 10-3G).
- ⑫ Check to make sure the "STEERING X" value on the Input Test screen is within the range $80H \pm 8H$ when the steering unit is in the straight position.

12 — 2 ADJUSTING AND REPLACING THE ROLL VR

The variable resistor that detects the degree of tilt in the seat is called the roll VR. There are VR units located on the top and bottom of the base interior, just inside the front lid. The Roll VR is the one on the bottom.

In this machine, no damage should occur to the VR as long as its axle rotates within its range of motion when the seat swings all the way to the left and right. Secure the VR so that its axle points in the indicated direction and the gear is properly engaged when the seat is level.

The following tools and instruments are required to perform these operations:

- M4-size Phillips screwdriver
- 1.5mm diameter hexagonal screwdriver or wrench
- 11-12mm diameter spanner
- Nippers
- Cutters
- Soldering iron
- Industrial dryer

ADJUSTMENT PROCEDURE

- ① Turn of the power
- ② Remove the 6 truss screws holding the front lid of the base in place and then remove the lid.
- ③ Remove the 2 screws holding the Roll VR bracket in place and then remove the Roll VR unit.

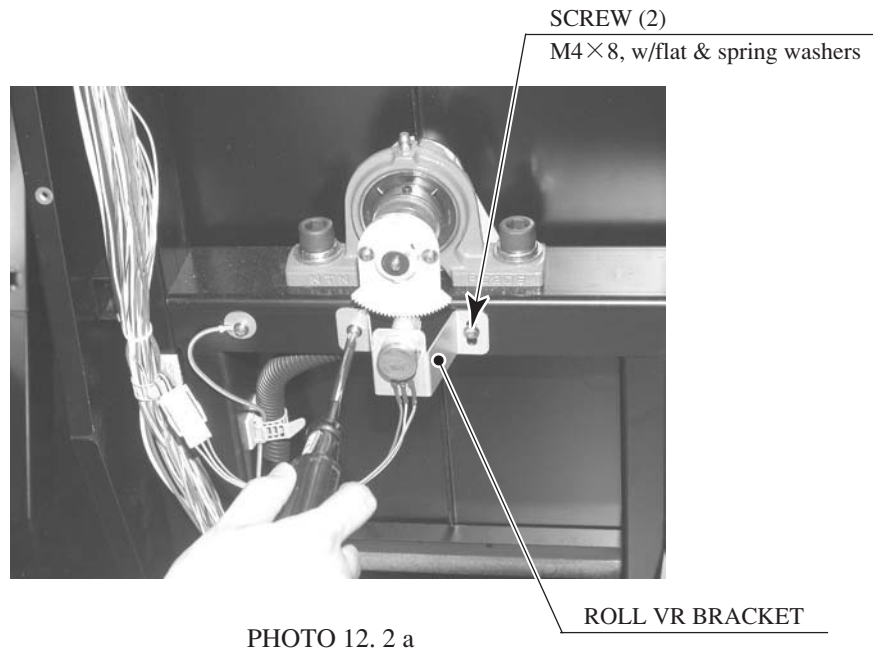

- ④ Rotate the gear so that the D-cut side of the VR axle is horizontal and facing downward.
- ⑤ Insert the VR unit without causing the gear to rotate and secure it with 2 screws. The gear engagement should also be adjusted at this time.
- ⑥ Check to make sure the "SEAT MOTION" value on the Input Test screen is within the range $80H \pm 8H$ when the seat is level. If the value is outside this range, adjust the VR again.

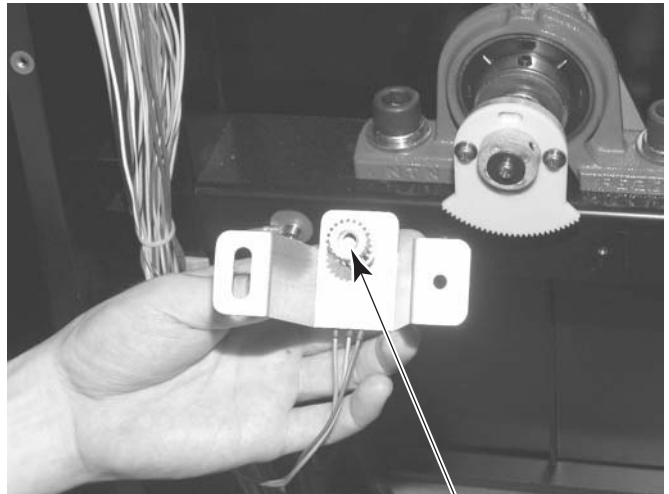
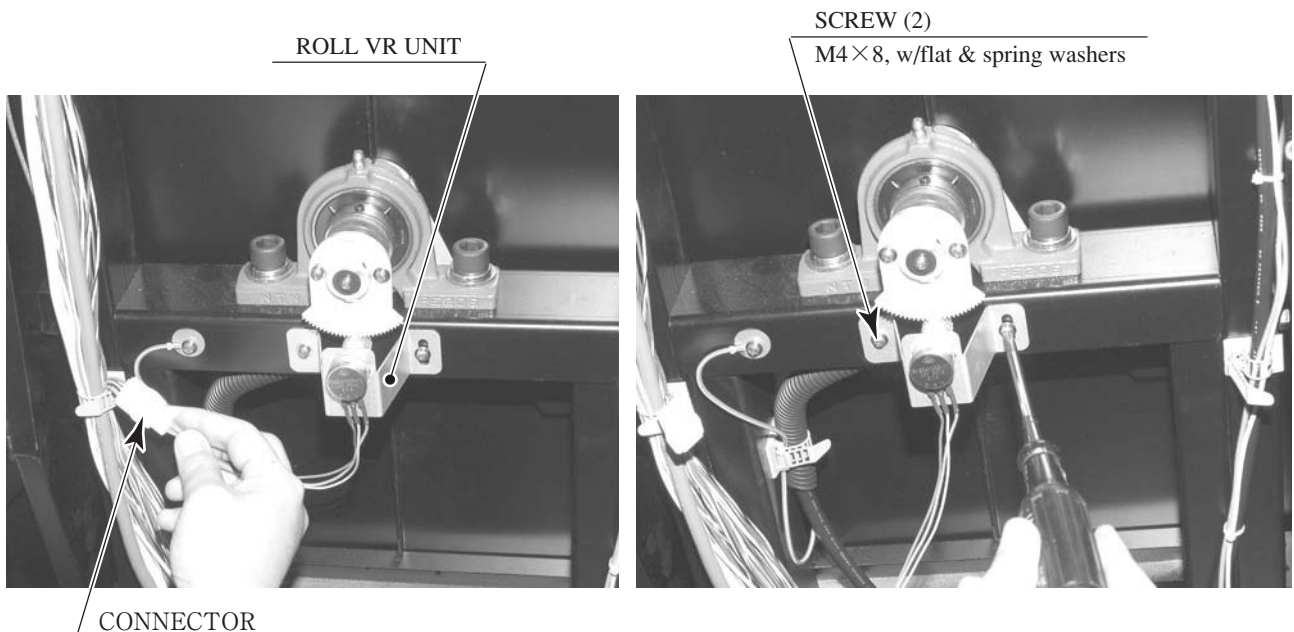

PHOTO 12. 2 b

D CUT SIDE
Horizontal and
facing downward

REPLACEMENT PROCEDURE

- ① Turn off the power.
- ② Remove the 6 truss screws holding the front lid of the base in place and then remove the lid.
- ③ Remove the roll VR unit. Unplug the connectors and remove the 2 screws holding the roll VR bracket in place.



ROLL VR UNIT

SCREW (2)
M4×8, w/flat & spring washers

CONNECTOR

PHOTO 12. 2 c

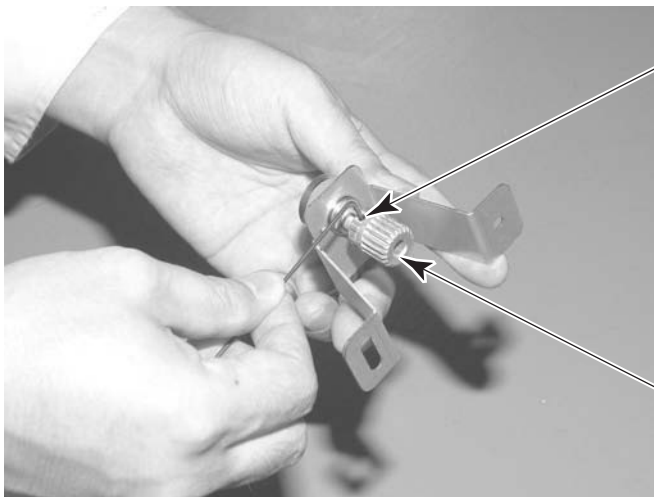

HEXAGON SOCKET SCREW (2)
M3×6

- ④ Loosen the 2 hexagon socket screws holding the gear in place and remove the gear from the VR axle.

GEAR

PHOTO 12. 2 d

- ⑤ Remove the nut securing the roll VR bracket and then remove the VR from the bracket.

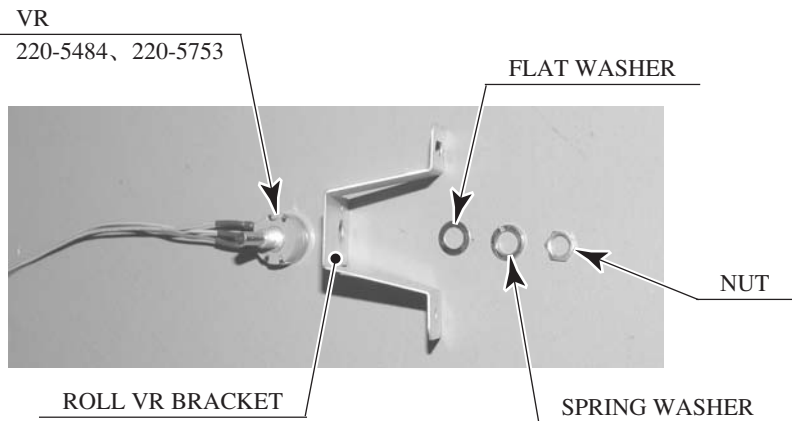

PHOTO 12. 2 e

- ⑥ The wires connected to the old VR can be reused for the new VR. Remove the heat contraction tube covering the soldered areas, use the soldering iron to melt the solder, and remove the wires from the VR.
- ⑦ Solder the wires to the new VR. Check the wiring diagram to make sure there are no mistakes in the wiring. In addition, use a heat contraction tube or other device to prevent short-circuiting.
- ⑧ Install the new VR and the gear in the Roll VR bracket.
- ⑨ Rotate the gear so that the D-cut side of the VR axle is horizontal and facing downward.

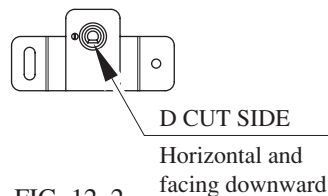

FIG. 12. 2

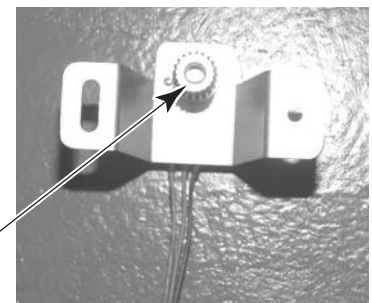

PHOTO 12. 2 f

- ⑩ Check to make sure the seat is level.
- ⑪ Install the Roll VR unit. Insert the Roll VR unit without causing the gear to rotate and secure it with 2 screws.
The gear engagement should also be adjusted at this time.
- ⑫ Check to make sure the "SEAT MOTION" value on the Input Test screen is within the range $80H \pm 8H$ when the seat is level. If the value is outside this range, adjust the VR again.



- Be sure to use the designated type of grease. If a non-designated type grease is used, components may break.
- Do not apply grease to any part of the machine other than those parts specifically indicated. Doing so may result in malfunctioning and/or deterioration of parts.
- The period for greasing specified herein is a standard. Apply greasing to the specified portions as occasion arises.

Use spray grease once every three months to grease up the gear mesh portion of the constituent parts.

Use "Grease Mate" (part number 090-0066) for the spray grease.

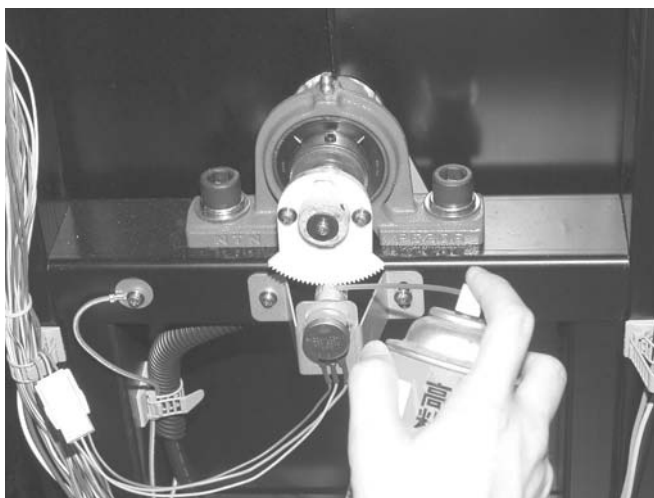
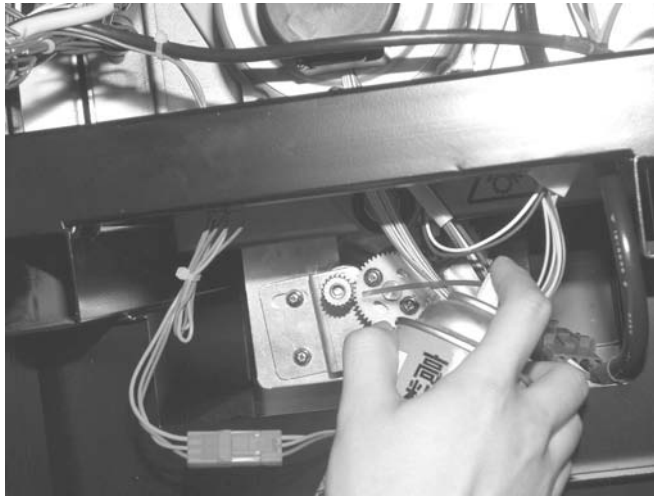

PHOTO 12. 3



- If the seat motion mechanism begins to malfunction, immediately cease operation, turn off the power, unplug the power cord, and contact the office listed in this manual or your retailer. Continuing to operate the machine without resolving the problem may result in serious accidents such as electric shock, short circuits, or fire, and/or cause the machine to tip over.
- Requests for maintenance of the seat motion mechanism should be directed to the office listed in this manual or your retailer. Attempts to perform maintenance by persons other than specially trained technicians may result in injury to the party performing the maintenance and/or to players during product operation.
- Contact the office listed In this manual or the product's point of purchase once a year for regular maintenance of the seat motion mechanism. Failure to service the mechanism may result in sudden breakdown and accidents.

Contact the office listed In this manual or the product's point of purchase once a year for regular maintenance on the seat motion (rolling) mechanism. Scheduling the maintenance to coincide with cleaning of the machine's interior is recommended.

The following is a general outline of the maintenance process. Special tools are required.

- ① Turn off the power.
- ② Remove the 5 truss screws securing the machinery cover on the rear of the base.

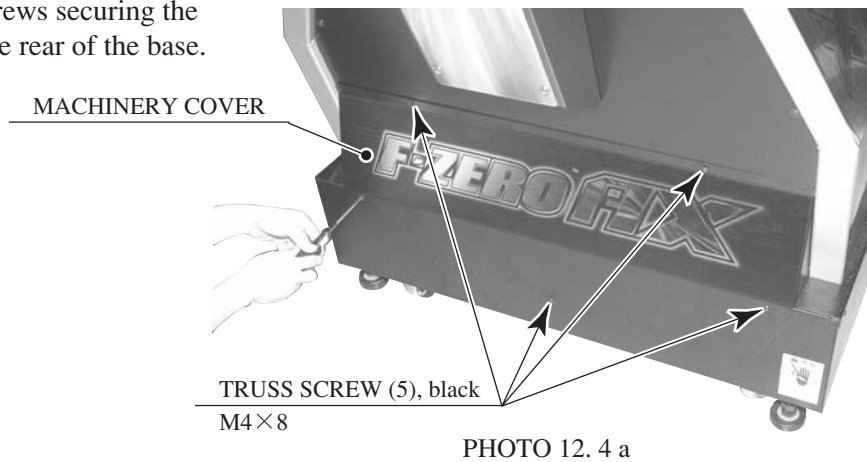

- ③ Remove the machinery cover from the rear of the base.



④ Removing the machinery cover will reveal the seat motion mechanism. The following maintenance tasks will now be performed:

- Check motion
- Check fasteners
- Tighten fasteners
- Grease-up
- Adjust belt tension
- Replace worn-out parts

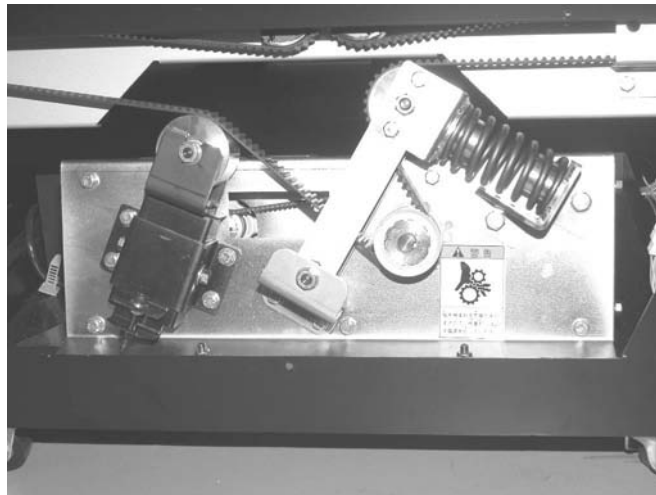

PHORO 12. 4 c

13. ACCELERATOR & BRAKE



- Before starting to work, ensure that the Power SW is OFF. Failure to observe this can cause electric shock or short circuit.
- Use care so as not to damage wirings. Damaged wiring can cause electric shock or short circuit.
- Do not touch undesignated places. Touching places not designated can cause electric shock or short circuit.
- This work should be performed by the site maintenance individual or other skilled professional. Performing work by non-technical personnel can cause electric shock hazard.
- When performing work such as parts replacement other than those specified in this manual, be sure to contact where you purchased the product from. Confirm the work procedures and obtain precautions from where you purchased the product prior to performing work. Inappropriate parts replacement and/or installation with erroneous adjustment can cause an overload or the parts to come into contact, resulting in an electric shock, a short circuit, and a fire.



Be sure to perform volume's move value setting in the Volume Setting in the Test Mode after replacing or adjusting the Volume. (See 10-3G.)

If Accel. and Brake operation is not satisfactory, adjustment of volume installation position or volume replacement is needed. Also, be sure to apply greasing to the gear mesh portion once every 3 months.

13 — 1 ADJUSTING OR REPLACING THE VOLUME

The following tools are required for the operations below: Phillips screwdrivers for M4 and M5. The appropriate value for both ACCEL. Volume and Brake Volume is under 30H when released and over C0H when stepped on. Check Volume values in the TEST mode. Since work is performed inside the energized cabinet, be very careful so as not to touch undesignated places. Touching places not specified can cause electric shock or short circuit.

ADJUSTMENT PROCEDURE

- ① Take out the 2 truss screws and remove the Front Cover from the Accel. & Brake Unit (FIG. 13. 1 a).

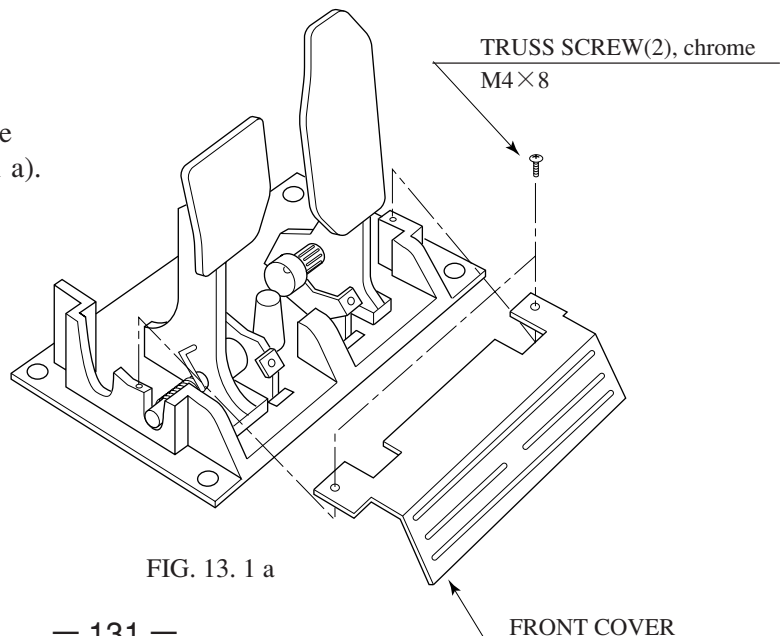

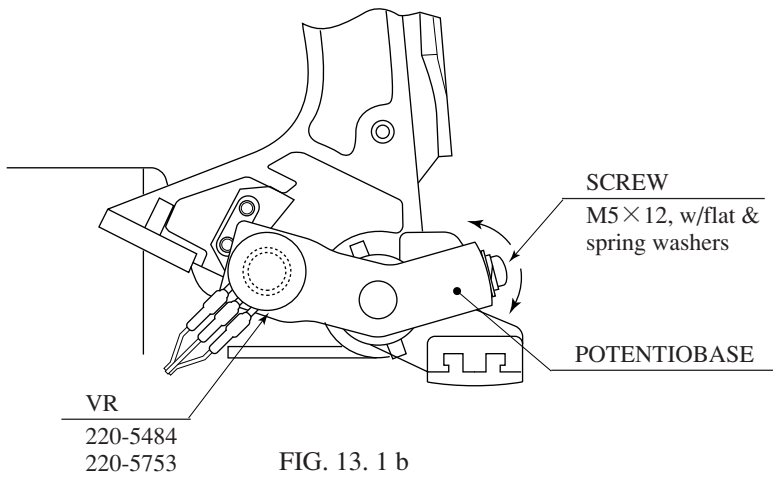

- ② Loosen the screw which secure the Potentiobase, and adjust the Volume value by moving the Base. (FIG. 13. 1 b)
- ③ Secure the Potentiobase.
- ④ Perform volume setting in the volume setting mode. (See 10-3G.)

REPLACEMENT PROCEDURE

- ① Turn the power off.
- ② Take out the 2 screws and remove the Potentiocover (FIG. 13. 1 c).
- ③ Disconnect the connector of the volume to be replaced.
- ④ Remove the screw which secures the Potentiobase (FIG. 13. 1 b).
- ⑤ Remove the Potentiobase together with the volume as is attached. (FIG. 13. 1 c)
- ⑥ Remove the base and the gear to replace the volume.
- ⑦ Adjust the volume as per the previous page after replacing.

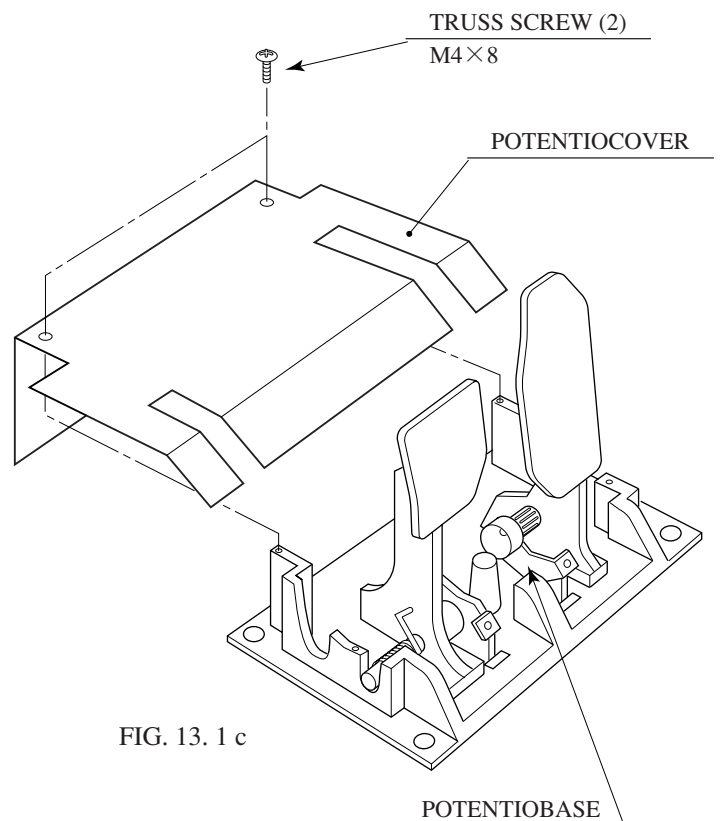

13 — 2 GREASING



Be sure to use the designated grease. Using undesignated grease can cause parts damage.

Use spray grease once every three months to grease up the Spring and gear mesh portion. For spray greasing, use GREASE MATE (PART No. 090-0066).

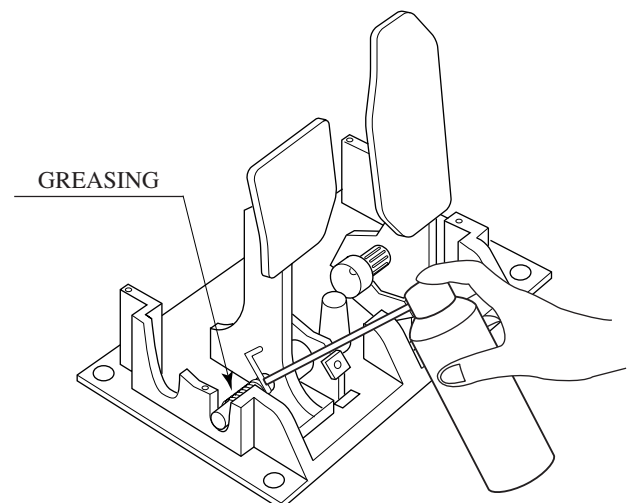

14. COIN SELECTOR

HANDLING THE COIN JAM

If the coin is not rejected when the REJECT button is pressed, open the coin chute door and open the selector gate. After removing the jammed coin, put a normal coin in and check to see that the selector correctly functions.

CLEANING THE COIN SELECTOR



- Remove and clean smears by using a soft cloth dipped in water or diluted chemical detergent and then squeezed dry.
- Never apply machine oil, etc. to the Coin Selector.
- After cleaning the Coin Selector, insert a regular coin in the normal working status and ensure that the Selector correctly functions.

The coin selector should be cleaned once every 3 months. When cleaning, follow the procedure below:

- ① Turn the power for the machine OFF. Open the coin chute door.
- ② Remove the coin selector from the coin chute door.
- ③ Open the gate and dust off by using a soft brush (made of wool, etc.).
- ④ Remove and clean smears by using a soft cloth dipped in water or diluted chemical detergent and then squeezed dry.
- ⑤ Remove the CRADLE.
When removing the retaining ring (E ring), be very careful so as not to bend the rotary shaft.
- ⑥ Remove stain from the rotary shaft and shaft receiving portions by wiping off with a soft cloth, etc.
- ⑦ After wiping off as per ⑥ above, further apply a dry cloth, etc. to cause the coin selector to dry completely.

COIN INSERTION TEST

Once every month, when performing the Coin SW Test, simultaneously check the following:

- Does the Coin Meter count satisfactorily?
- Does the coin drop into the Cashbox correctly?
- Is the coin rejected when inserted while keeping the Reject Button pressed down?

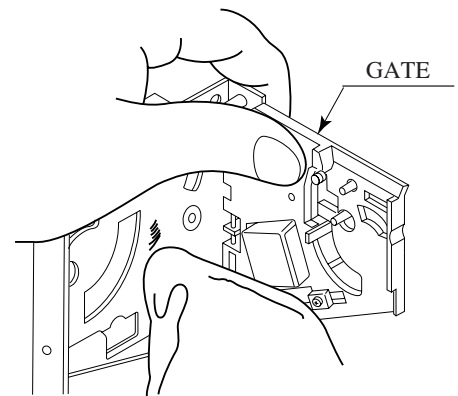

FIG. 14 a

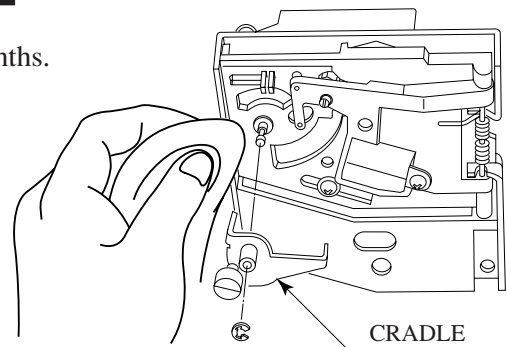

FIG. 14 b

Insert a coin while keeping the Reject Button pressed down and check if it is rejected.

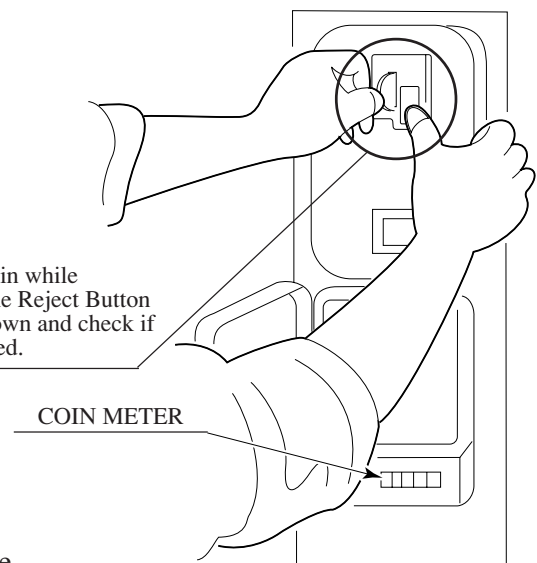

FIG. 14 c

15. MONITOR

15 - 1 CAUTIONS AND WARNINGS CONCERNING THE SAFETY FOR HANDLING THE MONITORS

Before handling the monitors, be sure to read the following explanations and comply with the caution/warning instructions given below. Note that the caution/warning symbol marks and letters are used in the instructions.



WARNING

Indicates that handling the monitors erroneously by disregarding this warning may cause a potentially hazardous situation, which could result in death or serious injury.



CAUTION

Indicates that handling the monitors by disregarding this caution may cause a potentially hazardous situation, which could result in personal injury and or material damage.



Indicates that access to a specific part of the equipment is forbidden.



Indicates the instruction to disconnect a power connector or to unplug.



WARNING

- When performing such work as installing and removing the monitor, inserting and disconnecting the external connectors to and from monitor interior and the monitor, be sure to disconnect the power connector (plug) before starting the work. Proceeding the work without following this instruction can cause electric shock or malfunctioning.
- Using the monitor by converting it without obtaining a prior permission is not allowed. SEGA shall not be liable for any malfunctioning and accident caused by said conversion.



WARNING

● Primary side and Secondary side

The monitor's circuit which is divided into the Primary side and Secondary side, is electrically isolated. Do not touch the primary side, or do not touch both the primary side and the secondary side simultaneously. Failing to observe the instruction can cause electric shock and this is very dangerous. When making monitor adjustments, use a non-conductive driver and make adjustment without touching any part other than the Adjustment V. R. and knob. Also, be sure not to cause a short-circuit to the Primary side and Secondary side. If short-circuited, it can cause electric shock or malfunctioning, which is very dangerous.

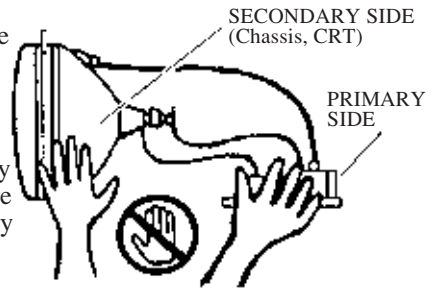

● High-tension Voltage

Some of the parts inside monitor are subject to high-tension voltage in excess of 20,000 volts and very dangerous. Therefore, do not touch the monitor interior. Should soldering & paper wastes, etc. be mixed in the monitor interior, turn the power off so as not to cause malfunctioning or fire hazard.

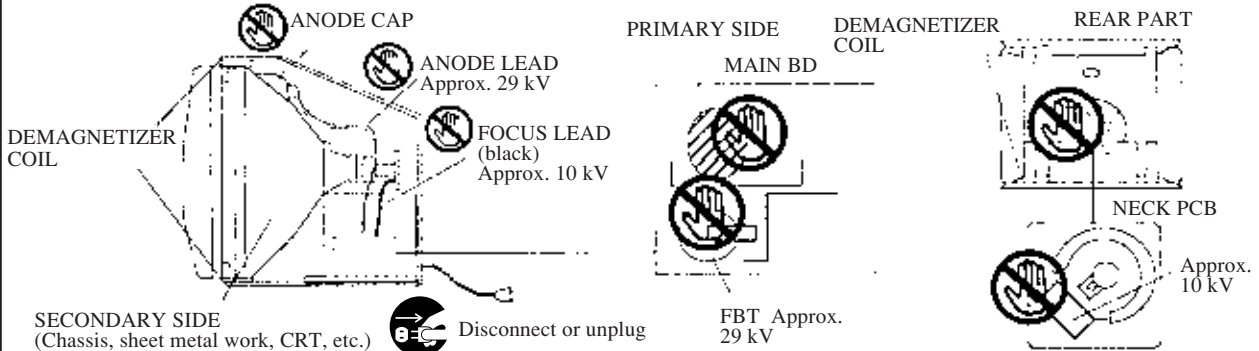

● Connecting the CRT and PCB

For combining the CRT and PCB, use the specified part No. to maintain the status of adjustments made at the factory. The anode of the CRT itself will be accumulatively charged as time elapses, generating high-tension voltage which is very dangerous. The monitor should be used with the Chassis, CRT and PCB assembled. When repair, etc. is required at the time of malfunctioning, be sure to send it in an "as is assembled" condition. If these are disassembled, what's charged to said high tension voltage can be discharged, causing a very hazardous situation. Therefore, under no circumstances should it be disassembled.



CAUTION

● Static Electricity

Touching the CRT surface sometimes causes you to slightly feel electricity. This is because the CRT surfaces are subject to static and will not adversely affect the human body.

● Installation and removal

Ensure that the Magnetizer Coil, FBT (Fly-Back Transformer), Anode Lead and Focus Lead are not positioned close to the sheet metal work's sharp edges, etc. and avoid damaging the insulated portions so as not to cause electric shock and malfunctioning. (For the name of parts, refer to the above Figures).



CAUTION

For the purpose of static prevention, special coating is applied to the CRT face of this product. To protect the coating, pay attention to the following points. Damaging the coating film can cause electric shock to the customers.

- Do not apply or rub with a hard item (a rod with pointed edge, pen, etc.) to or on the CRT surfaces.
- Avoid applying stickers, seals, etc. on the CRT face.
- Do not remove aluminum foils from the CRT corners. Removing the aluminum foils can cause static prevention effects to be lowered.

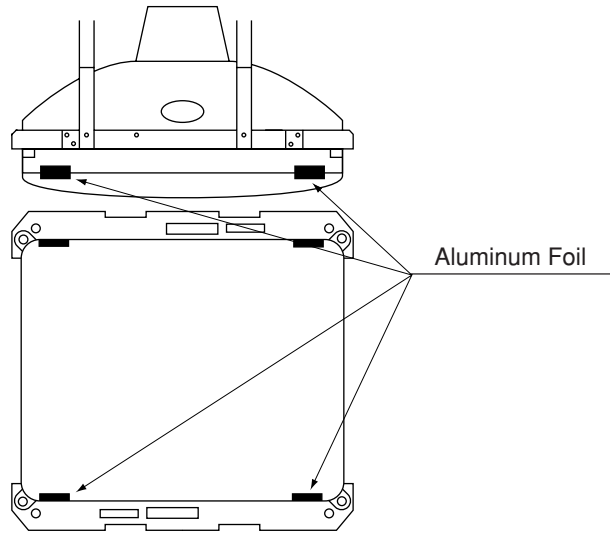

15 – 2 CLEANING THE CRT SURFACES



CAUTION

Static preventive coating is applied to the CRT surfaces. When cleaning, pay attention to the following points. Peeling off of static preventive coat can cause electric shock.

- Remove smears by using a dry, soft cloth (flannels, etc.). Do not use a coarse gauze, etc.
- For smear removing solvent, alcohol (ethanol) is recommended. When using chemical detergent, be sure to follow instructions below:
 - Dilute chemical detergent with water and dip a soft cloth in and then thoroughly wring it to wipe smears off.
 - Do not use a chemical detergent containing an abradant, powder or bleaching agent.
 - Do not use alkaline chemical detergents such as "glass cleaner" available on the market or solvents such as thinner, etc.
- Do not rub or scratch the CRT face with hard items such as brushes, scrub brush, etc.

Clean the CRT surfaces once a week. When cleaning, pay attention to the above caution so that the antistatic coating will not come off.



- Monitor adjustments have been made at the time of shipment. Therefore, do not make further adjustment without a justifiable reason. Adjusting the monitor which contains high tension parts is a dangerous work. Also, an erroneous adjustment can cause deviated synchronization and image fault, resulting in malfunctioning.
- Be sure to perform appropriate adjustment of the monitor (projector). For operation of this machine, do not leave monitor's flickering or deviation as is. Failure to observe this can cause to worsen the players' or the customers' physical conditions.
- Do not touch undesignated places. Touching places not designated can cause electric shock or short circuit.



Be sure to provide support for secured parts when removing the screws that secure them. Unsecured parts will fall then their screws are removed, possibly causing injury.

The monitor adjustment panel is located on the floor of the monitor box, on the right side when facing the screen. There is a settings board on the inside of this panel. The settings board is connected to the monitor by wires.

Remove the 2 screws holding the monitor settings panel in place and then remove the panel, pulling the wires along with it.

Settings can be changed by adjusting the switches while watching the screen.

SCREW (2), black

M4×16, w/flat & spring washers

MONITOR SETTINGS PANEL

SETTINGS BOARD

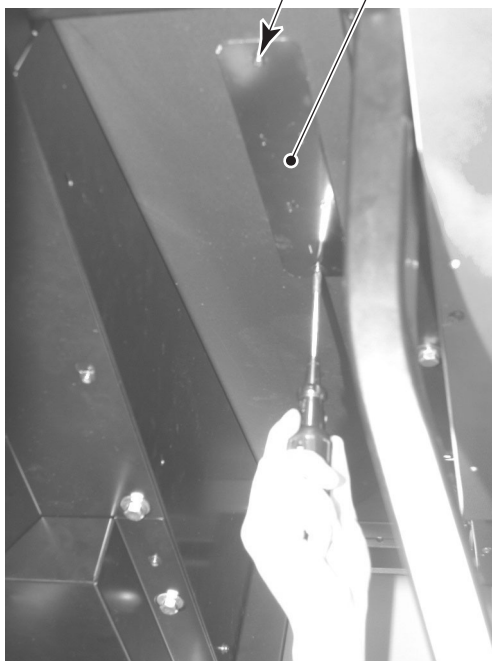
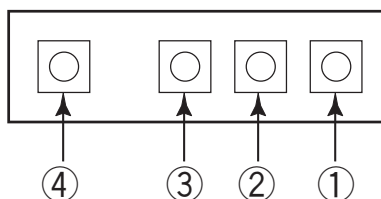

PHOTO 15.3 a



PHOTO 15.3 b

The monitor type of this product is "200-5955." Read the following thoroughly to adjust the monitor.



- ① F U N C (S A 0 4)
- ② U P (S A 0 3)
- ③ D O W N (S A 0 1)
- ④ D E G A U S S (S A 0 5)

There are four buttons to operate the adjustment. Pressing FUNC button displays the following menu screen. The item chosen is red, and the others are green. When there is no input of the button for 6 seconds, the menu display disappears.

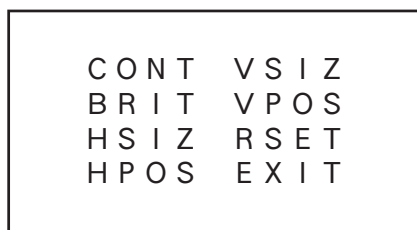

- C O N T : adjusts image contrast.
With the UP button, it becomes deep and becomes light with the DOWN button.
- B R I T : adjusts the on-screen image brightness.
With the UP button, it becomes bright and becomes dark with the DOWN button.
- H S I Z : adjusts the horizontal image size.
With the UP button, it becomes large and becomes small with the DOWN button.
- H P O S : adjusts the horizontal image's position.
With the UP button, it moves to the left and moves to the right with the DOWN button.
- V S I Z : adjusts the vertical image size.
With the UP button, it becomes large and becomes small with the DOWN button.
- V P O S : adjusts the vertical image's position.
With the UP button, it moves upwards and moves downwards with the DOWN button.
- E X I T : ends the adjusting mode and exits the menu.

· Each time the FUNC button is pressed, the selection item (red display) moves in following order.

"C O N T → B R I T → H S I Z → H P O S → V S I Z → V P O S → R S E T → E X I T → C O N T →"

- Select the item (red display) and press the UP or the DOWN button once, the following display will appear.



Contrast Adjusting Screen
The "nnn" is a present value of the adjustment value.

Pressing the UP/DOWN button again causes the adjusting works to be done. When there is no input of the UP/DOWN button for 6 seconds or the FUNC button is pressed, the adjustment value is memorized.

- If EXIT is selected (red display) and the UP/DOWN button is pressed, the adjustment mode will be canceled and the menu display will disappear.
- Selecting RSET and pressing the UP and the DOWN buttons simultaneously causes "RSET" to be displayed for 3 seconds and reset the on-screen setting status to the factory setting. Note that the factory setting status is predetermined and not changeable.
- When pressing the DEGAUSS button, degaussing is performed for 5 seconds and displays "DEGAUSS". Once degaussed, it takes 5 minutes or longer to have degaussing function again. If it is pressed before taking 5 minutes, the following screen will be appeared and display the remaining seconds.

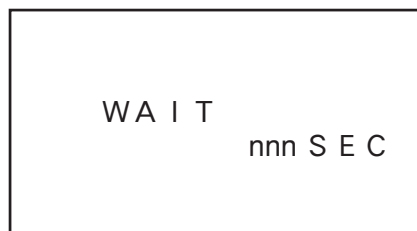

16. REPLACING THE FLUORESCENT LAMPS



- When performing work, be sure to turn power off. Working with power on can cause electric shock and short circuit hazards.
- The Fluorescent Lamp, when it gets hot, can cause burn. Be very careful when replacing the Fluorescent Lamp.



Be careful when handling the plastic parts. Failure to observe this may cause injury due to damage or fragments resulting from damage.

There is 1 fluorescent lamp inside each of the light boxes located on the top and bottom of the back of the cabinet.

Upper Lamp

- ① Turn off the power.
- ② Remove the 8 truss screws and then remove the upper light box plate.
- ③ Once the upper light box plate has been removed, the lamp can be replaced.

LIGHT BOX PLATE UPPER
TRUSS SCREW (8)
M4×8, flat washer used, chrome

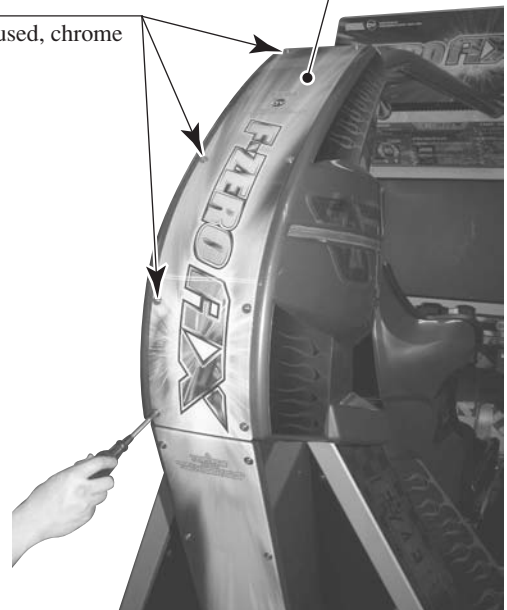

PHOTO 16 a



PHOTO 16 b

FLUORESCENT LAMP 20W WHITE: 390-5251-20-01
GLOW BULB: 390-5638-1P

Lower Lamp

- ① Turn off the power.
- ② Remove the 8 truss screws and then remove the lower light box plate.

TRUSS SCREW (8)
M4×8, flat washer used, chrome

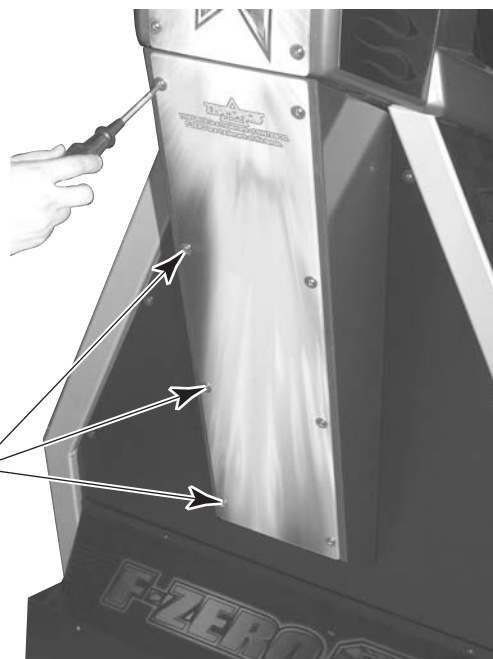

PHOTO 16 c

- ③ Once the lower light box plate has been removed, the lamp can be replaced.

LIGHT BOX PLATE LOWER

FLUORESCENT LAMP 20W WHITE: 390-5251-20-01
GLOW BULB: 390-5638-1P



PHOTO 16 d

17. PERIODIC INSPECTION TABLE

The items listed below require periodic check and maintenance to retain the performance of this machine and to ensure safe business operation.

When handling the controller, the player will be in direct contact with it . In order to always allow the player to enjoy the game, be sure to clean it regularly. Also, it is advisable to provide wet tissue, etc. available for player use.



- Be sure to check once a year to see if Power Cords are damaged, the plug is securely inserted, dust is accumulated between the Socket Outlet and the Power Plug, etc. Using the product with dust as is accumulated can cause fire and electric shock hazards.
- Never use a water jet, etc. to clean inside and outside the cabinet. If wetness occurs for any reason, do not use the product until it has completely dried.
- Periodically once a year, request the place of contact herein stated or the Distributor, etc. where the product was purchased from, as regards the internal cleaning. Using the product with dust as is accumulated in the interior without cleaning can cause a fire or accident. Note that cleaning the interior parts can be performed on a pay-basis.
- Contact the office listed In this manual or the product's point of purchase once a year for regular maintenance of the seat motion mechanism. Failure to service the mechanism may result in sudden breakdown and accidents.

TABLE 17

ITEMS	DESCRIPTION	PERIOD	REFERENCE
CABINET	Check Adjusters'contact with surface.	Daily	3
CARD READER/WRITER	Head cleaning	Every 151 counts of the card reader/writer or Daily	7
STEERING UNIT	Inspection of VR	Monthly	10, 11
	Inspection of adjusting gear mesh	Trimonthly	11-1, 12-1, 12-2
	Greasing	Trimonthly	11-3, 12-3
ACCEL. & BRAKE	Inspection of VR	Monthly	10, 13
	Gear and Spring portion greasing	Trimonthly	13-2
MONITOR	SCREEN cleaning.	Weekly	15-2
	Check adjustments.	Monthly or when moving.	6, 10, 15
COIN CHUTE DOOR	Inspection of COIN SW	Monthly	10
	Coin insertion test	Monthly	14
	Cleaning of COIN SELECTOR	Trimonthly	14
SEAT	Greasing to the seat rail	Trimonthly	FIG.17
GAME BD	MEMORY TEST	Monthly	10
	Check settings.	Monthly	10
POWER SUPPLY PLUG	Inspection and cleaning	Annually	See above.
INTERIOR	Cleaning		
CABINET SURFACES	Cleaning	As necessary	Next Page
MOVING MECHANISM	Maintenance	Annually	12-4

CLEANING THE CABINET SURFACES

When the cabinet surfaces are badly soiled, remove stains with a soft cloth dipped in water or diluted (with water) chemical detergent and squeezed dry. To avoid damaging surface finish, do not use such solvents as thinner, benzine, etc. other than ethyl alcohol, or abrasives, bleaching agent and chemical dustcloth.

SEAT (Greasing to Seat Rail Portion)

Move the Seat to the rearmost position and apply spray greasing to the portion shown at the right once every 3 months by using NOK KLUBER L60 or GREASE MATE SEGA PART No. 090-0066. After greasing, move the Seat a few times forward and backward so as to allow the grease to be applied all over uniformly. Be sure to wipe grease which attaches to the surfaces of the PROTECT RUBBER on the Seat Rail, or any excess grease.

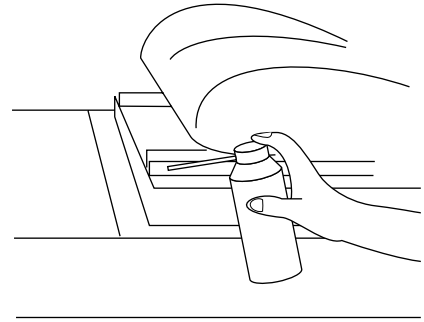

FIG. 17

18. TROUBLESHOOTING



- If an error code is displayed, have the site maintenance individual or other skilled professional resolve it. If someone without specialized or technical knowledge attempts to rectify the problem, electric shock, short circuits or fire may result. If there is no site maintenance individual or technician available, turn the power OFF immediately, and contact your retailer or the office listed in this manual.
- If problems other than those noted in this manual occur, or the countermeasures suggested result in no improvement, do not try to rectify the problem by other means. Turn the power OFF immediately, and contact your retailer or the office listed in this manual. Careless countermeasures can result in unexpected accidents.

18 — 1 CARD READER/WRITER



- If an error occurs in the card reader/writer, the machine will not be able to update data on cards. There is also a chance that card data may have been damaged.
Attempting to use a card with damaged data will trigger another error. Explain to the player that in order to determine whether the card can be used or not, he or she must play the game again. If the player wishes to play again, press the SERVICE Button to give him or her a credit.
- If errors occur repeatedly, perform a head cleaning.

If the machine detects a problem while the machine's card reader/writer is in use, it will display an error message from Table 18.1a. The message will also be displayed if a problem is detected while testing the reader/writer. (see 10-3F.)

If an error occurs in the card reader/writer, the machine will not be able to update data on cards. There is also a chance that card data may have been damaged. Attempting to use a card with damaged data will cause the same error message to be displayed again.

Explain to the player that in order to determine whether the card can be used or not, he or she must play the game again.

If there is data left over from an update in progress, the machine will display a message from Table 18.1b. By following the instructions contained in the message, the data can be transferred to a new card from the dispenser.

Table 18.1a

ERROR MESSAGES	COUNTERMEASURES
Error occurred. Please notify the store attendant. Read-Error.	Eject the card and ask the player to play again to determine whether the card can be used the next time he or she plays.
Error occurred. Please notify the store attendant. Write-Error.	Eject the card and ask the player to play again to determine whether the card can be used the next time he or she plays.
Error occurred. Please notify the store attendant. Print-Error.	Eject the card and ask the player to play again to determine whether the card can be used the next time he or she plays.
Shutter-Error. Please remove the card from the entry of the card reader. Press the VIEW-CHANGE-BUTTON after the card is removed.	Eject the card and return it to the player. The player's results have been recorded on the card. Check to make sure there are no foreign objects stuck in the card reader/writer. If there are no foreign objects, press the "View Change" button.
Error occurred. Please notify the store attendant. Card jam. Remove the card.	Remove the jammed card (see 7-3). Ask the player to play again to determine whether the card can be used the next time he or she plays.
Error occurred.	Displayed when a problem is detected during the power-up test. Check the wire connections on the card reader/writer.
Error occurred. Please notify the store attendant. The dispenser is out of the F-ZERO LICENSE CARD. Please refill the dispenser with the F-ZERO LICENSE CARD.	Refill the card dispenser as the message instructs (see 7-1).

Table 18.1b

MESSAGES
The last data of the F-ZERO LICENSE CARD still remains in the card reader. Writing the data will cost a new F-ZERO LICENSE CARD. Press START to write the data to the F-ZERO LICENSE CARD or step on the ACCELERATION-PEDAL to skip.

If a time has been set for card play to be turned off, the messages in Table 18.1c will be displayed at the selected time and players will no longer be able to use cards (see 10-3F).
If card play is disabled at a different time from the one intended, the time settings need to be revised.

The TRIFORCE contains an internal clock. If this clock is not set to the correct time, card play will be disabled at a time different from the actual time.

Table 18.1c

F-ZERO LICENSE CARDS will be out of service as the store is closing soon.
F-ZERO LICENSE CARDS cannot be used or purchased at this time.



When sending the machine's TRIFORCE out for repairs, do not disassemble it or remove the key chip.

TRIFORCE displays on-screen error messages indicating various types of malfunction. Games cannot be played when error messages are displayed. Below are listed some causes and countermeasures.

The TRIFORCE consists of a media board mounted on a main board. The TRIFORCE in this machine uses a DIMM board as its media board.

MEDIA BOARD IS NOT FOUND.

[DISPLAY]	MEDIA BOARD IS NOT FOUND.
[CAUSE]	MAIN BOARD or MEDIA BOARD is broken.
[COUNTERMEASURES]	With the MEDIA BOARD still attached to the MAIN BOARD, send the TRIFORCE for repair.

Error 01 [DISPLAY]	Error 01 This game is not acceptable by main board.
[CAUSE]	MEDIA BOARD is not inserted (completely) into the MAIN BOARD.
[COUNTERMEASURES]	Power off the unit, then reinsert the MEDIA BOARD. Should the problem persist, the BOARD may be damaged. Send the TRIFORCE to be repaired. Do not disassemble it.

Error 02 [DISPLAY]	Error 02 Main board malfunctioning.
[CAUSE]	MAIN BOARD is inoperative.
[COUNTERMEASURES]	Verify that the MAIN BOARD is connected properly. If this does not remedy the situation, send the TRIFORCE to be repaired. Do not disassemble it.

Error 03 [DISPLAY]	Error 03 Bad serial number on main board.
[CAUSE]	Unable to read MAIN BOARD serial ID.
[COUNTERMEASURES]	Disconnect the MEDIA BOARD from the MAIN BOARD and send the MAIN BOARD for repair. Send the TRIFORCE to be repaired. Do not disassemble it.

Error 04 [DISPLAY]	Error 04 Bad serial number on media board.
[CAUSE]	Unable to read MEDIA BOARD serial ID.
[COUNTERMEASURES]	With the MEDIA BOARD still attached to the MAIN BOARD, send the TRIFORCE for repair.

<p>Error 05 [DISPLAY]</p> <p>[CAUSE]</p> <p>[COUNTERMEASURES]</p>	<p>Error 05 This game is not acceptable by main board. The game is a foreign edition. Use the domestic version of the game.</p>
<p>Error 11 [DISPLAY]</p> <p>[CAUSE]</p> <p>[COUNTERMEASURES]</p>	<p>Error 11 JVS I/O board is not connected to main board. (1) I/O BOARD is not connected. (2) Unreliable connection between MAIN BOARD and I/O BOARD. (1) Connect the I/O BOARD to the MAIN BOARD. Verify that the power cable is connected to I/O BOARD. (2) Reconnect or replace the JVS CABLE that connects the I/O BOARD to the MAIN BOARD.</p>
<p>Error 12 [DISPLAY]</p> <p>[CAUSE]</p> <p>[COUNTERMEASURES]</p>	<p>Error 12 JVS I/O board does not fulfill the game spec. Correct I/O BOARD is not connected. Use an I/O BOARD that provides the proper input/output for the game.</p>
<p>Error 21 [DISPLAY]</p> <p>[CAUSE]</p> <p>[COUNTERMEASURES]</p>	<p>Error 21 This game is not acceptable by main board. Game data loaded from the GD-ROM to the DIMM BOARD is corrupted. Verify the GD-ROM DRIVE and TRIFORCE connection. Check the GD-ROM disc for scratches, dust or dirt.</p>
<p>Error 22 [DISPLAY]</p> <p>[CAUSE]</p> <p>[COUNTERMEASURES]</p>	<p>Error 22 Communication error occurred between main board and media board. No response from DIMM BOARD to MAIN BOARD. Ensure that the DIMM BOARD and the GD INTERFACE BOARD are properly connected. Should the problem persist, the DIMM BOARD or GD INTERFACE BOARD may be damaged. Send the TRIFORCE to be repaired. Do not disassemble it.</p>
<p>Error 23 [DISPLAY]</p> <p>[CAUSE]</p> <p>[COUNTERMEASURES]</p>	<p>Error 23 GD-ROM drive cover is open. The GD-ROM DRIVE cover is open. Ensure the GD-ROM DRIVE cover is firmly closed.</p>

<p>Error 24 [DISPLAY]</p> <p>[CAUSE]</p> <p>[COUNTERMEASURES]</p>	<p>Error 24 GD-ROM is not found. GD-ROM disc is not found. Insert the GD-ROM disc correctly. Verify that the disc is a TRIFORCE GD-ROM disc. Check the GD-ROM disc for scratches, dust or dirt.</p>
<p>Error 25 [DISPLAY]</p> <p>[CAUSE]</p> <p>[COUNTERMEASURES]</p>	<p>Error 25 Cannot access GD-ROM drive. (1) Unable to access GD-ROM DRIVE. (2) The GD-ROM DRIVE cover is open. (1) Verify that the GD CABLE and the power cable are properly connected to the GD-ROM DRIVE. (2) Close the GD-ROM cover securely. Should the problem persist, the GD-ROM DRIVE may be damaged.</p>
<p>Error 26 [DISPLAY]</p> <p>[CAUSE]</p> <p>[COUNTERMEASURES]</p>	<p>Error 26 Media board malfunctioning. KEY CHIP is not found. Attach the proper KEY CHIP for the game. Insert the KEY CHIP securely.</p>
<p>Error 27 [DISPLAY]</p> <p>[CAUSE]</p> <p>[COUNTERMEASURES]</p>	<p>Error 27 DIMM memory is not enough. (1) Insufficient DIMM MEMORY on DIMM BOARD. (2) DIMM MEMORY is not connected securely. (1) Provide a suitable amount of DIMM MEMORY for the software. (2) Verify that the DIMM MEMORY is connected securely to the DIMM BOARD. This error cannot occur in this machine. In the unlikely event that it does occur, send the TRIFORCE to be repaired. Do not disassemble it.</p>

Error 31
[DISPLAY]

[CAUSE]

[COUNTERMEASURES]

Error 31

This game is not acceptable by main board.

The game has not been downloaded into the DIMM BOARD from the HOST MACHINE.

Check network connections.

Verify that the PC is connected to the network.

Reset the main power. Wait until the game is displayed on the main screen, then turn the satellite power on and reboot.

In Test Mode, select NETWORK SETTING from the SYSTEM MENU and check that the NETWORK TYPE is set to ETHER.

In Test Mode, select NETWORK SETTING from the SYSTEM MENU, go to SET IP ADDRESS and verify that the REMOTE setting is appropriate for the game in use.

Check the internal DIMM BOARD battery is functioning correctly.

This error cannot occur in this machine. In the unlikely event that it does occur, send the TRIFORCE to be repaired. Do not disassemble it.

Error 32
[DISPLAY]

[CAUSE]

[COUNTERMEASURES]

Error 32

DIMM memory is not enough.

(1) Insufficient DIMM MEMORY on DIMM BOARD.

(2) DIMM MEMORY is not connected securely.

(1) Ensure there is sufficient DIMM MEMORY for the software.

(2) Verify that the DIMM MEMORY is connected securely to the DIMM BOARD.

This error cannot occur in this machine. In the unlikely event that it does occur, send the TRIFORCE to be repaired. Do not disassemble it.

Error 33
[DISPLAY]

[CAUSE]

[COUNTERMEASURES]

Error 33

Gateway is not found.

HOST MACHINE is not found.

Attach the KEY CHIP designed to support the game. Make certain that the KEY CHIP is inserted completely.

This error cannot occur in this machine. In the unlikely event that it does occur, send the TRIFORCE to be repaired. Do not disassemble it.

Caution 51
[DISPLAY]

[CAUSE]

[COUNTERMEASURES]

Caution 51

Wrong video output setting of horizontal scanning frequency.

The game does not support horizontal sync frequency setting.

Change the No. 6 DIPSW on the CONNECTOR BOARD.

ON is 31 kHz, OFF is 15 kHz.

The monitor must support these frequencies.

This option must be set to ON for this machine.

Caution 52
[DISPLAY]

[CAUSE]

[COUNTERMEASURES]

Caution 52

Wrong video output setting of horizontal/vertical screen.
The game does not support the vertical/horizontal screen settings.

Change the No. 4 DIPSW on the CONNECTOR BOARD.
ON is for vertically placed monitor screens, OFF is for horizontally placed monitor screens.

Change the monitor placement from vertical to horizontal or vice versa if necessary.

This option must be set to OFF for this machine.



This section deals with the interior of the machine when electric current is flowing through it. Avoid accidentally touching any part of the machine. Doing so may result in electric shock and/or short circuits.



Do not change the values of the dipswitches on the machine's motherboard from their factory settings. Doing so will disrupt the machine's functions when using or operating the machine.

If an error is detected during the initialization process that occurs when the machine is turned on, a message will be displayed on the drive board's 7-segment display. These messages are described below; use them as reference to identify and resolve the problem.

The drive board is located on the assembly I/O board in the base interior. With the power turned on, remove the 2 truss screws securing floor L and then remove the floor to reach the assembly I/O board.

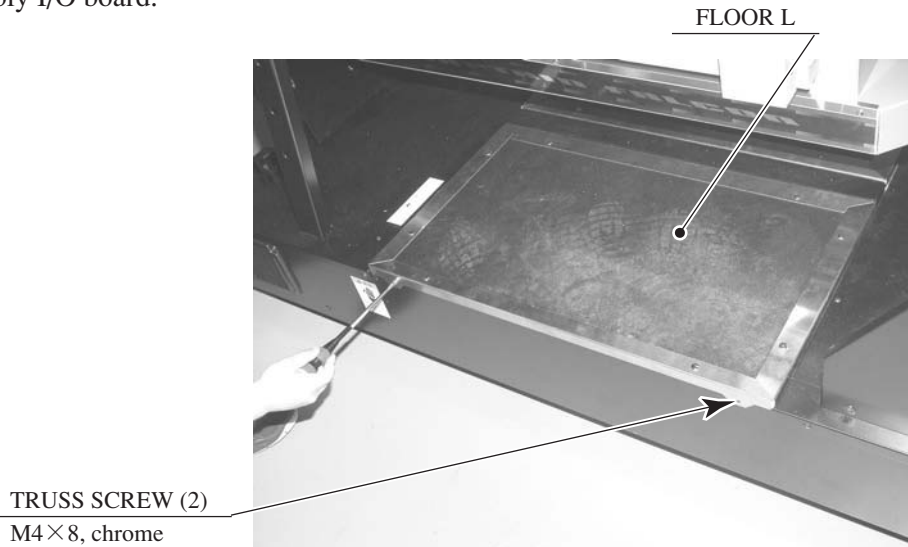

PHOTO 18. 3 a

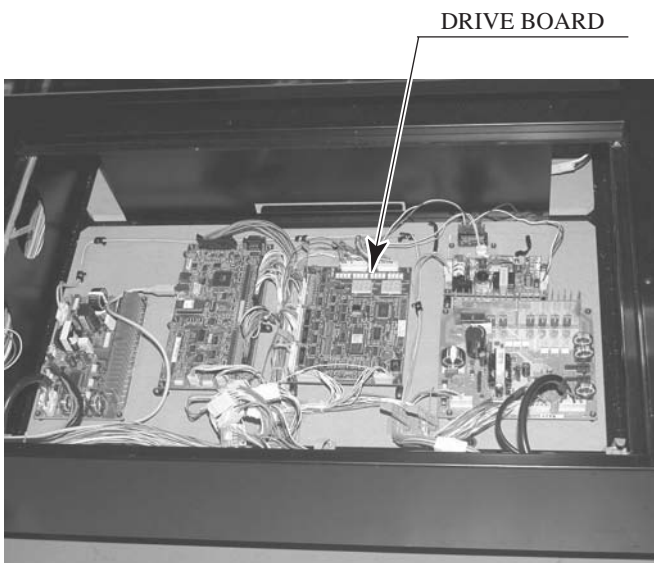

PHOTO 18. 3 b ASSY I/O BD

【MESSAGE】	Er01: RAM Error
【CAUSE】	There is a problem with the RAM on the drive board.
【COUNTERMEASURES】	If the error persists after turning the power off and on again, send the board to be repaired.
【MESSAGE】	Er02: ROM Error
【CAUSE】	There is a problem with the ROM on the drive board.
【COUNTERMEASURES】	If the error persists after turning the power off and on again, send the board to be repaired.
【MESSAGE】	Er03: Interrupt Error
【CAUSE】	There is a problem with an interrupt on the drive board.
【COUNTERMEASURES】	If the error persists after turning the power off and on again, send the board to be repaired.
【MESSAGE】	Er20: Starting Point Error
【CAUSE】	The motor's starting point cannot be found.
【COUNTERMEASURES】	Check to see if there are any objects impeding the motor's movement and then turn the power off and on again.
【MESSAGE】	Er22: Centering Error
【CAUSE】	One or more variable resistor values are not changing correctly.
【COUNTERMEASURES】	Check to make sure the VR values are correct.
【MESSAGE】	Er23: Encoder Error
【CAUSE】	Error in the encoder data.
【COUNTERMEASURES】	Check all the wiring to the encoder.
【MESSAGE】	Er24: Excess Current Error
【CAUSE】	The motor experienced excess current flow.
【COUNTERMEASURES】	Check to see if there are any problems with the wires connected to the motor.
【MESSAGE】	Er25: Overload Error
【CAUSE】	The motor's thermal element was activated.
【COUNTERMEASURES】	Wait for the temperature to cool and then turn the power off and on again.

18 — 4 OTHER MECHANICAL ERROR MESSAGES (EXCL. CARD READER/WRITER)

If a mechanical error occurs somewhere other than the card reader/writer, the screen will read "Error XX Occurred".

The following list contains descriptions of each error and how to deal with them.

Error01

【CONTENTS】

Cabinet - I/O Error

The machine is unable to communicate with the board that controls seat motion. Check the wiring.

Error02

【CONTENTS】

【COUNTERMEASURES】

Cabinet - Overheat/Overload Error

The thermal element on the motor responsible for seat motion was activated. Wait for it to cool down and then restart the machine.

Error03

【CONTENTS】

【COUNTERMEASURES】

Cabinet - Encoder Error

There is a problem with the data in the seat's motion encoder. Check to see if there are any problems with the wires connected to the encoder.

Error04

【CONTENTS】

【COUNTERMEASURES】

Cabinet - Excess Current Error

The motor responsible for seat motion experienced excess current flow. Check to see if there are any problems with the wires connected to the motor.

Error05

【CONTENTS】

【COUNTERMEASURES】

Steering - I/O Error

The machine is unable to communicate with the steering unit's reaction control board. Check the wiring.

Error06

【CONTENTS】

【COUNTERMEASURES】

Steering - Overheat/Overload Error

The thermal element on the steering unit's reaction motor was activated. Wait for it to cool down.

Error07

【CONTENTS】

【COUNTERMEASURES】

Steering - Encoder Error

There is a problem with the data in the steering unit's reaction encoder. Check to see if there are any problems with the wires connected to the encoder.

Error08

【CONTENTS】

【COUNTERMEASURES】

Steering - Excess Current Error

The steering unit's reaction motor experienced excess current flow. Check to see if there are any problems with the wires connected to the motor.



- In order to prevent electric shock and short circuit, be sure to turn power off before performing work.
- Be careful so as not to damage wirings. Damaged wiring can cause electric shock or short circuit.
- After removing the cause of the functioning of the Circuit Protector, reinstate the Circuit Protector. Depending on the cause of the functioning, using the Circuit Protector as is without removing the cause can cause generation of heat and fire hazard.
- In the event that a problem cannot be resolved by employing the procedures listed in this Manual, be sure to request service from the office shown on this Manual or the dealer from whom the product was originally purchased. Attempts to employ procedures other than those specified in this Manual can cause electrical shock, shorting, or fire.
- In the event of a problem that is not described here, be sure to contact the office shown on this Manual or the dealer from whom the product was originally purchased. Careless attempts at repair can result in electrical shock, shorting, or fire.

If a problem occurs, first check to make sure that the wiring connectors are properly connected.

TABLE 18. 5

PROBLEM	CAUSE	COUNTERMEASURES
When the main SW is turned ON, the machine is not activated.	The power is not ON.	Firmly insert the plug into the outlet.
	Incorrect power source/voltage.	Make sure that the power supply/voltage are correct.
	The CIRCUIT PROTECTOR functioned due to momentary overcurrent.	After eliminating the cause of overload, have the Circuit Protector of the AC Unit restored. (See Section 6 [4], Refer to the following.)
	The fuse of the fuse holder was blown out due to momentary overcurrent.	After eliminating the cause of overload, replace the specified rating fuse. (Fig. 18. 5 c)
Fluorescent lamp inside light box doesn't light up.	Connector connection fault.	Check connector connections between the Cabinet and the light box.
	Fluorescent lamp and Glow lamp need replacement.	Replace the fluorescent lamp and the glow lamp. (See Section 16.)

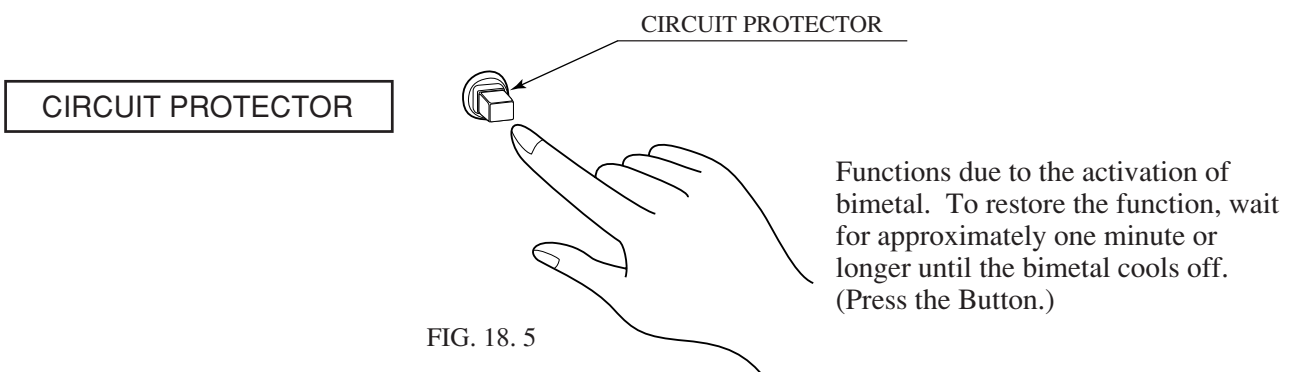

FIG. 18. 5

TABLE 18. 5

PROBLEM	CAUSE	COUNTERMEASURES
Sounds are emitted and the lamps are lit, but the screen is black.	Faulty connections for the visual signal connector or the monitor power connector.	Check the connections for the monitor and game board connectors.
	Broken monitor.	Contact the company from whom the unit was purchased.
Sound is not emitted.	Sound volume adjustment is not correct.	Adjust the Switch Unit's sound adjustment volume . (See Section 10.)
	Faulty connections for various connectors.	Check the connections for the game board, amp, speakers and Volume connectors.
	Malfunctioning BD, Amp. and Speaker.	Perform SOUND TEST. (See Section 10.)
Irregular/uneven colors on the monitor screen.	Magnetization of the CRT.	Press the Demag. switch on the switch unit. (See Section 10.)
Colors on the monitor screen are strange.	Faulty connection for the visual signal connector.	Check the visual signal connector connection and make sure it is secured properly.
	Screen adjustment is not appropriate.	Make adjustment appropriately. (See Section 15.)
The on-screen image sways and/or shrinks.	The power source and voltage are no correct.	Make sure that the power supply and voltage are correct.
Does not accept input from any switch or volume.	Faulty connector connections.	Check the connection for the I/O Board and Cabinet connector.
		Check the power for the I/O Board.
STEERING (Servomotor) response is incorrect.	Incomplete power on check.	Power on and verify that the power on check completes properly. (See [5] of Section 6.)
	Deviation of the volume value.	Adjust the calibration in the Test Mode. (See Section 10.)
	Volume gear engagement fault.	Adjust the engagement of the gear. (See Sections 10, 11 & 12.)
	Volume malfunctioning.	Replace the volume. (See Sections 11 & 12.)
	Detached wires.	Check for faulty wire connections around moving parts. When replacing wires, secure them so that they do not touch any moving parts.

TABLE 18. 5

PROBLEM	CAUSE	COUNTERMEASURES
The seat's motion is unsatisfactory.	Incomplete power on check.	Power on and verify that the power on check completes properly. (See [5] of Section 6.)
	Deviation of the volume value.	Adjust the calibration in the Test Mode. (See Section 10.)
	Volume gear engagement fault.	Adjust the engagement of the gear. (See Sections 10, 11 & 12.)
	Volume malfunctioning.	Replace the volume. (See Sections 11 & 12.)
	Detached wires.	Check for faulty wire connections around moving parts. When replacing wires, secure them so that they do not touch any moving parts.
	The sensor is being triggered.	Check to see if there are any objects blocking the sensor.
	The sensor is malfunctioning.	Go into Test mode and check to make sure the sensor is functioning properly. (See Section 10.)
No response from Steering (Servomotor).	Failure of power-on checking procedure.	Reconnect the power and complete a power-on checking procedure. (See [5] of Section 6.)
	Faulty connector connections.	Check the connections for the connectors between the Game Board and Servodriver and between the Servodriver and the Servomotor.
	Thermal element in the Servomotor is operating.	Occurs when the internal temperature reaches 70°C (158°F) and corrects automatically when the unit cools.
	Momentary overload caused a fuse on the Servodriver to blow.	Contact the company from whom the unit was purchased.
Unsatisfactory Accel and Brake operation.	Incorrect volume setting.	Adjust the volume value in the Test Mode. (See Section 10.)
	Faulty Volume attachment or adjust gear alignment.	Adjust the volume attachment and verify in Test Mode. (See Sections 10 & 13.)
	Faulty connector connection.	Check the connections for the Accel and Brake connectors and the connectors between the Accel, Brake and Cabinet.
	Failure of the volume.	Replace the volume. (See Section 13.)

TABLE 18. 5

PROBLEM	CAUSE	COUNTERMEASURES
Failure of the network play.	Network play is wrongly set.	Reset correctly. (See Section 20.)
	Network cables are disconnected.	Reconnect the cables. (See Section 20.)
	Network cables are wrongly connected.	
	Damage of network cables.	Replace the cables. Contact the company from whom the unit was purchased.
Memory cards and license cards cannot be used.	The machine is set not to accept cards.	Change the settings in Test mode. (See Section 10.)

REPLACING FUSES



- In case fuse replacements other than those stated in this manual are necessary, contact where you purchased the product from for inquiries regarding this matter.
- In order to prevent an electric shock, be sure to turn power off and unplug from the socket outlet before performing work by touching the internal parts of the product.
- Be careful so as not to damage wirings. Damaged wiring can cause electric shock and short circuit accidents.
- Be sure to use fuses meeting specified rating. Using fuses exceeding the specified rating can cause fire and electric shock accidents.
- After eliminating the cause of the blowing of fuse, replace the fuse. Depending on the cause of fuse blowing, continued use with the fuse as is blown can cause generation of heat and fire hazard.
- For operations that require more than one person to perform, be sure to have the indicated number of personnel on hand. These operations cannot be performed safely or reliably with fewer people than indicated.

The fuses are located at the rear of the AC unit inside the base.

- ① Turn the main switch off and unplug the power cord from the outlet.
- ② Remove the front floor of the base. The front floor is more than 80 cm wide. At least 2 people are needed to perform this operation safely and reliably. Remove the 10 truss screws holding the front floor in place.

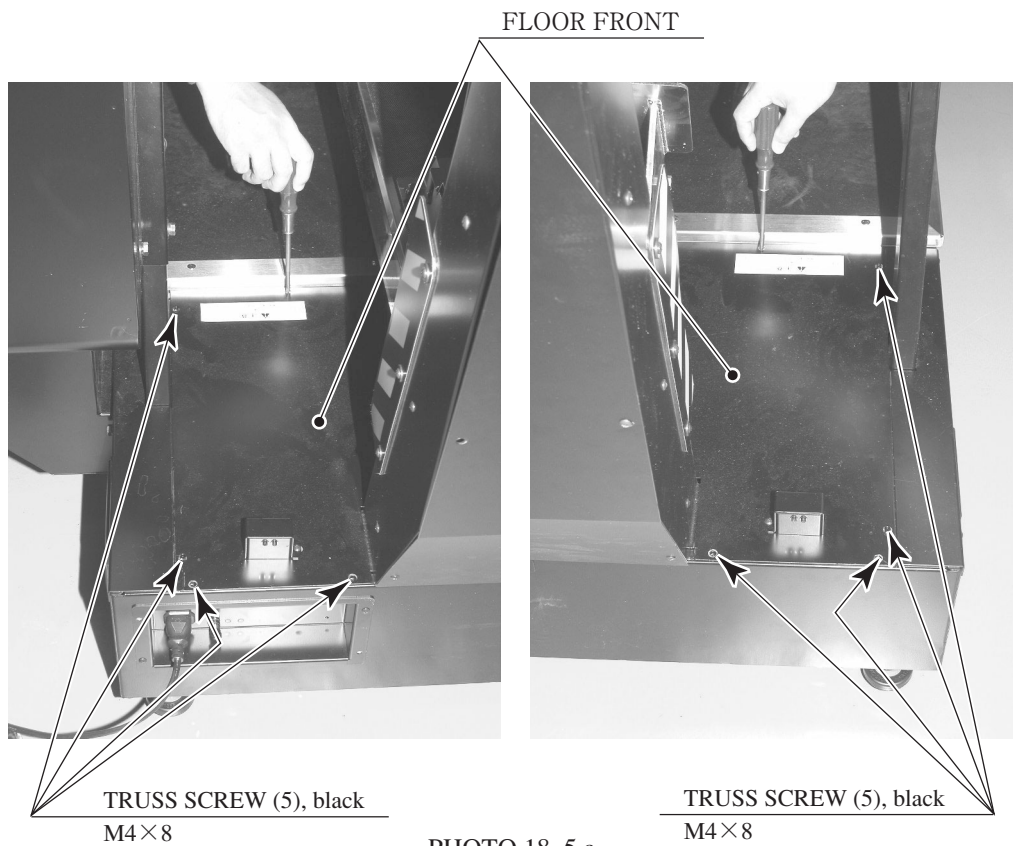

PHOTO 18. 5 a

- ③ There is a wire connection on the inside of the front floor. Lift the rear of the front floor (the side opposite the AC unit) and, holding it in a tilted position, unplug the single connector.

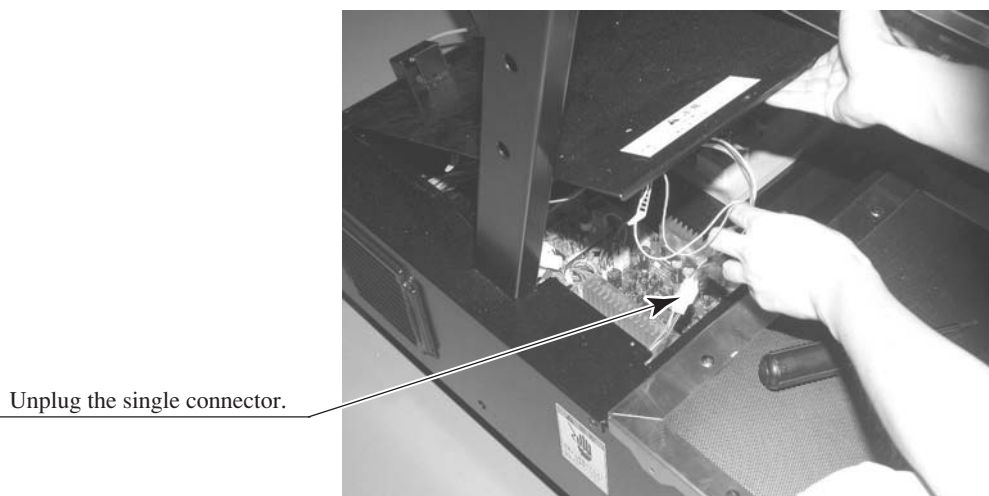

PHOTO 18. 5 b

- ④ Remove the front floor from the base.
- ⑤ The fuses are located within the base on the same side as the AC unit.

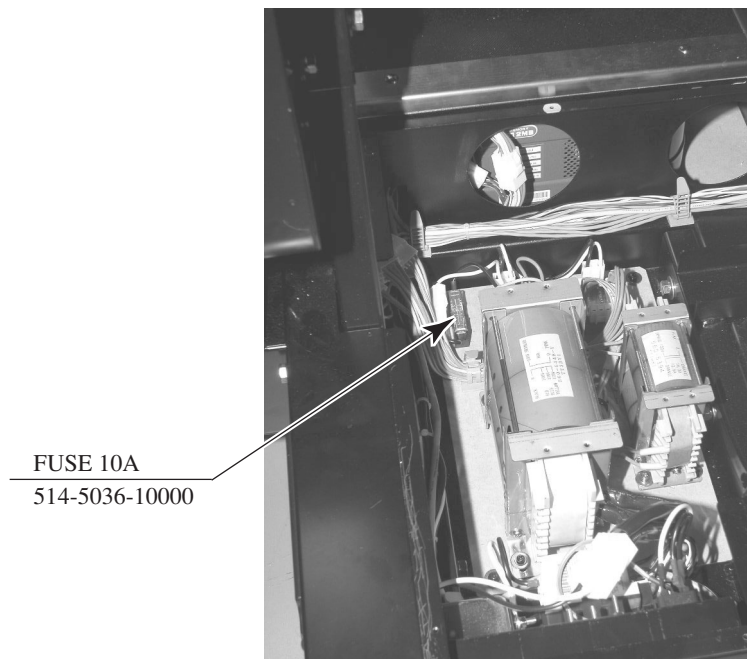

PHOTO 18. 5 c

19. GAME BOARD



WARNING

- In order to prevent electric shock and short circuit hazards, be sure to turn power off before performing work.
- Be careful not to damage the wires. Damaged wires may cause electric shock or short circuit or present a fire risk.
- Do not expose the Game BD, etc. without a good reason. Failure to observe this can cause electric shock hazard or malfunctioning.
- Do not use this product with connectors other than those that were connected and used with the Game Board at the time of shipping. Do not carelessly connect wires to connectors that were not used at the time of shipping, as this may cause overheating, smoke or fire damage.



CAUTION

- In this product, setting changes are made during the test mode. The Game BD need not be operated. Use the Game BD, etc. as is with the same setting made at the time of shipment so as not to cause electric shock and malfunctioning.
- Static electricity from your body may damage some electronics devices on the IC board. Before handling the IC board, touch a grounded metallic surface so that the static electricity can be discharged.



IMPORTANT

When having the game board replaced or repaired, use the included carton box to ship it. Do not disassemble it. If the board is not received in the proper condition, it may not be eligible for repair or replacement, or extra service charges may be applied.

The disassembly procedure for the game board is described in this manual for the purpose of replacing the battery inside the board. Do not disassemble the board when sending it in for replacement or repair.

19 — 1 REMOVING THE GD-ROM DRIVE

- ① Turn off the power

- ② Remove the right floor from the side of the base next to the coin chute tower. To unlatch the floor, remove the 2 truss screws.

Unlock.

TRUSS SCREW (2)
M4×8, chrome

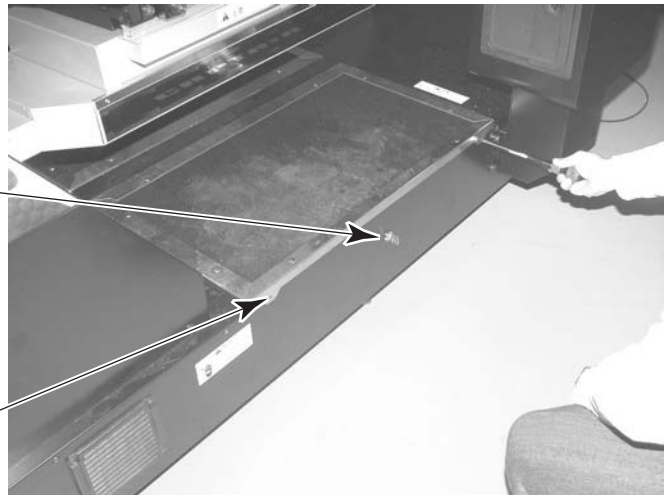

FLOOR R

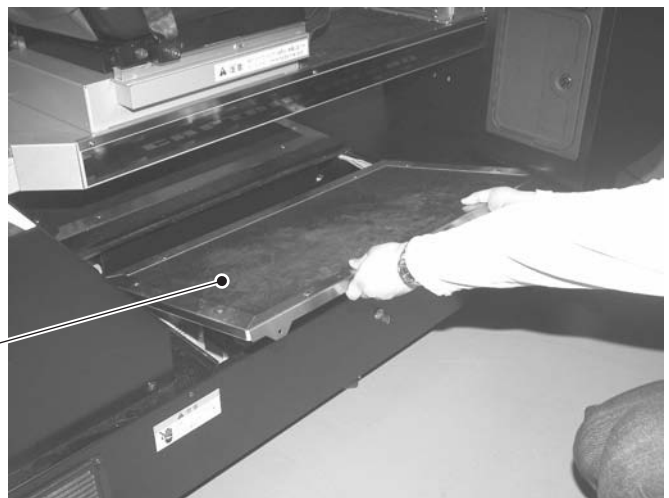

PHOTO 19. 1 a

- ③ Unfasten the 2 cord clamps securing the wires inside the base.

CORD CLAMP

GD CABLE

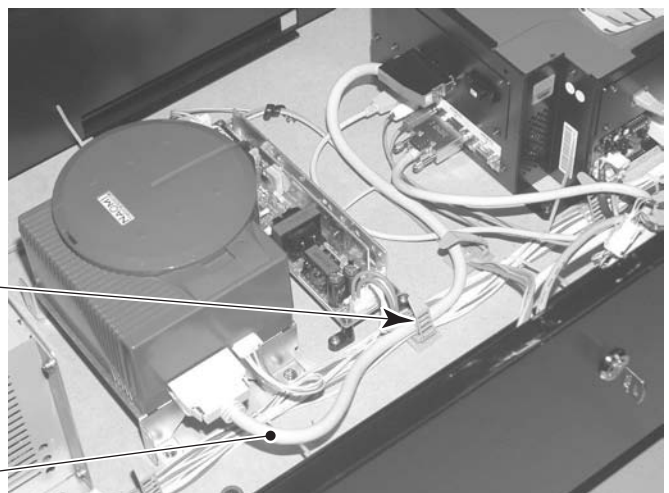

PHOTO 19. 1 b

- ④ Unplug the GD cable connector from the GD-ROM drive.

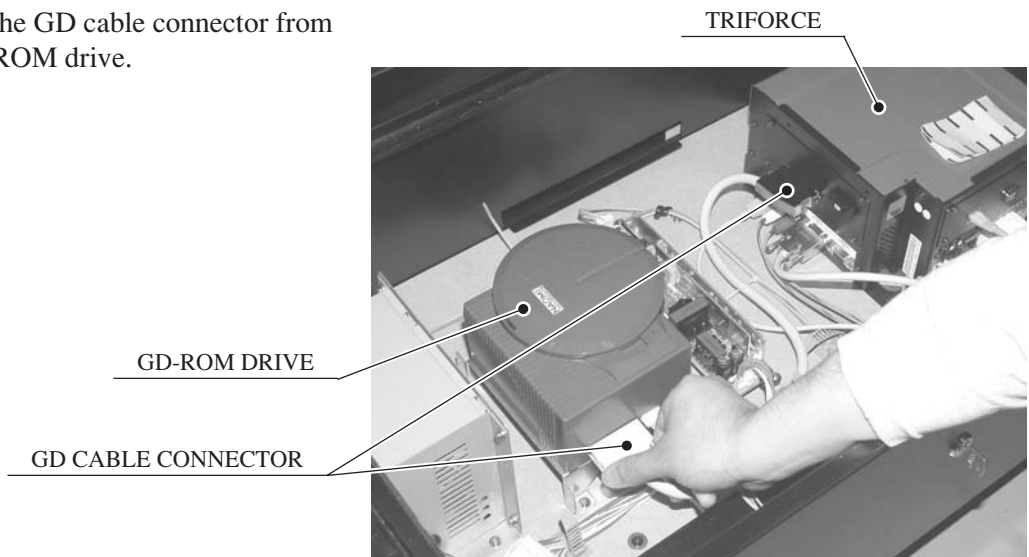

PHOTO 19.1 c

- ⑤ Unplug the power cable connector from the GD-ROM drive.

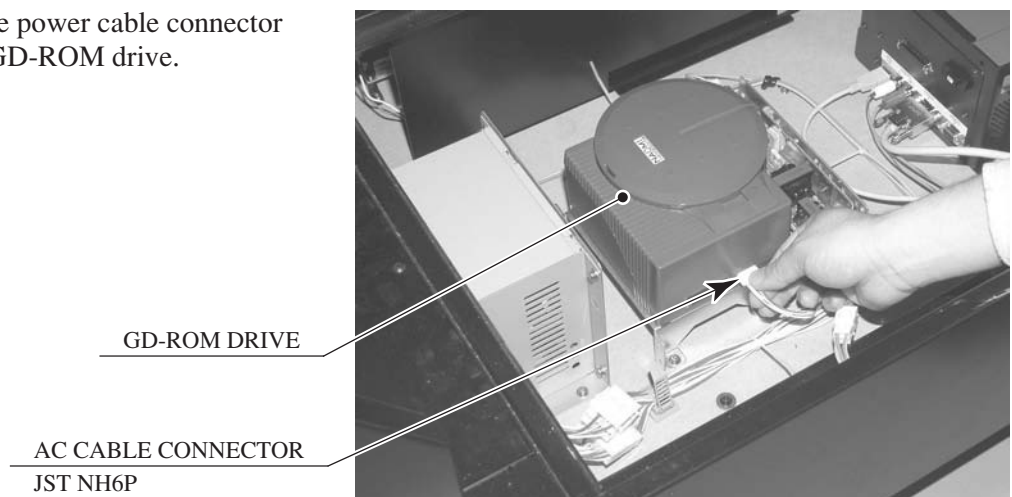

PHOTO 19.1 d

- ⑥ Remove the 3 screws and then remove the GD-ROM drive.

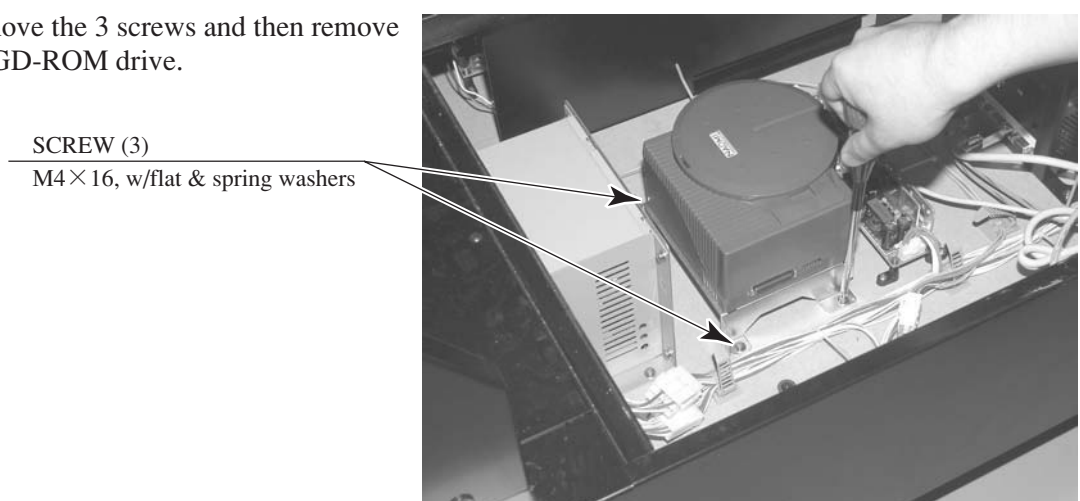

PHOTO 19.1 e

19 — 2 REMOVING THE GAME BOARD (TRIFORCE)



- When returning the game board for replacement or repair, make sure that the connectors are attached correctly. Incorrect connections can lead to accidents such as electric shock, short circuits, and/or fire.
- When plugging in connectors, pay close attention to the direction of the connection. The connectors are designed to be connected in a specific direction. Attempting to plug in a connector by applying excessive force may damage the connector or its terminal clasp, possibly resulting in electric shock, short circuits, and/or fire.

- ① Follow steps 1 through 3 of the GD-ROM drive removal procedure.
- ② Unplug all connectors from the game board (TRIFORCE).

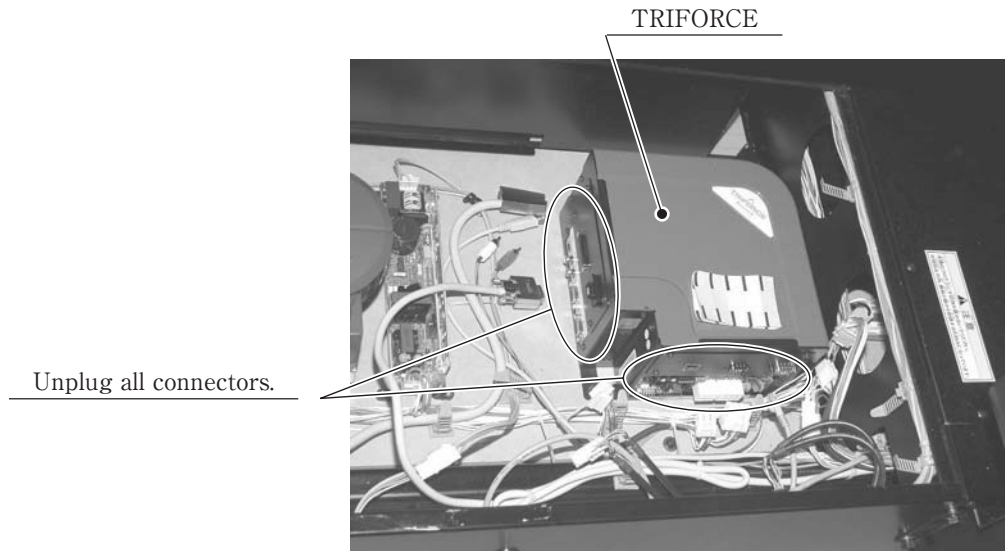

PHOTO 19.2 a

- ③ Once the 3 screws holding the game board in place have been removed, the board itself can be removed.

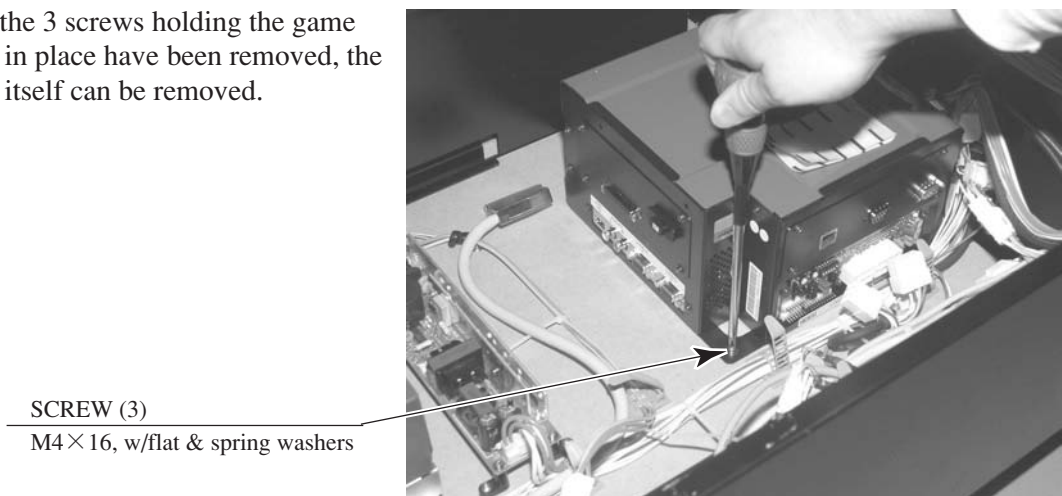

PHOTO 19.2 b



With the key chip installed, the TRIFORCE board becomes a proprietary game board for this product.

- ASSY TRF FZR USA (842-02DD511U): USA
- ASSY TRF FZR EXP (842-02DD511E): OTHERS
- ASSY TRF FZR ASIA (842-04DD511E): ASIA

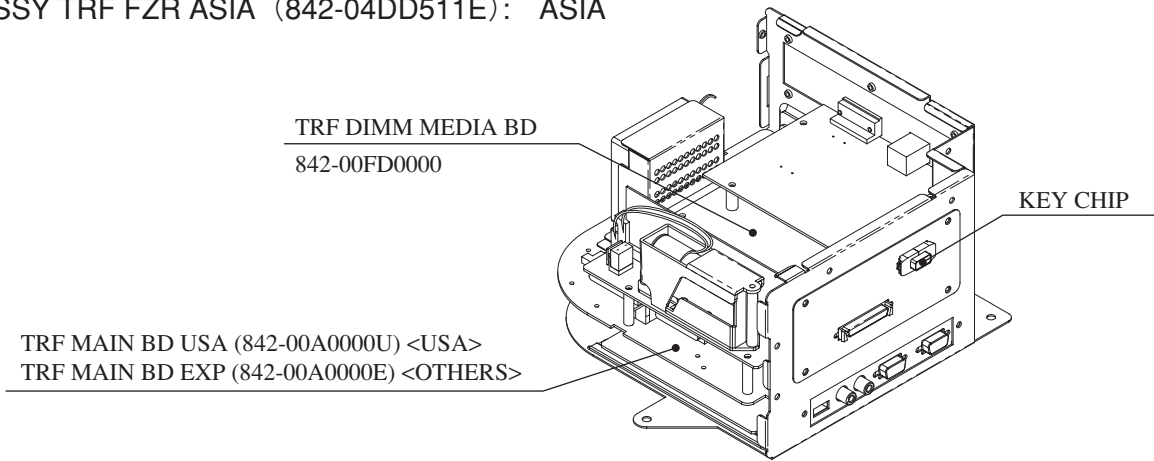

FIG. 19.3 a

DIP SW SETTING

Use this product with the DIP SW settings shown in the figure below.

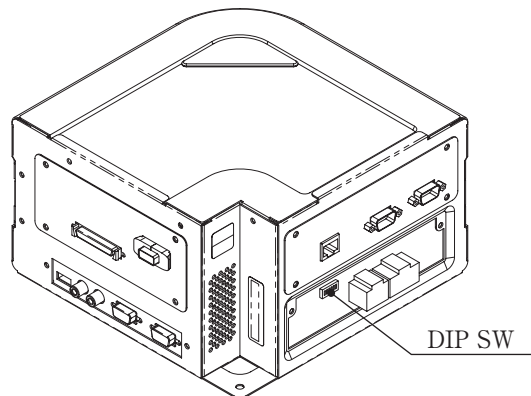

FIG. 19.3 b



- To prevent overheating, explosion, or fire:
 - Do not recharge, disassemble, heat, incinerate, or short the battery.
 - Do not allow the battery to come into direct contact with metallic objects or other batteries.
 - To preserve the battery, wrap it in tape or other insulating material.
- Follow local regulations when disposing of the battery. Improper disposal can damage the environment.



- To avoid risk of malfunction and damage:
- Make sure the positive and negative ends are aligned correctly.
 - Use only batteries approved for use with this unit.



If an error appears indicating that the battery power is very low within the first year of use, it is usually an indication of a problem or abnormality with something other than the battery. Be sure to inspect the board that the battery is connected to.

- ① Remove the 5 screws holding the TRIFORCE and its cover in place.
- ② Slide the cover off of the TRIFORCE, being careful of the hook that holds them together.

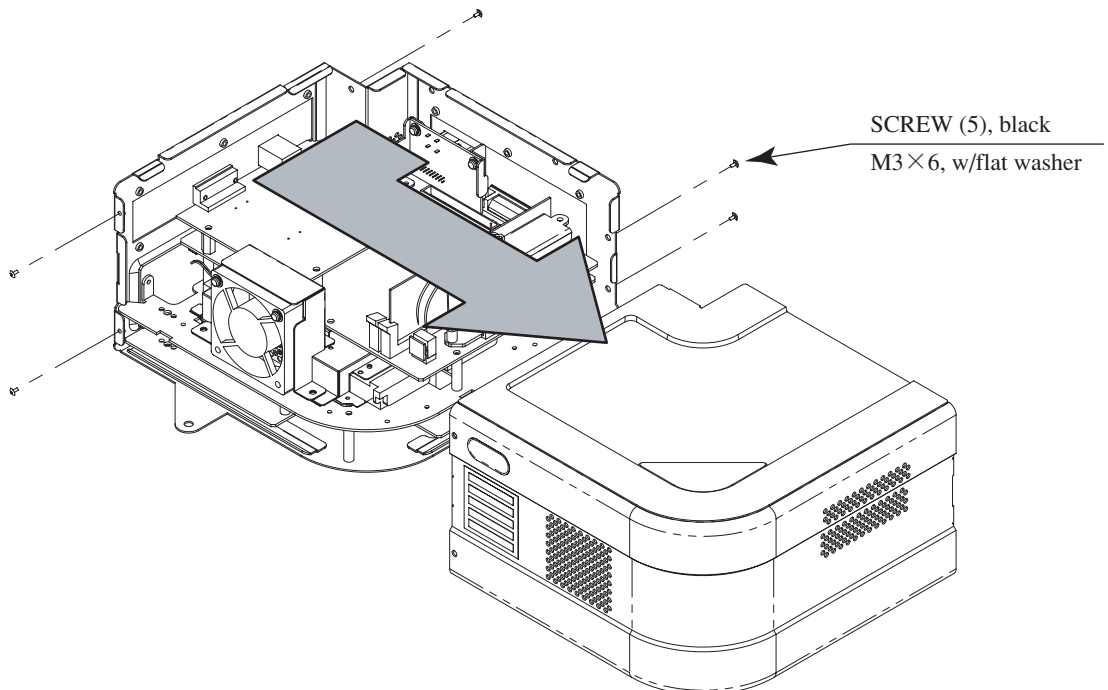

FIG. 19. 4 a

- ③ Gently remove the battery from the battery holder. The battery holder is located on the very bottom of the main board.
- ④ Insert the new battery (CR2032) so that the + terminal is pointing upward.

Removed batteries should be disposed of in accordance with relevant national laws and/or local regulations.

TRIFORCE MAIN BOARD BATTERY

SEGA PART No.: 401-0065

SEGA PART NAME: BATTERY CR2032 HITACHI

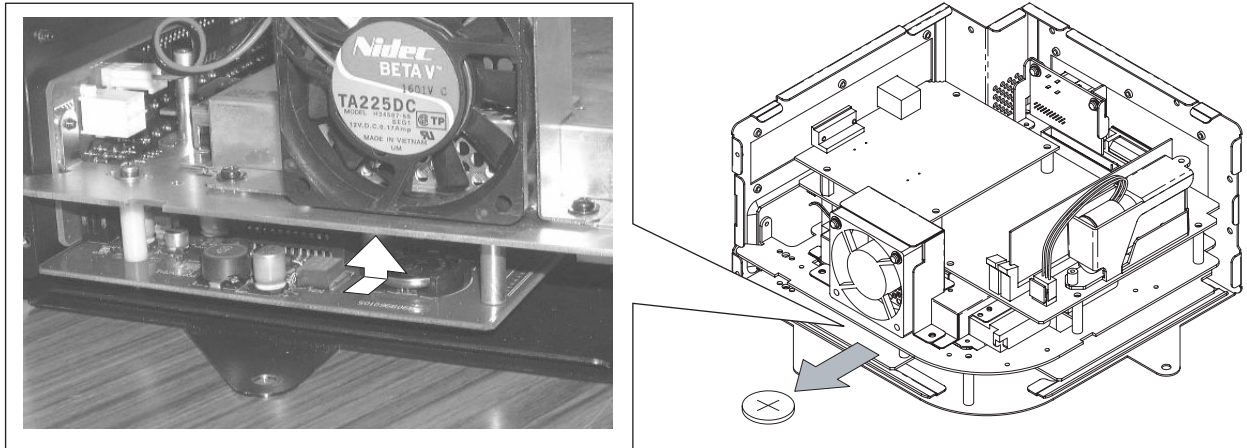

FIG. 19.4 b

WARNINGS AND RESTRICTIONS CONCERNING USE OF BATTERY PACK

Observe the following precautions when handling the DIMM board's battery pack. Sega cannot assume responsibility for any problems that arise from handling the battery pack in disregard of the guidelines set forth in the manual.



- Do not disassemble the battery pack and the batteries.
If you should fail to observe this instruction, the internal wires and/or protective devices may be damaged; as a result the safety system may not function when discharging and recharging, eventually causing an overheating, fire and explosion. If you should disassemble the batteries, the generated gases may harm your throat and the negative plate may overheat and make a fire.
- Do not make an external short circuit of the battery pack and the batteries.
If you should fail to observe this instruction, the batteries may overheat, make a fire, and explode.
- Do not fire the battery pack and the batteries.
If you should fail to observe this instruction, the batteries may make a fire and explode.
Do not leave the battery pack and the batteries nearby the heat source (fire or heater) or under the intense direct sunlight and flaming sun. If you should fail to observe this instruction, the batteries may reduce the service life and in the worst case may overheat, make a fire, and explode.
- Do not leave the battery pack and the batteries in water or seawater. Also do not apply water or seawater onto the battery pack and the batteries. If you should fail to observe this instruction, the internal wires and/or protective devices may be damaged; as a result the safety system may not function when discharging and recharging, eventually causing an overheating, fire and explosion. Also water may be electrolyzed into oxygen and hydrogen, and eventually the battery's sealed section may be corroded and the internal liquid may leak.
- Do not solder on the battery pack's terminals.
If you should fail to observe this instruction, the armor may be heated and melted or the internal wires may be damaged, eventually causing an overheating, fire and explosion. Also, when the battery's temperature reaches to 100°C or more, the battery may leak its internal liquid due to destruction of its plastic parts (gasket, separator, etc.), or may overheat, make a fire, or explode due to internal short-circuit.
- Do not insert or connect the battery in a reversal polarity.
If you should fail to observe this instruction, the battery may be externally short-circuited and eventually overheat, make a fire, or explode, depending on the device you connect with.



- Do not tightly seal the battery pack when installing it onto an external device.
Flammable gas is generated from the battery when its safety mechanism has functioned. If you should fail to observe the above-described instruction, sparks from motors, switches, etc. may cause the gas to fire. Therefore, install the battery pack so that the gas can be quickly released from the external device.
- Do not use the battery pack for the device/usage other than this game system.
If you should fail to observe this instruction, the battery and/or the device may be damaged due to non-applicable specifications.
- Do not strike a nail in, hammer, step on, or apply any other forms of pressures and shocks on, the battery.
If you should fail to observe this instruction, the battery may be deformed. As a result, the battery may burst at its sealed sections to leak the internal liquid, or may be short-circuited internally to overheat, make a fire, and explode.
- Do not use a battery charger because any battery charger is not usable for this battery pack.
If you should fail to observe this instruction, the gas may be suddenly generated in the battery and eventually the battery may overheat, make a fire or explode.
- If the battery in use or in keeping shows an abnormal indication (deformation, change of color, bursting of the armor cover, etc.), immediately stop using or keeping it. If it leaks and smells abnormally, immediately keep it away from fire and put it in a safety box.
- If the liquid leaks from the battery and gets in your eyes, do not rub your eyes but immediately wash them with clean water (city water etc.); and consult a medical doctor for a treatment. If you should fail to observe this instruction, the liquid may harm your eyes.
- The battery pack armor (a polyvinyl chloride tube) may be damaged or deformed by external force or heat. When transporting the battery pack or replacing it with a new one, therefore, be careful not to drop or excessively shock it. Do not continue to use any damaged or deformed battery pack. If you should fail to observe this instruction, the battery may overheat, make a fire, or explode.
- The battery pack contains a printed circuit board (PCB) for protective circuitry. It may be destroyed by the static electricity. When handling or servicing the battery pack, therefore, take preventive measures against the static electricity.
If your battery pack has shown destruction of a protective circuitry PCB, do not continue to use it. If you should fail to observe this instruction, the battery may overheat, make a fire, or explode.
- When wiring the battery pack to a device, be careful not to apply excessive force onto the connectors and lead wires. The battery may overheat, make a fire, or explode if the connectors and lead wires are damaged.
- Do not do away with the used battery packs carelessly because they may contaminate the environment. Submit them to an industrial waste disposal plant.
- Be sure to dispose of the used battery pack in accordance with relevant national laws and/or local regulations.

If the GD-ROM drive appears to be taking too long to read the disc, the battery pack on the DIMM board may need replacing. The battery pack should last approximately 16 months under normal usage.

There is no recharging unit for the battery pack.

Follow the steps listed below to replace the battery pack.

- ① Follow steps 1 and 2 in Section 19-4 to remove the cover.
- ② Unplug the battery pack's connector.
- ③ Remove the single tapping screw and slide the battery holder cover to remove it.
- ④ Remove the battery pack.
- ⑤ Repeat the above steps in reverse to install the new battery pack.

The used battery pack is considered industrial waste.

As such, it should be disposed of in accordance with relevant national laws and/or local regulations.

DIMM BOARD BATTERY PACK

SEGA PART No.: 401-0081

SEGA PART NAME: BATTERY PACK CGR-B/246A

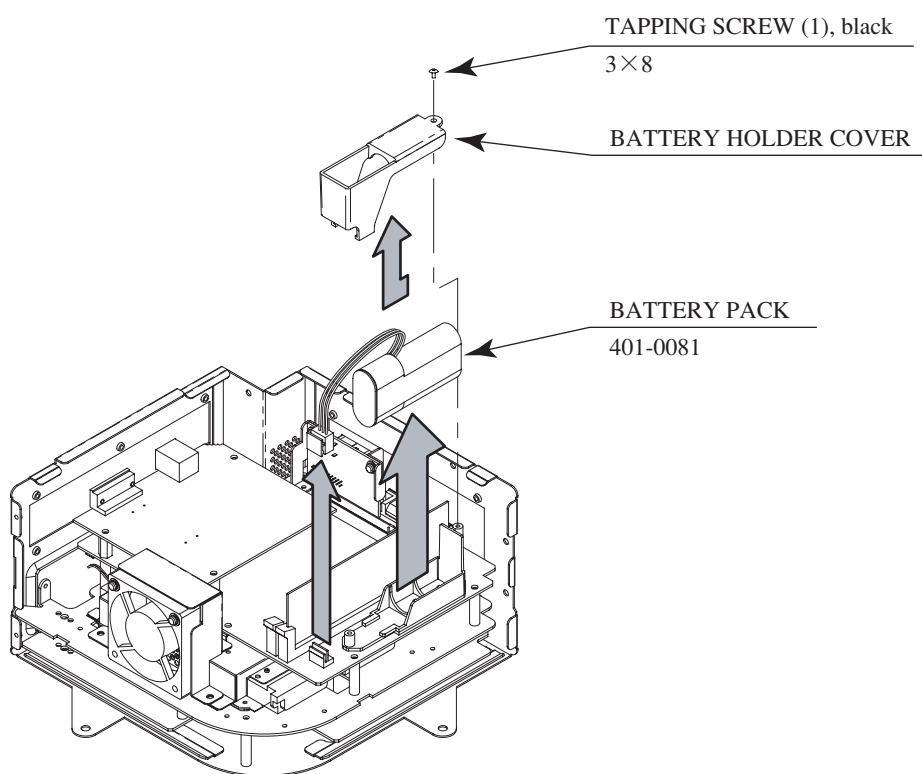

FIG. 19.5

19 — 6 SHIPPING THE GAME BOARD AND GD-ROM DRIVE

Observe the following precautions when sending the TRIFORCE or GD-ROM drive out for servicing or repairs.

The carton boxes (included) are needed to ship these parts, and should therefore be stored in a safe place to ensure that they are not lost.

- When sending parts in for repairs, they should be configured as follows:
 - (1) TRIFORCE:
 - Leave the key chip installed in the board.
 - (2) GD-ROM drive:
 - Remove the drive bracket.
 - Eject the GD-ROM disc, place it in its case, and store in a safe place.
- Remove the wire harnesses and cables from the TRIFORCE and GD-ROM drive before sending them in for repairs.
- Do not disassemble the TRIFORCE or GD-ROM drive. Place them in the carton box as is when sending them in for repairs.
- Provide a clear, detailed description of the game used and the observed problems when sending to the indicated repair center.

HOW TO USE THE TRIFORCE CARTON BOX

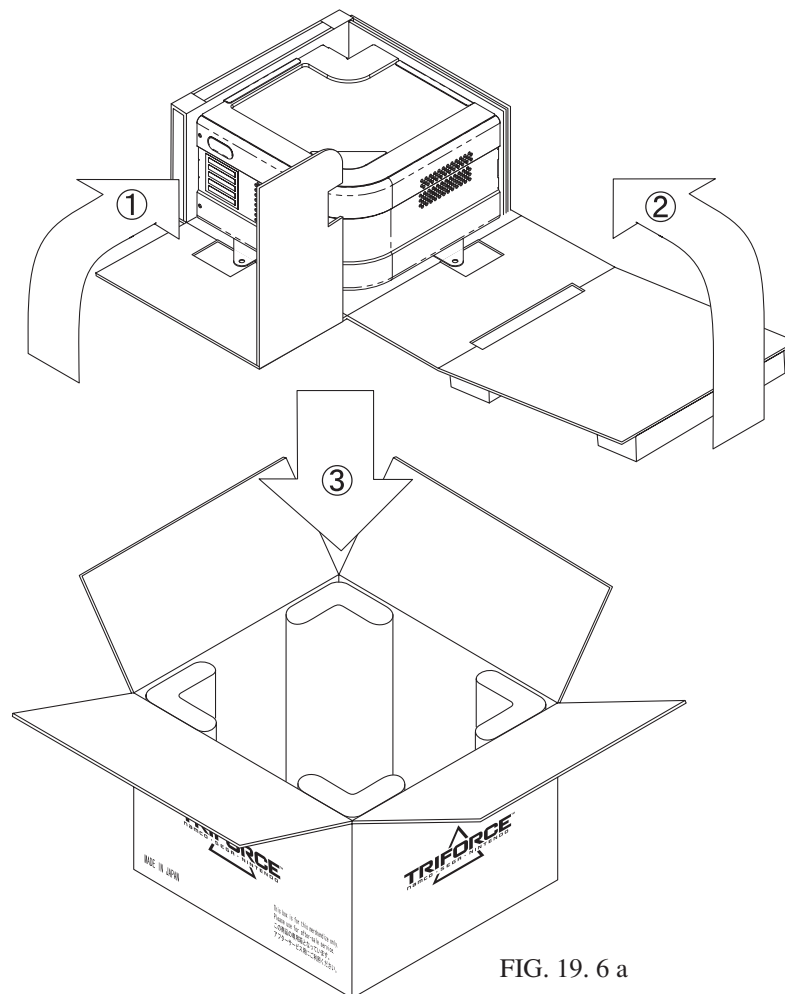

FIG. 19. 6 a

Fold the packaging in the order specified in the diagram and wrap it around the TRIFORCE, making sure that board and box are aligned correctly. Finally, place it in the carton box. Failure to wrap the product as specified in the diagram may cause damage to parts.

HOW TO USE THE CARTON BOX (GD-ROM DRIVE)



When you want to order for replacing or repairing service of the GD-ROM drive that is used by the product, pack it in a carton box as instructed below, and then deliver the carton box to a service agent. If you do not observe the instruction, your order may not be accepted or may be charged additionally. If you handle the GD-ROM drive differently from the following instructions, its components may be damaged.

- Contain the GD-ROM drive in a dedicated carton box. Do not disassemble it or remove any part from it unless otherwise instructed.
- Before containing the GD-ROM drive in a dedicated carton box, attach the GD-ROM drive lid (DISC LID) onto the drive and fix the lid with a screw.
- Before containing the GD-ROM drive in a dedicated carton box, remove the GD-ROM disc from the drive. Do not attempt to move the GD-ROM drive with a GD-ROM disc inside.
- Before containing the GD-ROM drive in a dedicated carton box, remove the GD-ROM drive bracket. Carefully keep the GD-ROM drive bracket and the 4 set screws, because they will be reused.
- When inserting the GD-ROM drive into a dedicated carton box, be careful about an inserting direction as illustrated below.
- The packing materials in a carton box are used as a cushion. Use them always when inserting the GD-ROM drive into a dedicated carton box. Do not bend them.

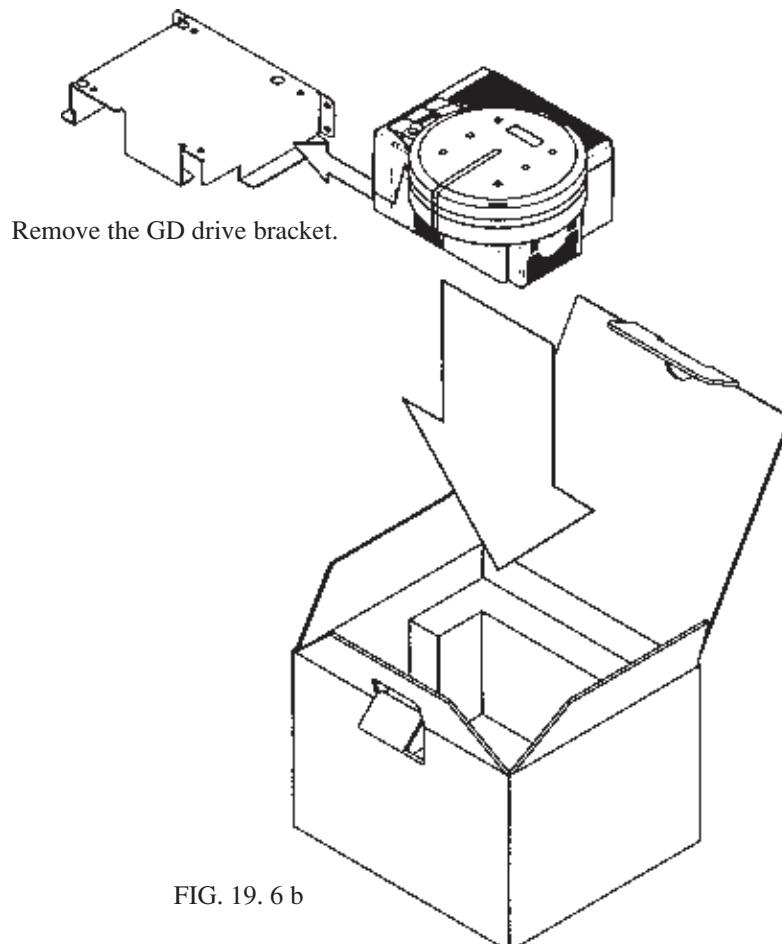
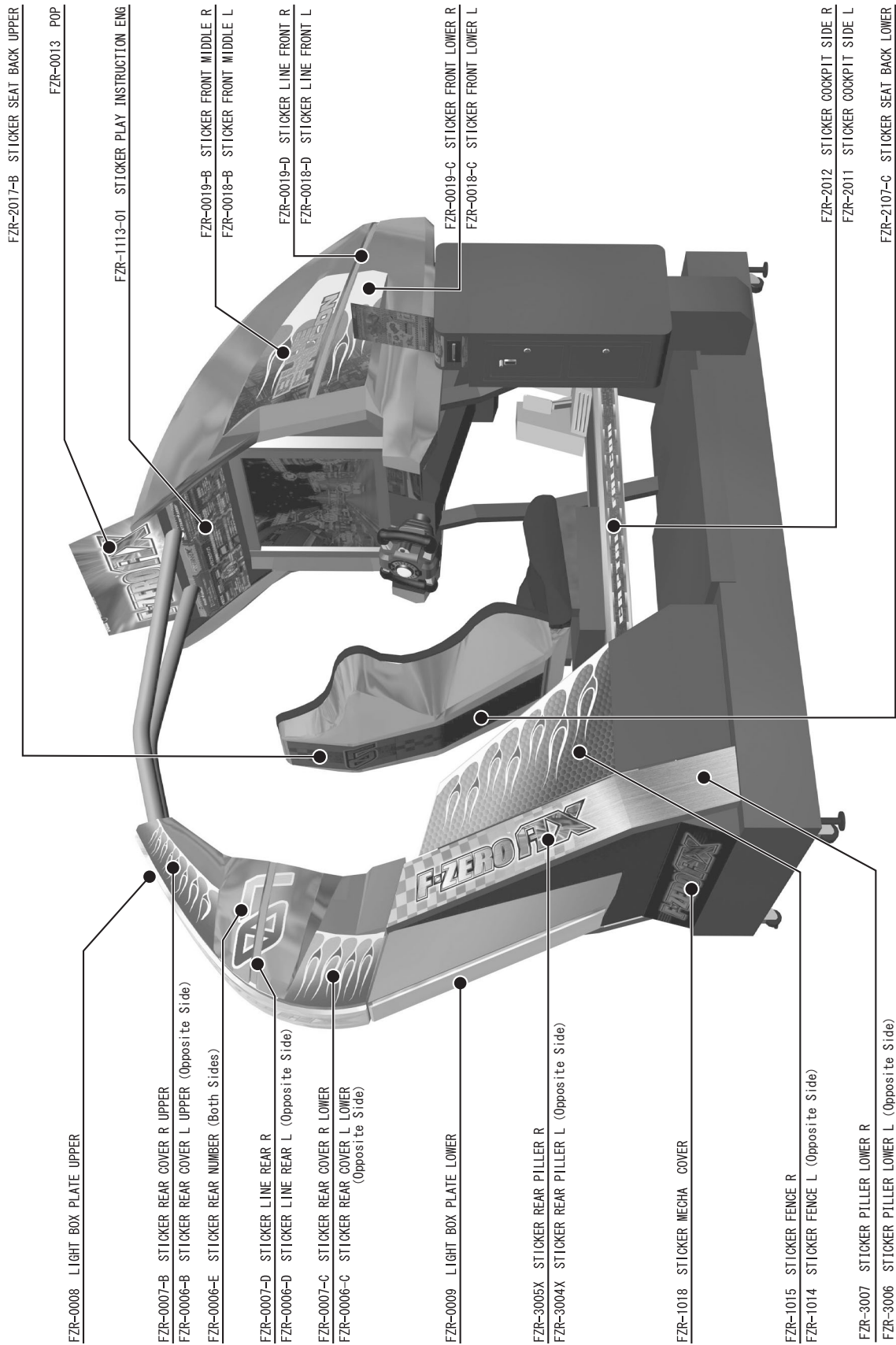
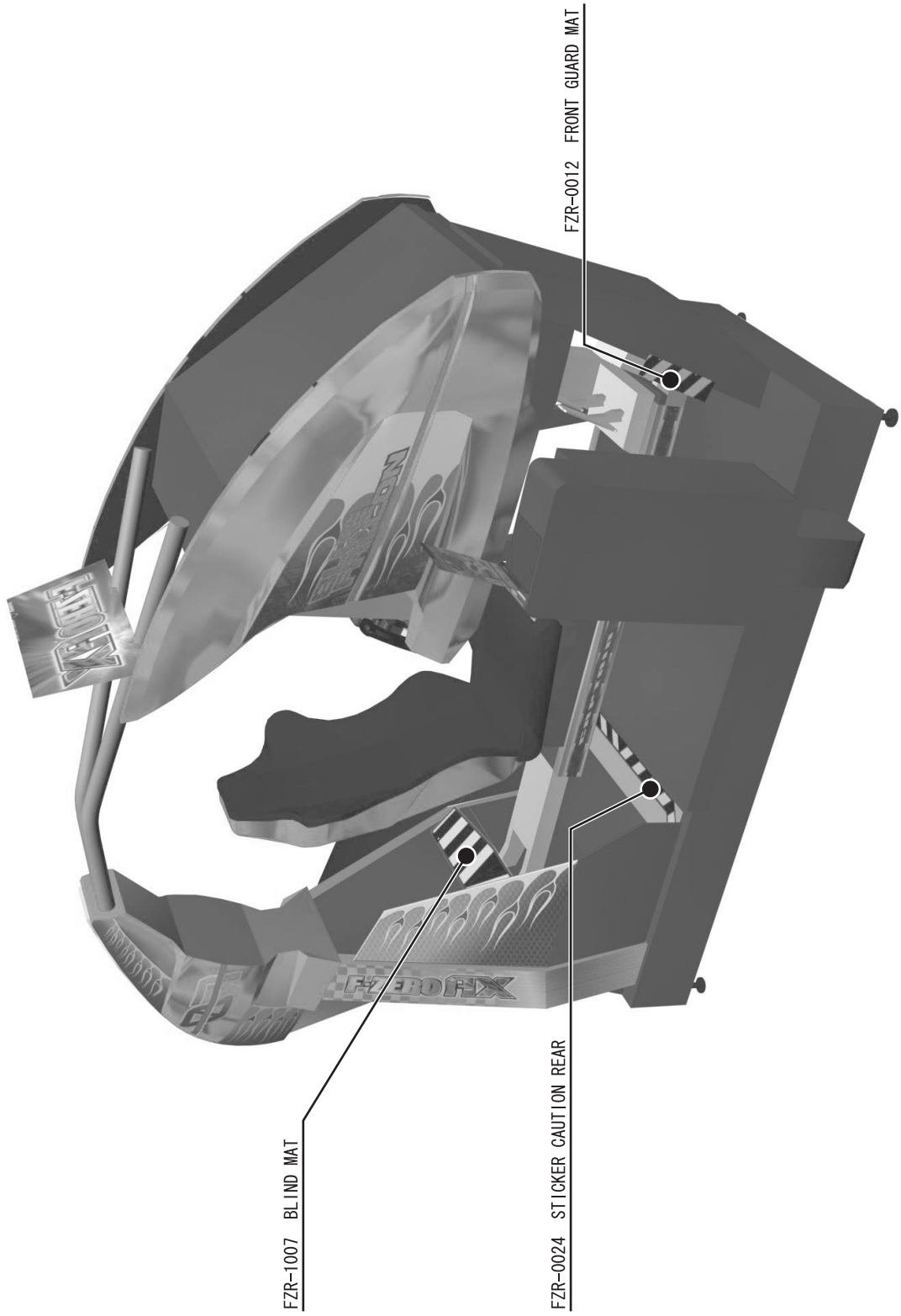

FIG. 19.6 b

20. DESIGN RELATED PARTS

For the warning display stickers, refer to Section 1.





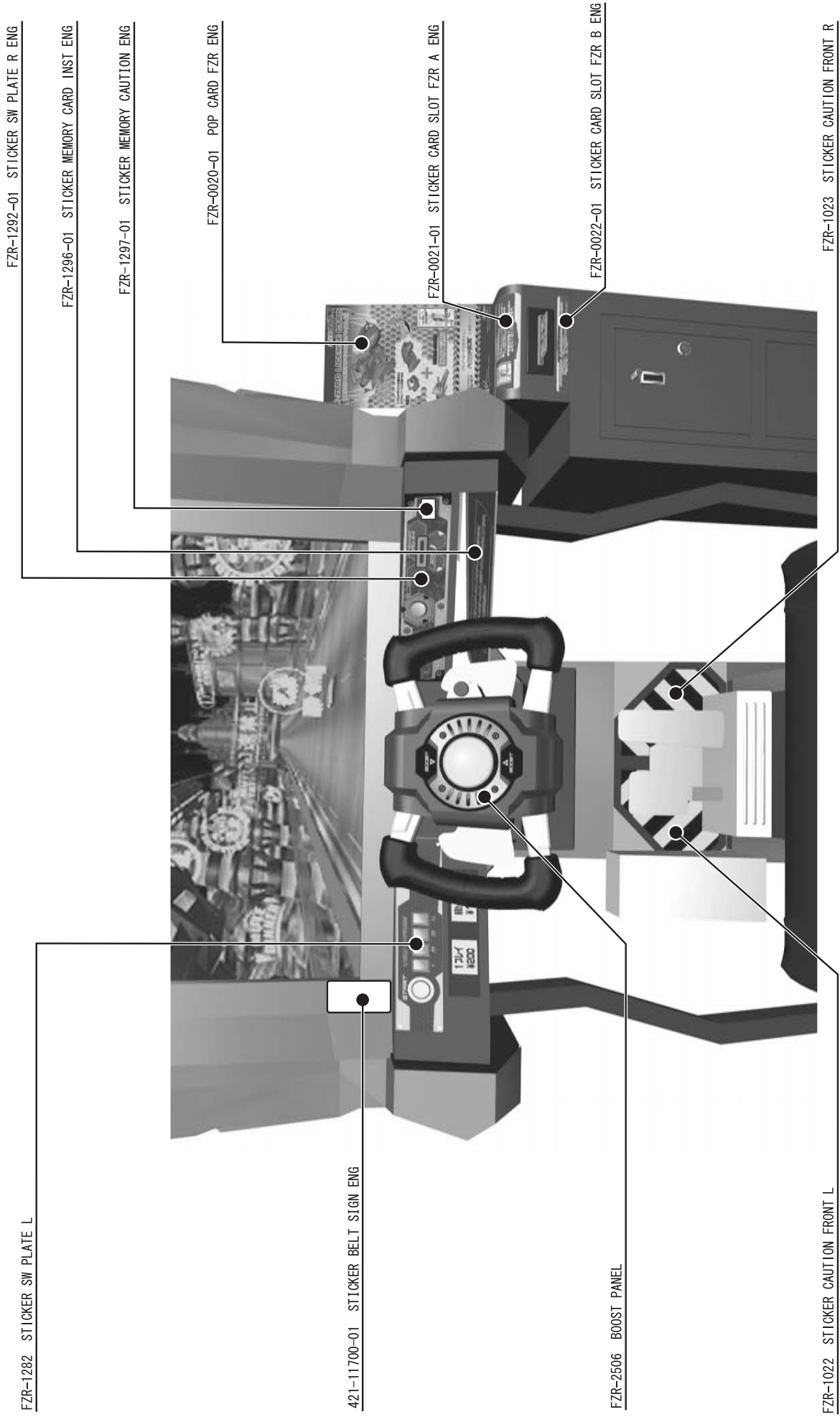

21. NETWORK PLAY

Up to 4 machines can be linked for network play. Properly connected network cables and correct network play settings are required for network play.

21 – 1 PRECAUTIONS REGARDING NETWORK PLAY SETUP



- Before starting to work, ensure that the Power SW is OFF. Failure to observe this can cause electric shock or short circuit.
- Use care so as not to damage wirings. Damaged wiring can cause electric shock or short circuit.
- Do not touch undesignated places. Touching places not designated can cause electric shock or short circuit.
- This work should be performed by the site maintenance individual or other skilled professional. Performing work by non-technical personnel can cause electric shock hazard.
- When linking a number of machines, be sure to supply sufficient power for the corresponding number of machines. Be sure to secure per machine current as stated in this manual. Failure to observe this can cause a fire and an electric shock accident.
- Due to the length of the network cable, the distance in between the machines is limited. However, to avoid accidents, be sure to secure space in excess of 70 cm between the machines.
- To perform work safely and avoid serious accident such as the cabinet's falling down, do not perform work in places where step-like grade differences, a ditch, or slope exist.



- To perform work safely, be sure to secure the space corresponding to number of machines to be linked. Failure to observe this can cause accident.
- To avoid accidents, use a cable cover that will not cause patrons to trip when laying network cables in areas of heavy foot traffic.
- To prevent accidents and acts of vandalism, cover the network cables with the strongest cover possible.



Network play is not possible between game machines with different cabinet types.

When connecting several games machines together, make sure that a sufficient amount of electrical power is available for each machine. Plan on providing 15A for each machine in 100-120V locations, and 7A in 220-240V locations.

SPACING OF GAME MACHINES

Leave at least 70 cm of space between game machines.

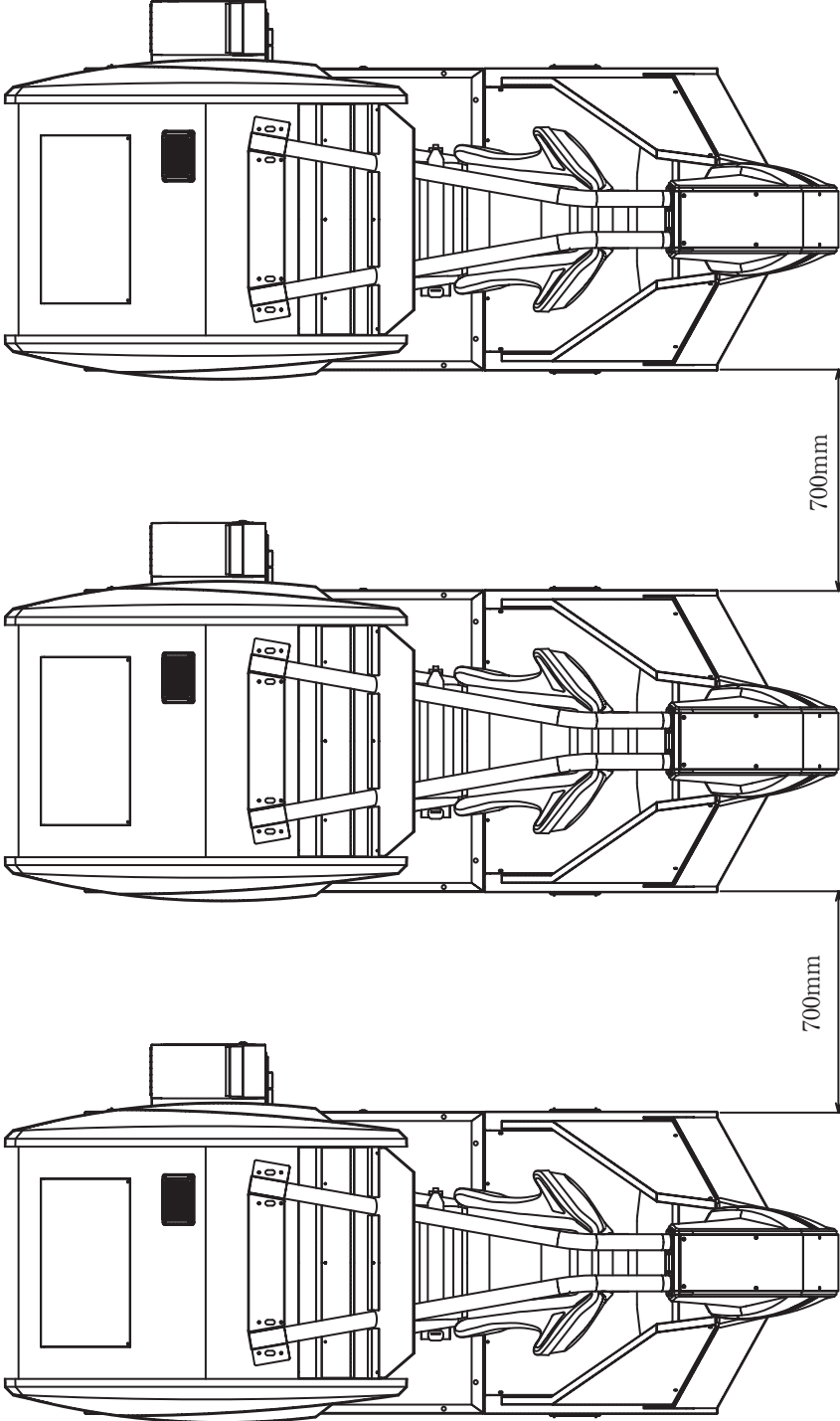

FIG. 21. 1

21 — 2 CONNECTING NETWORK CABLES

To enable network play, the hubs inside each of the game machines involved must be connected with network (LAN) cables. Connect the hub inside one of the machines to the hubs in each of the other machines using LAN cables. There is no need to connect the other machines to each other.

Do not connect LAN cables to game machines when they are not used for network play.

The following procedure requires the included LAN cables, the master key, a M4-size screwdriver, and a 24 mm diameter spanner.

- ① Turn off the power and unplug the power cord from the outlet. Place the power cord so as not to damage it while working.
- ② Using Section 8 of this manual as reference, move the machines so that they are lined up. Leave enough space on the front lid side of the machine to perform the rest of the operations in this procedure.
- ③ Remove the 6 truss screws securing the front lid to the front of the machine and then remove the lid.

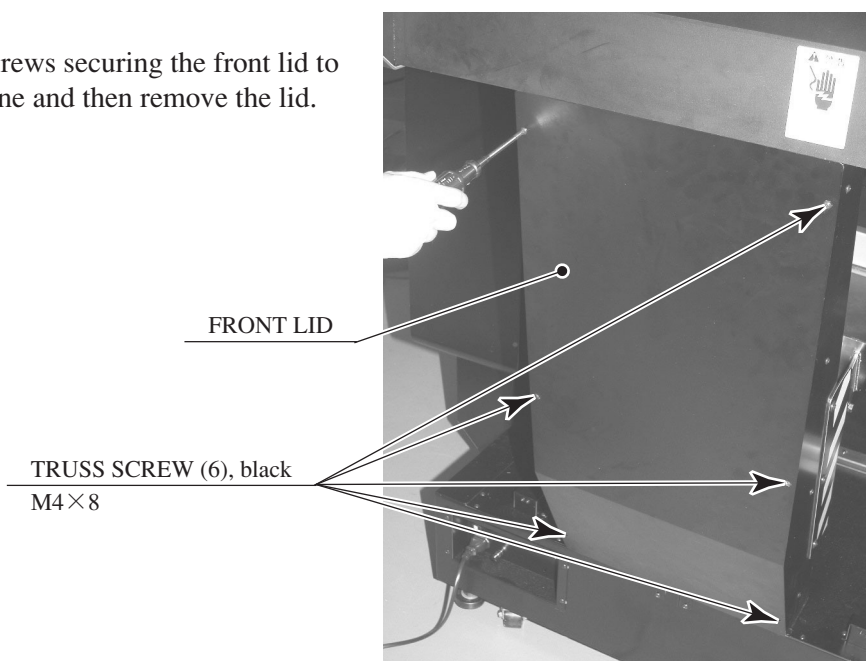

PHOTO 21. 2 a

- ④ Loosen 2 of the truss screws on the cable cover and shift the cover downward.

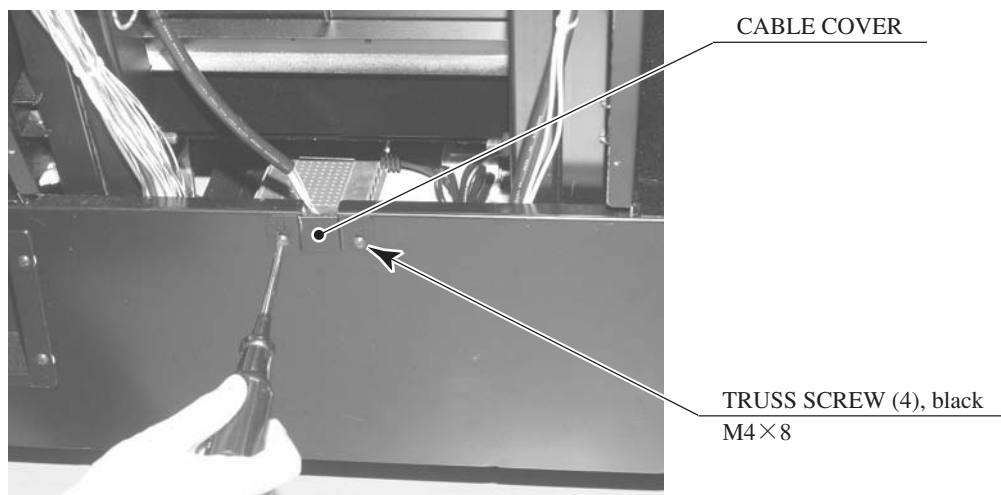

PHOTO 21. 2 b

- ⑤ Tighten the 2 loosened truss screws to secure the cable cover in place.

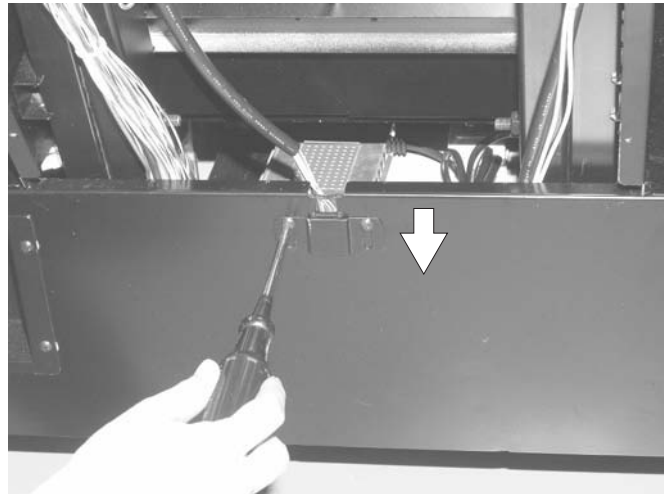

PHOTO 21. 2 c

- ⑥ Pass the LAN cable through the edge holder (the rectangular frame-shaped plastic part.) Pressing down on the edge holder from above will cause it to stretch elastically and open up.

EDGE HOLDER

LAN CABLE



PHOTO 21. 2 d

- ⑦ Plug the connector on the end of the LAN cable into port 2 or above on the hub. Port 1, located at the front closest to the front lid, is connected to the TRIFORCE in the base interior. Any of the ports 2 or above can be used to connect to any of the other game machines. Since the hub in one machine will be connected to the hubs in each of the other machines via LAN cables, only one machine needs to be fitted with enough LAN cables for all machines involved. The other machines will only have 2 cable connections each. *Note: In the photo, the front floor has been removed for better visibility. It does not need to be removed during the actual procedure.*

HUB

Connect to port 2 or above.

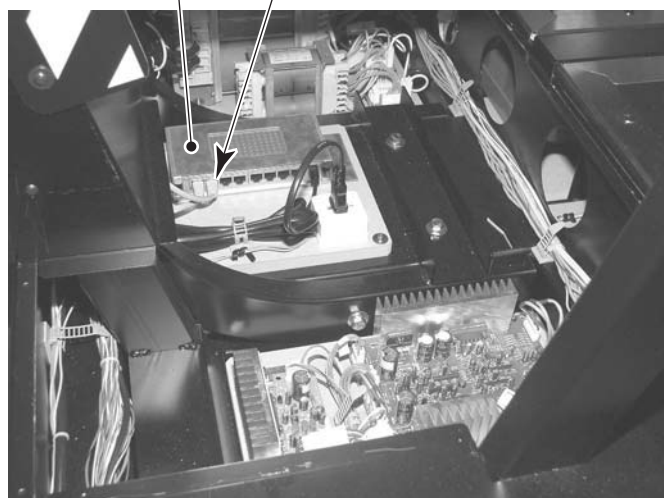
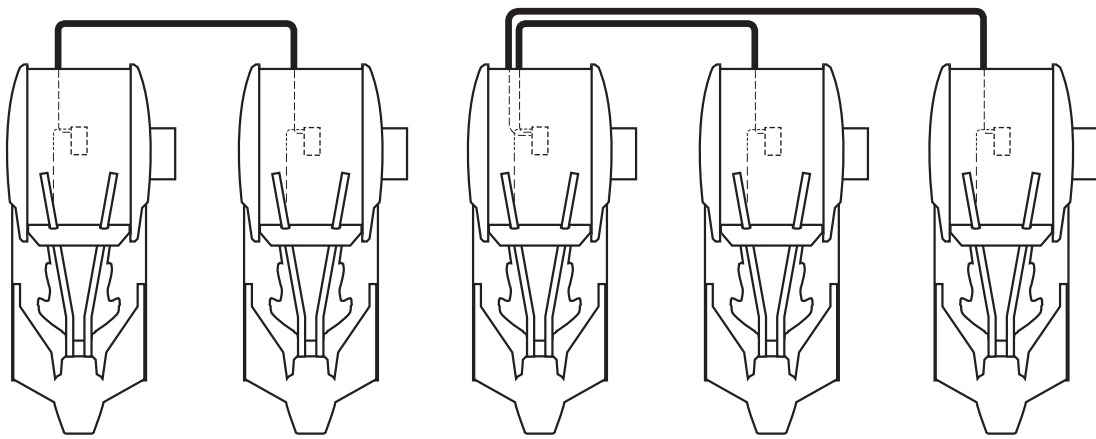
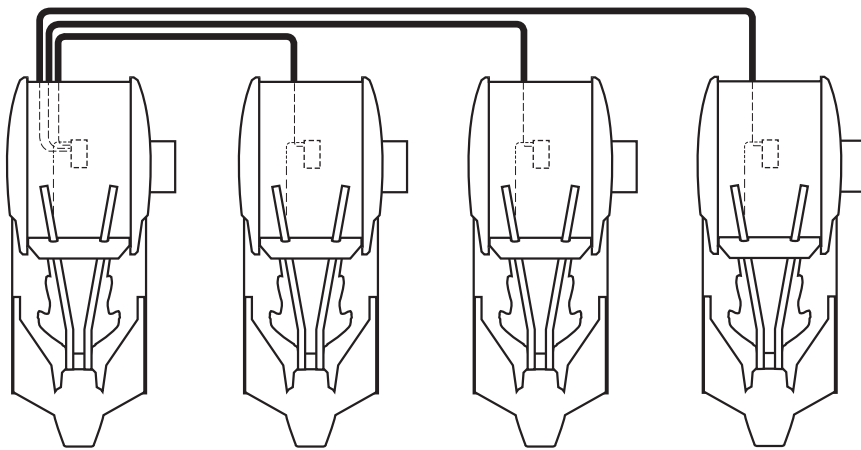

PHOTO 21. 2 e



2 machines linked together

3 machines linked together



4 machines linked together

FIG. 21. 2

- ⑧ Replace the front lid.
- ⑨ Once the machines have been linked for network play, line them up. Leave as much space as possible between the machines.
- ⑩ Secure all adjusters on each machine. (See 2 of Section 6.)
- ⑪ Connect the power cord and grounding wire for each machine. (See 4 of Section 6.)

21 — 3 NETWORK PLAY SETTINGS

Each of the linked machines must be set up for network play. If the machines are not set up correctly, network play will not be possible.

HOW TO SET UP A MACHINE FOR NETWORK PLAY

- ① Turn off the power on each machine to be used in network play.
- ② Enter Test mode on each machine. (See 10-2.)
- ③ Select GAME TEST MODE and press the TEST Button. The machine will enter Game Test mode and the screen will display the Game Test menu. (See 10-3.)
- ④ Select NETWORK SETTINGS from the Game Test menu and press the TEST Button. The Network Settings screen will appear. Network settings are carried out on this screen.

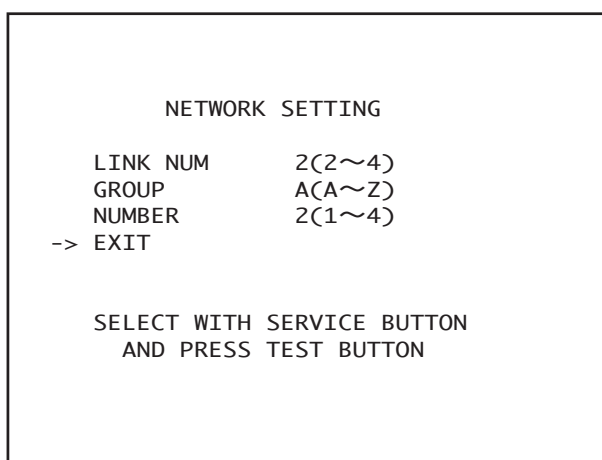

FIG. 21. 3

- ⑤ Set the LINK NUM setting on the Network Settings screen to the number of game machines linked for network play.
- ⑥ Set up the GROUP setting on the Network Settings screen. The GROUP setting is used to divide the machines linked for network play into groups. For example, a network of 4 machines could be divided into 2 groups of 2 machines.
- ⑦ Set the NUMBER setting on the Network Settings screen so that each machine within a group has a different number. Make sure that one machine in each group is set to "1".
- ⑧ Exit Test mode on each machine. Be sure to choose EXIT from the System Test Menu to exit Test mode properly.
- ⑨ Once each machine has exited Test mode and gone through initialization, it will begin a network test. During the network test, the monitor will display a network test screen. If there are no problems with network play settings or cable connections, the machine will enter Advertising mode.
- ⑩ If the advertising screen appears after the network test is finished, network settings are complete.
The network test should last roughly 20 to 30 seconds. If the network test screen fails to disappear, the problem is most likely due to one of the following: incorrect settings, an improperly connected LAN cable, a faulty LAN cable connection, or a severed wire.



- When setting up machines for network play, settings such as the game's difficulty level will be derived from the machine whose "NUMBER" is set to "1". If settings on machine "1" are changed, the other machines will have their settings changed accordingly. On machines other than "1", settings derived from machine "1" will not be displayed on screen and cannot be changed.
- Should a network connection fail during network play, gameplay will be suspended and the Network Error Screen will be displayed.
- If one of the units attached for network play enters Test Mode, the other unit will display the same Test Mode Screen.
- Even when units are connected for network play, each seat, each game may be given different cost settings. Incorrect cost settings may cause budget balancing problems.

Note that when 2 or more machines are linked together for network play, some functions are different than for stand-alone machines.

Whenever Test mode is used on a machine linked for network play, all machines connected to the network will display the network test screen. When patrons are engaged in network play, do not enter Test mode on any of the machines in the network, even if the machine is not in use. However, machines whose GROUP setting is different from that of the machine entering Test mode will not be affected.

22. PARTS LIST

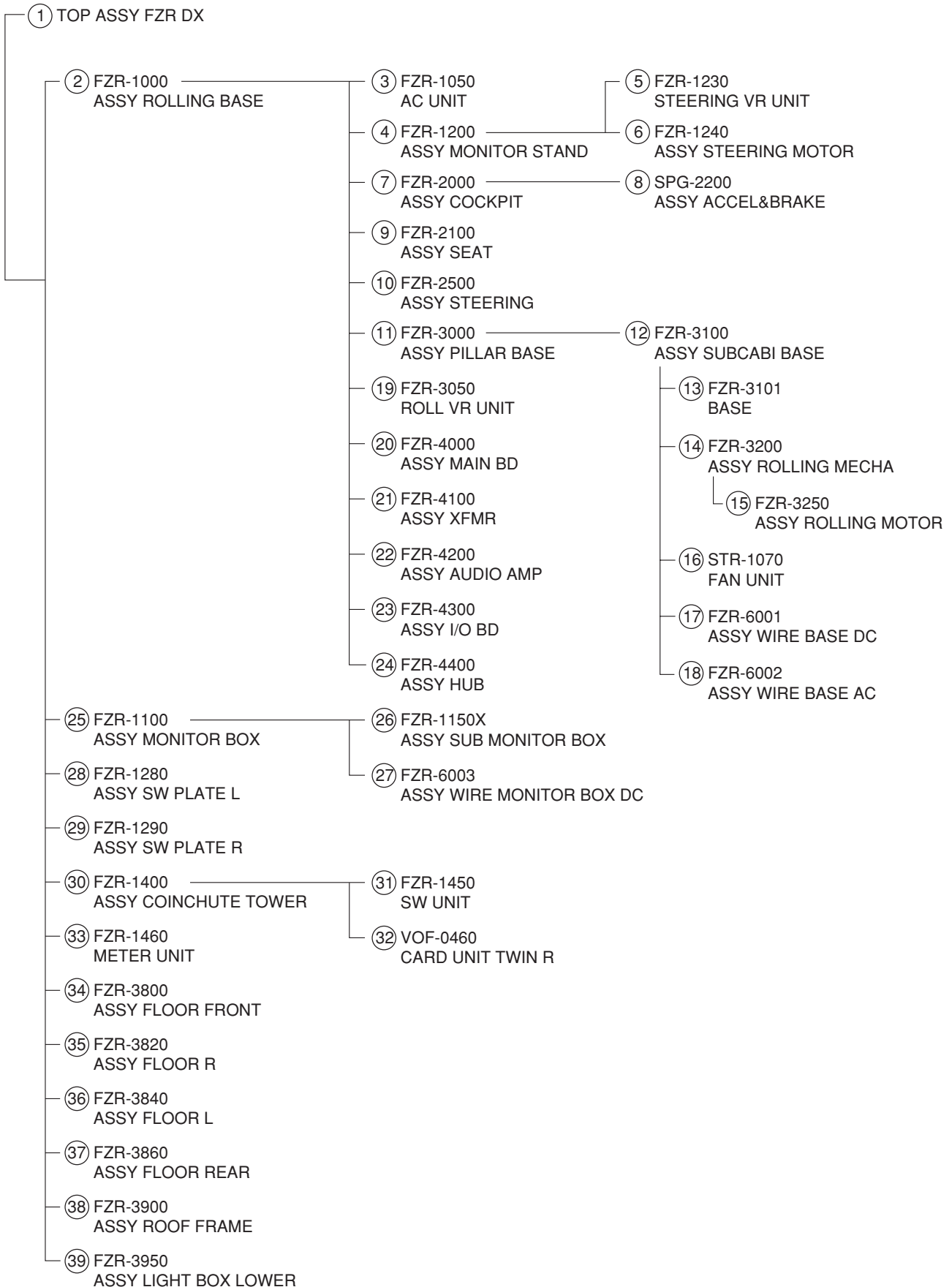

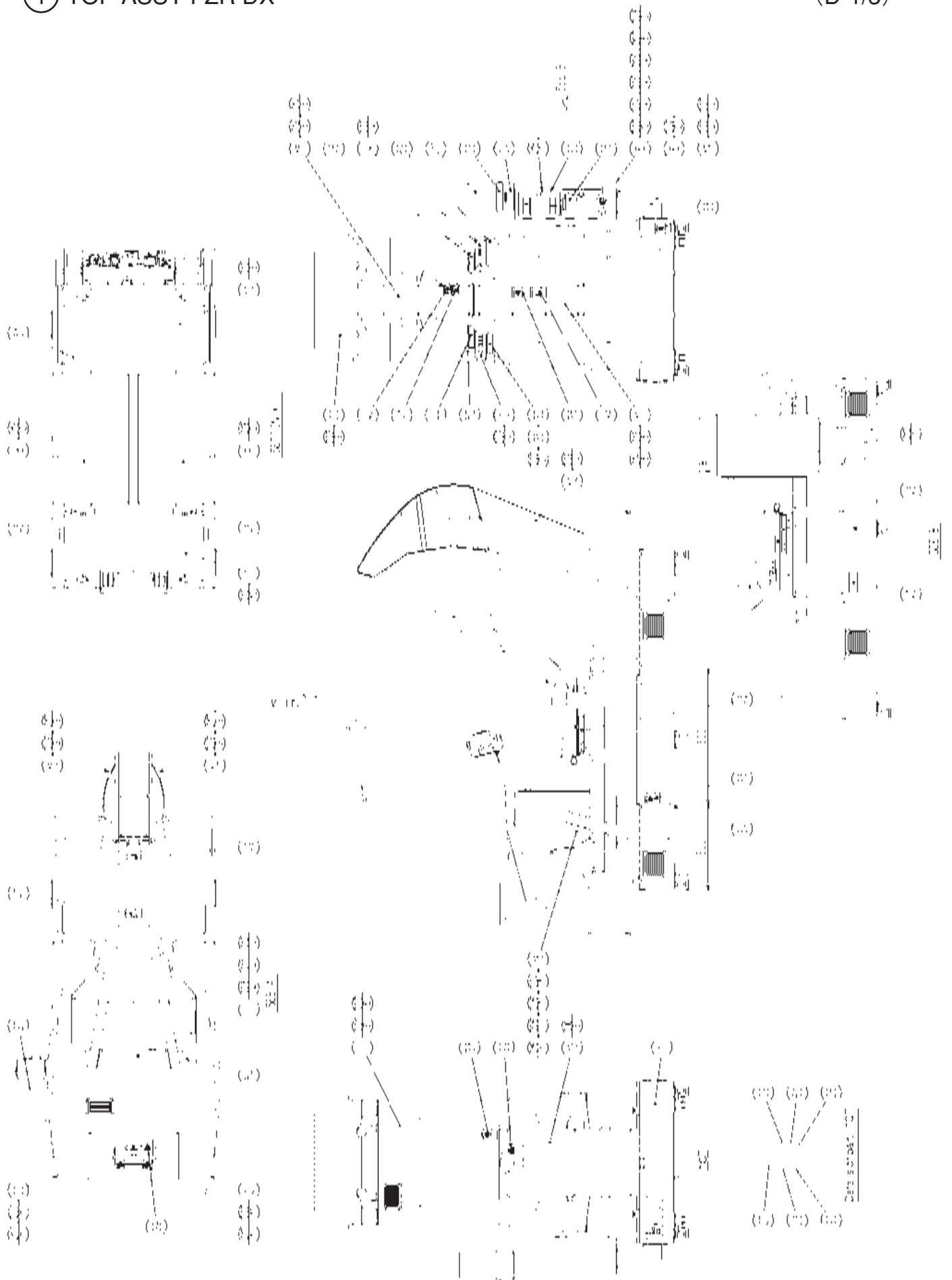

① TOP ASSY FZR DX

(D-2/3)

ITEM NO.	PART NO.	DESCRIPTION	NOTE
1	FZR-1000	ASSY ROLLING BASE	
2	FZR-1100	ASSY MONITOR BOX	
3	FZR-1280	ASSY SW PLATE L	
4	FZR-1290	ASSY SW PLATE R	
5	FZR-1400	ASSY COINCHUTE TOWER	
6	FZR-1460	METER UNIT	
7	FZR-3800	ASSY FLOOR FRONT	
8	FZR-3820	ASSY FLOOR R	
9	FZR-3840	ASSY FLOOR L	
10	FZR-3860	ASSY FLOOR REAR	
11	FZR-3900	ASSY ROOF FRAME	
12	FZR-3950	ASSY LIGHT BOX LOWER	
13	FZR-0005	FRONT LID	
14	FZR-0006	REAR SIDE COVER L	
15	FZR-0007	REAR SIDE COVER R	
16	FZR-0008	LIGHT BOX PLATE UPPER	
17	FZR-0009	LIGHT BOX PLATE LOWER	
18	FZR-0010	TOWER HOLDER	
19	FZR-0011	TOWER BASE	
20	FZR-0013	POP	
21	FZR-0018	FRONT SIDE COVER L	
22	FZR-0019	FRONT SIDE COVER R	
23	FZR-0021-01	STICKER CARD SLOT FZR A ENG	
24	FZR-0022-01	STICKER CARD SLOT FZR B ENG	
25	253-5366	CASH BOX	
31	421-8479-01	STICKER INSTR SUNLIGHT ENG	
32	JEY-0005	DENOMI PLATE	
33	SGM-4531	POLY COVER 1000 × 2400 × 2000	
34	421-11416	STICKER CAUTION FORK	
37	CKT-0015	STICKER CARD STOCKER	
38	440-WS0002XEG	STICKER W POWER OFF ENG	
39	440-CS0140-JP	STICKER C GEAR	
40	440-WS0033XEG	STICKER W BD POWER OFF ENG	
41	440-WS0141-EG	STICKER W HIGH TEMP S ENG	
42	440-WS0142-EG	STICKER W POWER OFF S ENG	
43	440-WS0012XEG	STICKER W HIGH TEMP ENG	
44	440-CS0276-EG	STICKER C PLAYER RESTRICTIONS	
45	440-CS0277-EG	STICKER C EPILEPSY 35 ENG	
46	440-CS0278-EG	STICKER C BAGGAGE ENG	
47	440-CS0279-EG	STICKER C KEEP OUT ENG	
48	440-CS0280-EG	STICKER C NOT APPROACH ENG	
49	440-WS0275-EG	STICKER W PINCH ENG	
51	FZR-0024	STICKER CAUTION REAR	
52	421-11700-01	STICKER BELT SIGN ENG	
53	FZR-1296-01	STICKER MEMORY CARD INST ENG	
54	SLC-0006	FLAT WASHER 8.4-25 × 2	

① TOP ASSY FZR DX

(D-3/3)

ITEM NO.	PART NO.	DESCRIPTION	NOTE
201	030-000880-SB	HEX BLT W/S BLK M8 × 80	
202	068-852216-0B	FLT WSHR BLK 8.5-22 × 1.6	
203	000-T00410-0B	M SCR TH BLK M4 × 10	
204	050-H00600	HEX NUT M6	
205	060-S00600	SPR WSHR M6	
206	068-652016	FLT WSHR 6.5-20 × 1.6	
207	030-000820-SB	HEX BLT W/S BLK M8 × 20	
208	030-000850-SB	HEX BLT W/S BLK M8 × 50	
209	000-P00410-W	M SCR PH W/FS M4 × 10	
210	000-T00408-0B	M SCR TH BLK M4 × 8	
211	050-H00800	HEX NUT M8	
212	060-S00800	SPR WSHR M8	
213	000-T00408-0C	M SCR TH CRM M4 × 8	
214	068-441616-0C	FLT WSHR CRM 4.4-16 × 1.6	
215	031-000650-0B	CRG BLT BLK M6 × 50	
216	008-T00412-0B	TMP PRF SCR TH BLK M4 × 12	
217	068-441616-0B	FLT WSHR BLK 4.4-16 × 1.6	
401	601-6604-70	CARTON BOX 70	
402	220-5484	VOL CONT B-5K OHM	
	220-5753	VOL CONT B-5K OHM (TOCOS)	
403	220-5576	KEY MASTER FOR 220-5575	
404	SGM-4111Y	KEY BAG	
405	514-5036-10000	FUSE 6.4 × 30 10000MA 125V	
406	600-7269-1000	ASSY LAN CABLE 1000CM	
407	600-6729	AC CABLE CONNECT TYPE 15A	<Taiwan>
	600-7228	AC CABLE CONNECT TYPE 15A	<Taiwan>
	600-6695-01	AC CABLE CONNECT TYPE USA 15A	<USA>
	600-6619-01	AC CABLE CONNECT TYPE FOR UK	<Hong Kong>
	600-6618	AC CABLE CONNECT TYPE FOR EXP	<Others>
408	280-5009-01	CORD CLAMP 21	
409	601-11050	CLEANING KIT	
410	420-6769-01	OWNERS MANUAL FZR DX ENG	
411	105-5435	GD DRIVE BRKT STD	
412	000-P00416-W	M SCR PH W/FS M4 × 16	
413	012-P00408	TAP SCR #2 PH 4 × 8	
414	600-7247-500	CABLE SCSI ST-L TYPE2 500MM	
415	610-0650-0007	GD SOFT KIT FZR ASIA	<Asia>
	610-0650-0004	GD SOFT KIT FZR	<Others>
417	FZR-0020-01	POP CARD FZR ENG	
418	SGM-2675X	POLYETHYLENE BAG 240 × 370	
419	600-6664-02	WIRE HARN EARTH W/LUG M6	<Taiwan>
		NOT USED	<Others>
422	220-5775	VOL CONT B-10K OHM W/BD	
423	509-6036	SW MICRO MATSUSHITA AM51615A7	
/	421-6690-01	STICKER 120V	<AC 120V Area>
/	421-6690-06	STICKER 110V	<AC 110V Area>
/	421-6690-03	STICKER 220V	<AC 220V Area>
/	421-6690-05	STICKER 240V	<AC 240V Area>
/	421-6690-04	STICKER 230V	<AC 230V Area>
/	421-6119-91	STICKER FCC	<USA>
/	421-6120-93	STICKER SEGA USA	<USA>

② ASSY ROLLING BASE (FZR-1000)

(D-1/3)

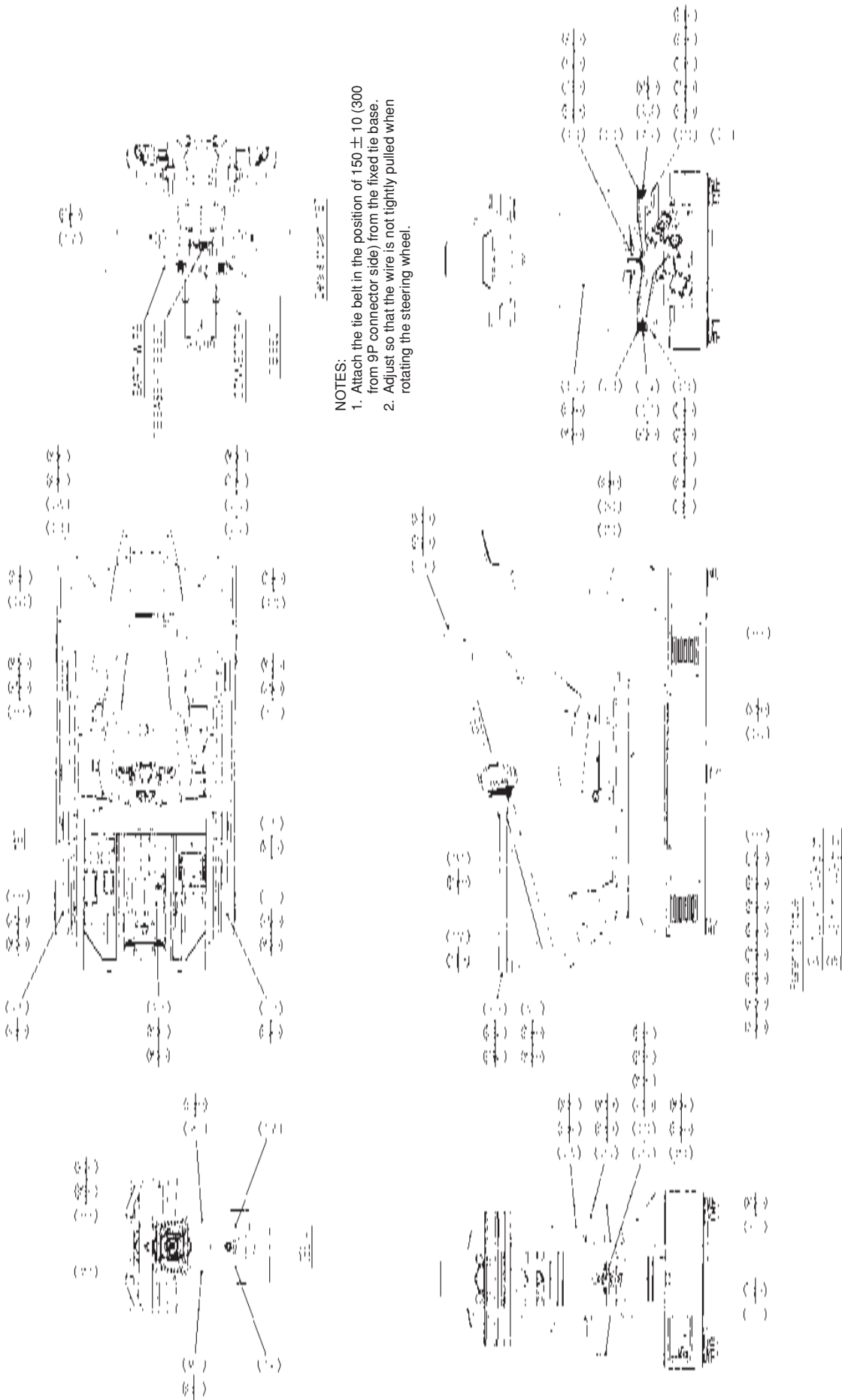

② ASSY ROLLING BASE (FZR-1000)

(D-2/3)

ITEM NO.	PART NO.	DESCRIPTION	NOTE
1	FZR-1050	AC UNIT	
2	FZR-1200	ASSY MONITOR STAND	
3	FZR-2000	ASSY COCKPIT	
4	FZR-2100	ASSY SEAT	
5	FZR-2500	ASSY STEERING	
6	FZR-3000	ASSY PILLAR BASE	
7	FZR-3050	ROLL VR UNIT	
8	FZR-4000	ASSY MAIN BD	
9	FZR-4100	ASSY XFMR	
10	FZR-4200	ASSY AUDIO AMP	
11	FZR-4300	ASSY I/O BD	
12	FZR-4400	ASSY HUB	
13	FZR-0001	FRONT SIDE SASH L	
14	FZR-0002	FRONT SIDE SASH R	
15	FZR-0003	FRONT COVER L	
16	FZR-0004	FRONT COVER R	
17	FZR-0012	FRONT GUARD MAT	
18	FZR-0014	HANDLE SPACER RING	
19	FZR-0015	CTRL PNL PLATE CENTER	
20	FZR-1001	BELT CLAMP	
21	FZR-1002	IDLER PULLEY S8M 22	
22	FZR-1003	IDLER COLLAR	
23	FZR-1004	IDLER SUPPORT	
24	FZR-1005	PILLAR LID UPPER	
25	FZR-1006	PILLAR LID LOWER	
26	FZR-1007	BLIND MAT	
27	FZR-1008	REAR PILLAR PANEL	
28	FZR-1009	MECHA COVER	
29	FZR-1010	REAR SIDE SASH L	
30	FZR-1011	REAR SIDE SASH R	
31	FZR-1012	FENCE L	
32	FZR-1013	FENCE R	
33	FZR-1014	STICKER FENCE L	
34	FZR-1015	STICKER FENCE R	
35	FZR-1018	STICKER MECHA COVER	
36	FZR-2009	COCKPIT MAT HOLDER	
37	FZR-2010	COCKPIT LOWER COVER	
38	TTR-2010	GEAR HOLDER 110	
39	601-6450	GEAR 110	
40	FZR-1019	WIRE HOLDER	
41	FZR-1022	STICKER CAUTION FRONT L	
42	FZR-1023	STICKER CAUTION FRONT R	
43	FZR-2004	COCKPIT FRONT COVER	
101	601-11313	TIMING BELT 300 S8M 2152 OPEN	
102	100-5112	BEARING 17 (NSK 6003ZZ)	
103	280-5257	TIE BASE TA158	
104	601-0460	PLASTIC TIE BELT 100MM	

② ASSY ROLLING BASE (FZR-1000)

(D-3/3)

ITEM NO.	PART NO.	DESCRIPTION	NOTE
201	000-T00408-0B	M SCR TH BLK M4 × 8	
202	030-000880-SB	HEX BLT W/S BLK M8 × 80	
203	068-852216-0B	FLT WSHR BLK 8.5-22 × 1.6	
204	FAS-200005	HEX SKT H CAP SCR B OZ M14 × 40	
205	060-S01400	SPR WSHR M14	
206	060-F01400	FLT WSHR M14	
207	030-000825-S	HEX BLT W/S M8 × 25	
208	060-F00800	FLT WSHR M8	
209	050-H01000	HEX NUT M10	
210	060-S01000	SPR WSHR M10	
211	060-F01000-0B	FLT WSHR BLK M10	
212	030-0008A0-S	HEX BLT W/S M8 × 100	
213	000-P00408-W	M SCR PH W/FS M4 × 8	
214	000-P00416-W	M SCR PH W/FS M4 × 16	
215	068-441616-0B	FLT WSHR BLK 4.4-16 × 1.6	
216	000-P00425-W	M SCR PH W/FS M4 × 25	
217	000-T00410-0B	M SCR TH BLK M4 × 10	
218	030-001020-SB	HEX BLT W/S M10 × 20	
219	FAS-650018	STP RING BLK OZ H35	
220	050-H01200	HEX NUT M12	
221	060-S01200	SPR WSHR M12	
222	060-F01200	FLT WSHR M12	
223	000-F00310	M SCR FH M3 × 10	
225	000-T00408-0C	M SCR TH CRM M4 × 8	
226	000-P00410-S	M SCR PH W/S M4 × 10	
227	028-A00408-P	SET SCR HEX SKT CUP P M4 × 8	
228	000-P00408	M SCR PH M4 × 8	
229	060-S00400	SPR WSHR M4	
230	060-F00400	FLT WSHR M4	
231	050-H00400	HEX NUT M4	
232	000-P00305-S	M SCR PH W/S M3 × 5	
233	000-P00508	M SCR PH M5 × 8	
234	060-S00500	SPR WSHR M5	
235	060-F00500	FLT WSHR M5	
301	600-6972-0300	WIRE HARN EARTH ID5 0300MM	

③ AC UNIT (FZR-1050)

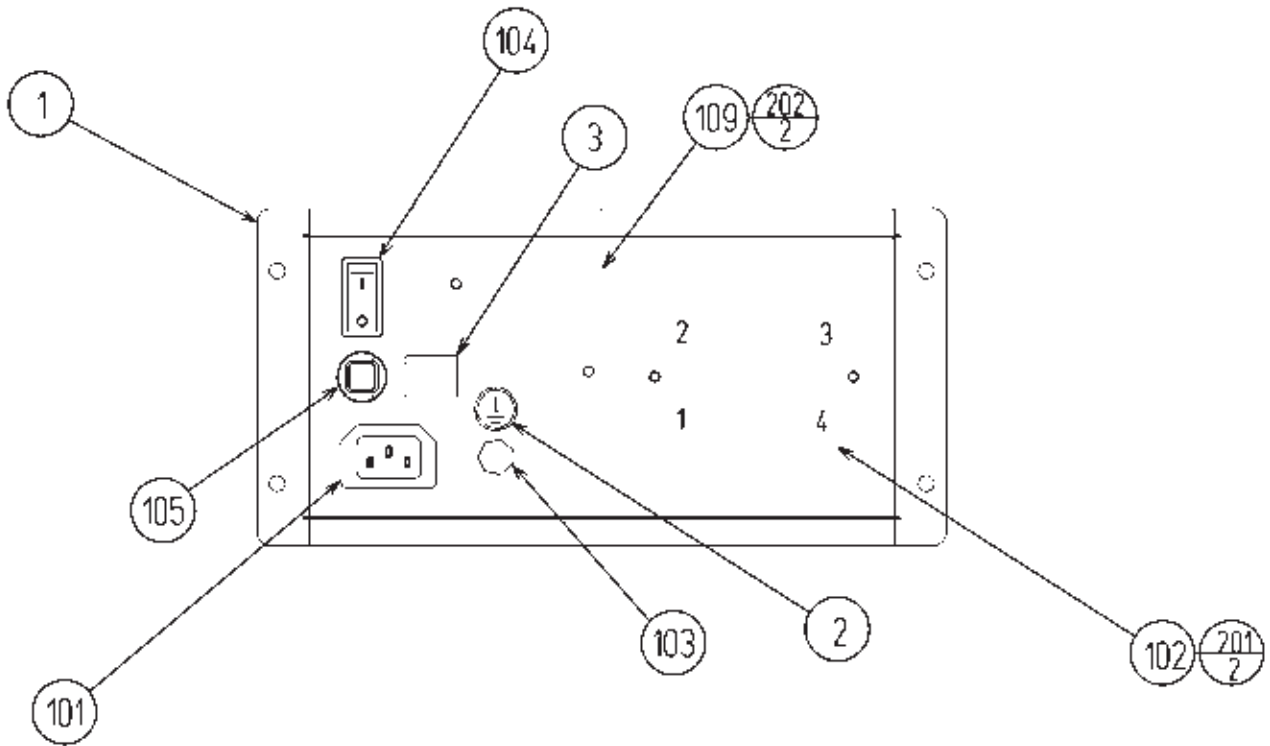

ITEM NO.	PART NO.	DESCRIPTION	NOTE
1	FZR-1051	AC BRKT	
2	421-8202	STICKER EARTH MARK	
3	421-7468-02	STICKER C.P W/PIC	
101	214-0202	AC INLET PANEL TYPE	
102	270-5081	NOISE FILTER 20A	
103	280-0417	TERMINAL BINDING POST BLACK	<Taiwan>
		NOT USED	<Others>
104	509-5453-91-V-B	SW ROCKER J8 V-B	
105	512-5046-10000	C.P 10000MA CE UL	<AC 110 - 120V Area>
	512-5046-5000	C.P 5000MA CE UL	<AC 220 - 240V Area>
106	601-0460	PLASTIC TIE BELT 100 MM	
107	310-5029-F20	SUMITUBE F F 20MM	
108	310-5029-G20	SUMITUBE F G 20MM	
109	450-5126	MAGNET CONTACT S-NIOCX	<Taiwan>
	450-5135	MAGNET CONTACT S-NIOCX AC 120V	<USA>
	450-5133	MAGNET CONTACT S-NIOCX AC 200V	<Korea>
	450-5134	MAGNET CONTACT S-NIOCX AC 230V	<Others>
201	000-P00408-W	M SCR PH W/FS M4 × 8	
202	000-P00416-W	M SCR PH W/FS M4 × 16	
203	060-S00400	SPR WSHR M4	
204	060-F00400	FLT WSHR M4	
205	050-H00400	HEX NUT M4	
301	FZR-60019	WH AC UNIT01	
302	FZR-60020	WH AC UNIT02	
303	FZR-60021	WH AC UNIT03	
304	FZR-60022	WH AC UNIT04	

④ ASSY MONITOR STAND (FZR-1200)

(D-1/2)

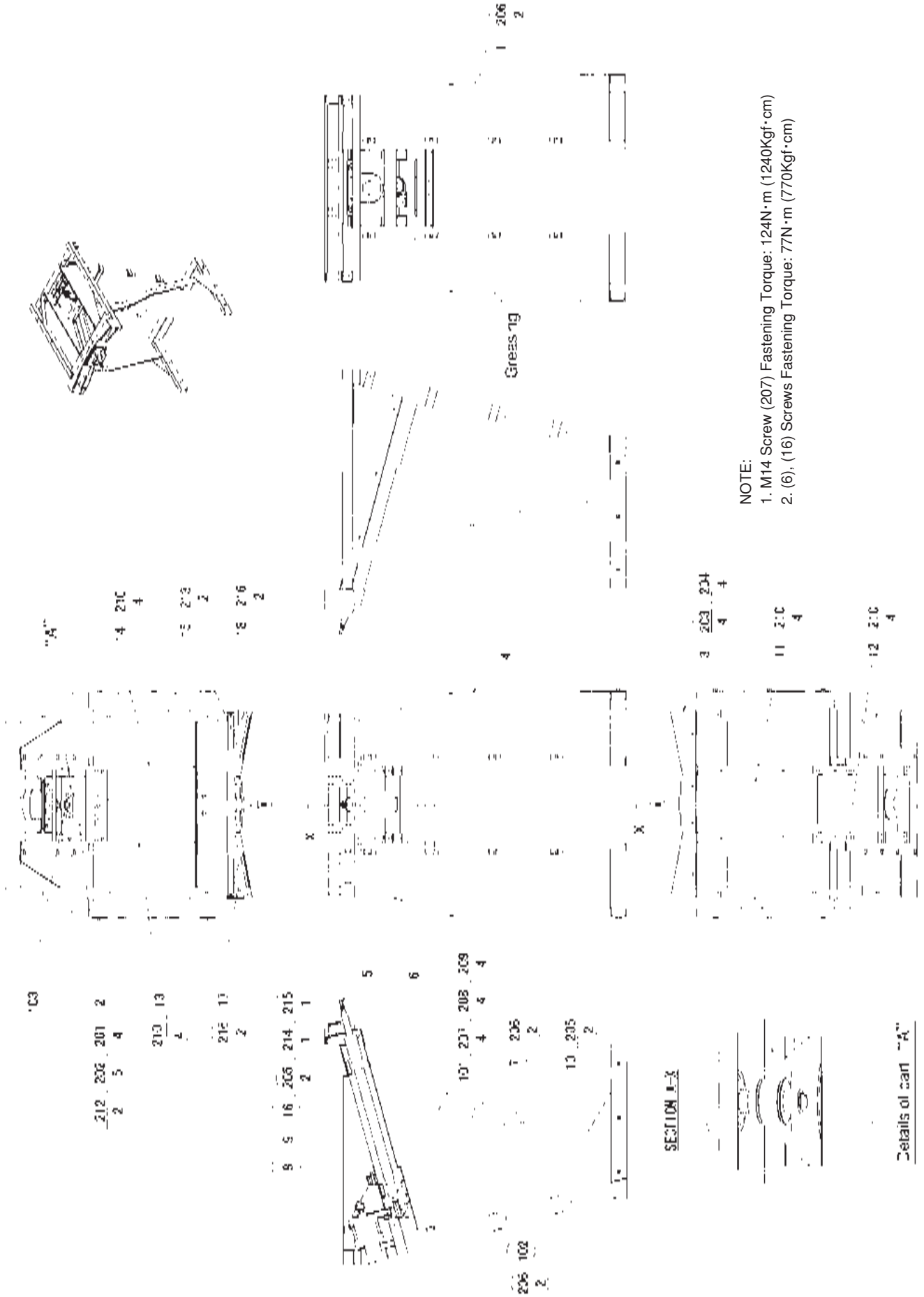

④ ASSY MONITOR STAND (FZR-1200)

(D-2/2)

ITEM NO.	PART NO.	DESCRIPTION	NOTE
1	FZR-1230	STEERING VR UNIT	
2	FZR-1240	ASSY STEERING MOTOR	
3	FZR-1261	CONTROL PANEL COVER	
4	FZR-1201	MONITOR STAND	
5	FZR-1202	HANDLE SHAFT FZR	
6	FZR-1203	HANDLE EXTENSION COLLAR	
7	FZR-1204	STEERING VR BASE	
8	SPG-2505	PULLEY 60 S5M	
9	DYN-1270	STOPPER KEY	
10	SLC-1130	ADJUST RING	
11	FZR-1205	SHAFT COVER LOWER	
12	FZR-1206	MOTOR COVER LOWER	
13	FZR-1211	UNDER SIDE COVER L	
14	FZR-1212	UNDER SIDE COVER R	
15	FZR-1209	CONTROL PANEL BEAM	
16	FZR-1210	HANDLE EXTENSION SHAFT	
17	FZR-1213	CONTROL PANEL STAY L	
18	FZR-1214	CONTROL PANEL STAY R	
101	100-5436	BEARING 30 (NTN UCUP206)	
102	601-6172	GEAR 48	
103	601-9173	TIMING BELT (150 S5M 475)	
201	030-000860-SB	HEX BLT W/S BLK M8 × 60	
202	068-852216-0B	FLT WSHR BLK 8.5-22 × 1.6	
203	000-T00410-0B	M SCR TH BLK M4 × 10	
204	068-441616-0B	FLT WSHR BLK 4.4-16 × 1.6	
205	028-A00408-P	SET SCR HEX SKT CUP P M4 × 8	
206	000-P00408-W	M SCR PH W/FS M4 × 8	
207	FAS-200049	HEX SKT H CAP SCR B 0Z M14 × 25	
208	060-S01400	SPR WSHR M14	
209	060-F01400	FLT WSHR M14	
210	000-P00408-WB	M SCR PH W/FS BLK M4 × 8	
212	050-H00800	HEX NUT M8	
213	000-F00408	M SCR FH M4 × 8	
214	060-S01200	SPR WSHR M12	
215	060-F01200	FLT WSHR M12	
216	000-P00512-WB	M SCR PH W/FS BLK M5 × 12	

⑤ STEERING VR UNIT (FZR-1230)

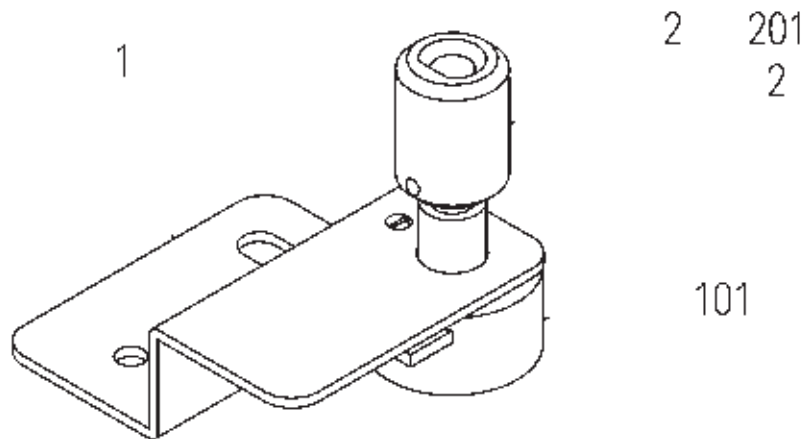

ITEM NO.	PART NO.	DESCRIPTION	NOTE
1	FZR-1231	STEERING VR BRKT	
2	601-7945	GEAR 20	
101	220-5484	VOL CONT B-5K OHM	
101	220-5753	VOL CONT B-5K OHM (TOCOS)	
102	310-5029-F20	SUMITUBE F F 20MM	
201	028-A00306-P	SET SCR HEX SKT CUP P M3 × 6	
301	600-6866	WIRE HARN ASSY HANDLE MECHA VR	

⑥ ASSY STEERING MOTOR (FZR-1240)

(D-1/2)

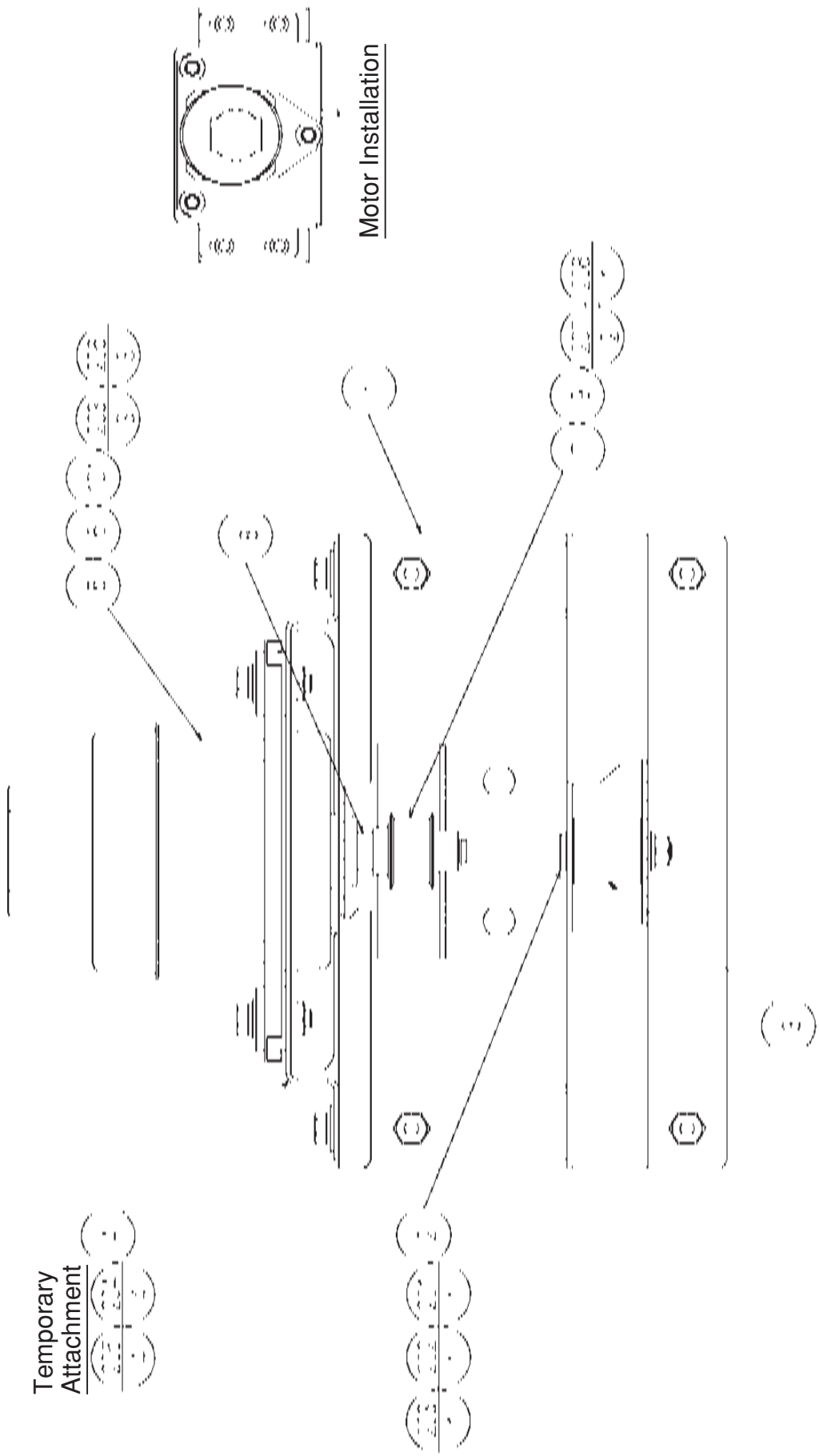

⑥ ASSY STEERING MOTOR (FZR-1240)

(D-2/2)

ITEM NO.	PART NO.	DESCRIPTION	NOTE
1	FZR-1241	STEERING MOTOR BASE	
2	FZR-1242	STOPPER SHAFT	
3	FZR-1243	STOPPER RUBBER	
4	FZR-1244	STEERING MOTOR BRKT	
5	ASK-3502	MOTOR SPACER	
6	ASK-3503	MOTOR COLLAR	
7	SPG-2453	KEY 4 × 4 × 40	
8	SPG-2454	MOTOR SHAFT COLLAR	
9	SPG-2504	PULLEY 20 S5M	
101	350-5448-01	SERVO MOTOR 500W NEW	
201	050-H00800	HEX NUT M8	
202	060-S00800	SPR WSHR M8	
203	060-F00800	FLT WSHR M8	
204	030-000820-S	HEX BLT W/S M8 × 20	
205	068-852216	FLT WSHR 8.5-22 × 1.6	
206	030-000830-S	HEX BLT W/S M8 × 30	
207	028-A00408-P	SET SCR HEX SKT CUP P M4 × 8	
208	065-S012S0-Z	STP RING BLK OZ S12	

⑦ ASSY COCKPIT (FZR-2000)

(D-1/2)

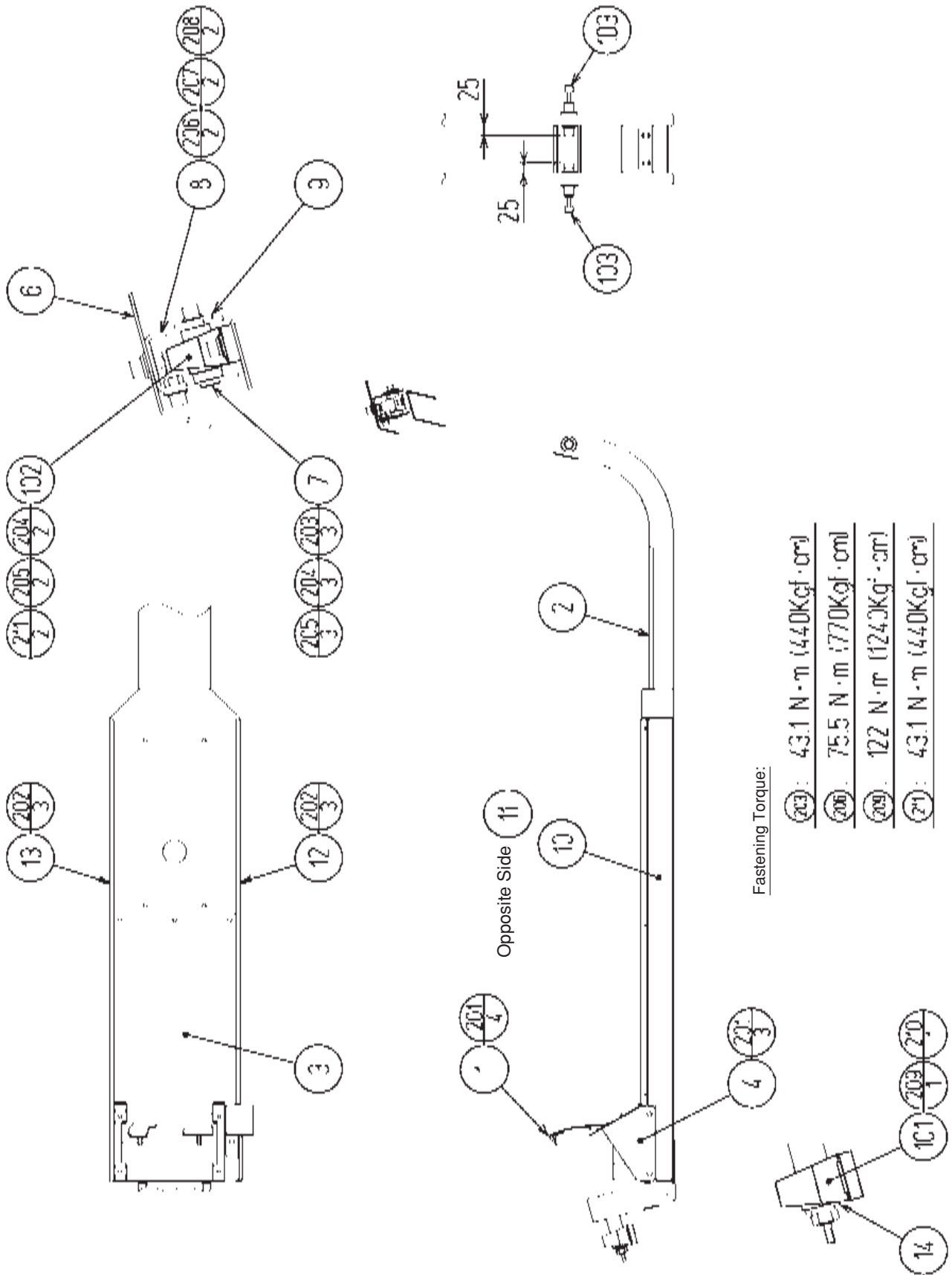

⑦ ASSY COCKPIT (FZR-2000)

(D-2/2)

ITEM NO.	PART NO.	DESCRIPTION	NOTE
1	SPG-2200	ASSY ACCEL&BRAKE	
2	FZR-2001	COCKPIT FRAME	
3	FZR-2002	FLOOR MAT COCKPIT	
4	FZR-2003	FOOTREST	
6	FZR-2005	REAR SHAFT BRKT	
7	FZR-2006	REAR SHAFT	
8	FZR-2007	REAR SHAFT HOUSING	
9	FZR-2008	WASHER	
10	FZR-2011	STICKER COCKPIT SIDE L	
11	FZR-2012	STICKER COCKPIT SIDE R	
12	FZR-2013	SIDE SASH L	
13	FZR-2014	SIDE SASH R	
14	TTR-3205	FLT 14.5-36 × 3.2	
101	100-5240	BEARING FAI30 (NTN UCPE206D)	
102	100-5435	BEARING 25 (NTN UCPE205)	
103	601-11144	SHOCK ABSORBER SSF	
104	310-5027-1503	INSL SUT TUBE ID 15	
105	280-5009-01	CORD CLAMP 21	
201	FAS-300001	HEX BLT CRM W/FS M8 × 20	
202	000-T00408-0C	M SCR TH CRM M4 × 8	
203	020-001020-0Z	HEX SKT CAP SCR BLK 0Z M10 × 20	
204	060-S01000	SPR WSHR M10	
205	060-F01000	FLT WSHR M10	
206	FAS-200050	HEX SKT CAP SCR BLK 0Z M12 × 30	
207	060-S01200	SPR WSHR M12	
208	060-F01200	FLT WSHR M12	
209	050-H01400	HEX NUT M14	
210	060-S01400	SPR WSHR M14	
211	FAS-200051	HEX SKT CAP SCR BLK 0Z M10 × 30	
212	000-P00408	M SCR PH M4 × 8	
213	060-S00400	SPR WSHR M4	
214	060-F00400	FLT WSHR M4	
301	FZR-60047	WH COCKPIT01	
302	600-6972-1000	WIRE HARN EARTH ID5 1000MM	

⑧ ASSY ACCEL&BRAKE (SPG-2200)

(D-1/2)

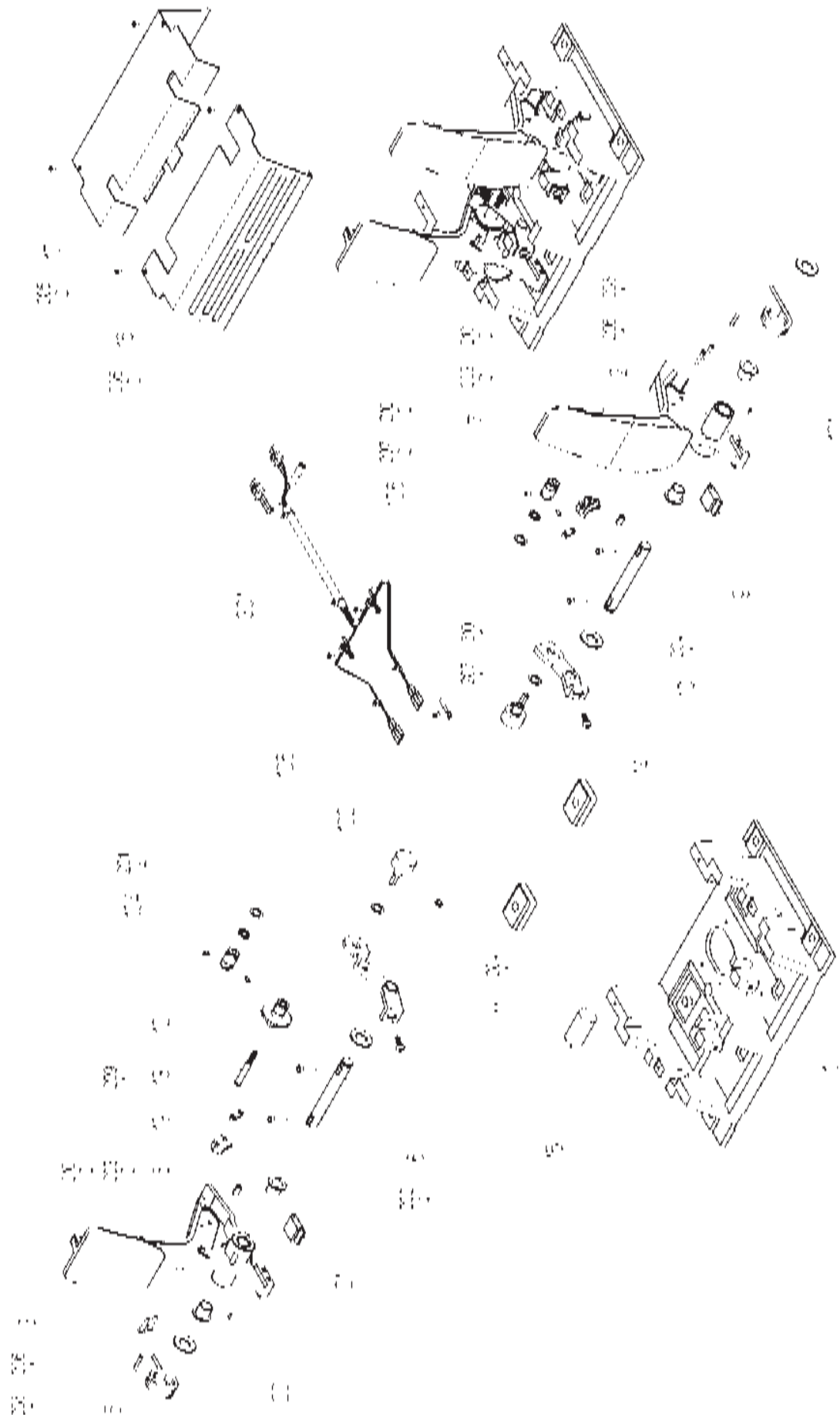

⑧ ASSY ACCEL&BRAKE (SPG-2200)

(D-2/2)

ITEM NO.	PART NO.	DESCRIPTION	NOTE
1	SPG-2201	BASE	
2	SPG-2202	ACCEL PEDAL	
3	SPG-2203	BRAKE PEDAL	
4	SPG-2204	ACCEL SPRING	
5	SPG-2205	BRAKE SPRING	
6	SPG-2206	SHAFT	
7	SPG-2207	ACCEL GEAR	
8	SPG-2208	BRAKE GEAR	
9	SPG-2209	NEUTRAL STOPPER	
10	SPG-2210	VR PLATE ACCEL	
11	SPG-2211	VR PLATE BRAKE	
12	SPG-2212	AMPL GEAR	
13	SPG-2213	GEAR SHAFT	
14	SPG-2214	STOPPER	
15	SPG-2215	RUBBER CUSHION	
16	SPG-2216	COVER	
17	SPG-2217	VR COVER	
19	SPG-2219	GEAR STAY	
20	SPG-2220	WSHR	
21	SPG-2221	NEUTRAL STOPPER D	
101	100-5263	BEARING 12(OILES 80F-1212)	
102	220-5484	VOL CONT B-5K OHM	
	220-5753	VOL CONT B-5K OHM	
104	601-7944	GEAR 15	
105	310-5029-F15	SUMITUBE F F15MM	
106	280-0419	HARNES LUG	
201	028-A00304-P	SET SCR HEX SKT CUP P M3 × 4	
202	020-000520-OZ	HEX SKT H CAP SCR BLK M5 × 20	
203	000-P00420	M SCR PH M4 × 20	
204	000-P00508-W	M SCR PH W/FS M5 × 8	
205	000-T00408-0C	M SCR TH CRM M4 × 8	
206	FAS-450005	SPR PIN BLK OZ 6 × 10	
207	000-P00405	M SCR PH M4 × 5	
208	FAS-000001	M SCR TH CRM M3 × 6	
209	050-H00500	HEX NUT M5	
210	060-F00400	FLT WSHR M4	
301	600-6840	WIRE HARN ACCEL&BRAKE	

⑨ ASSY SEAT (FZR-2100)

(D-1/2)

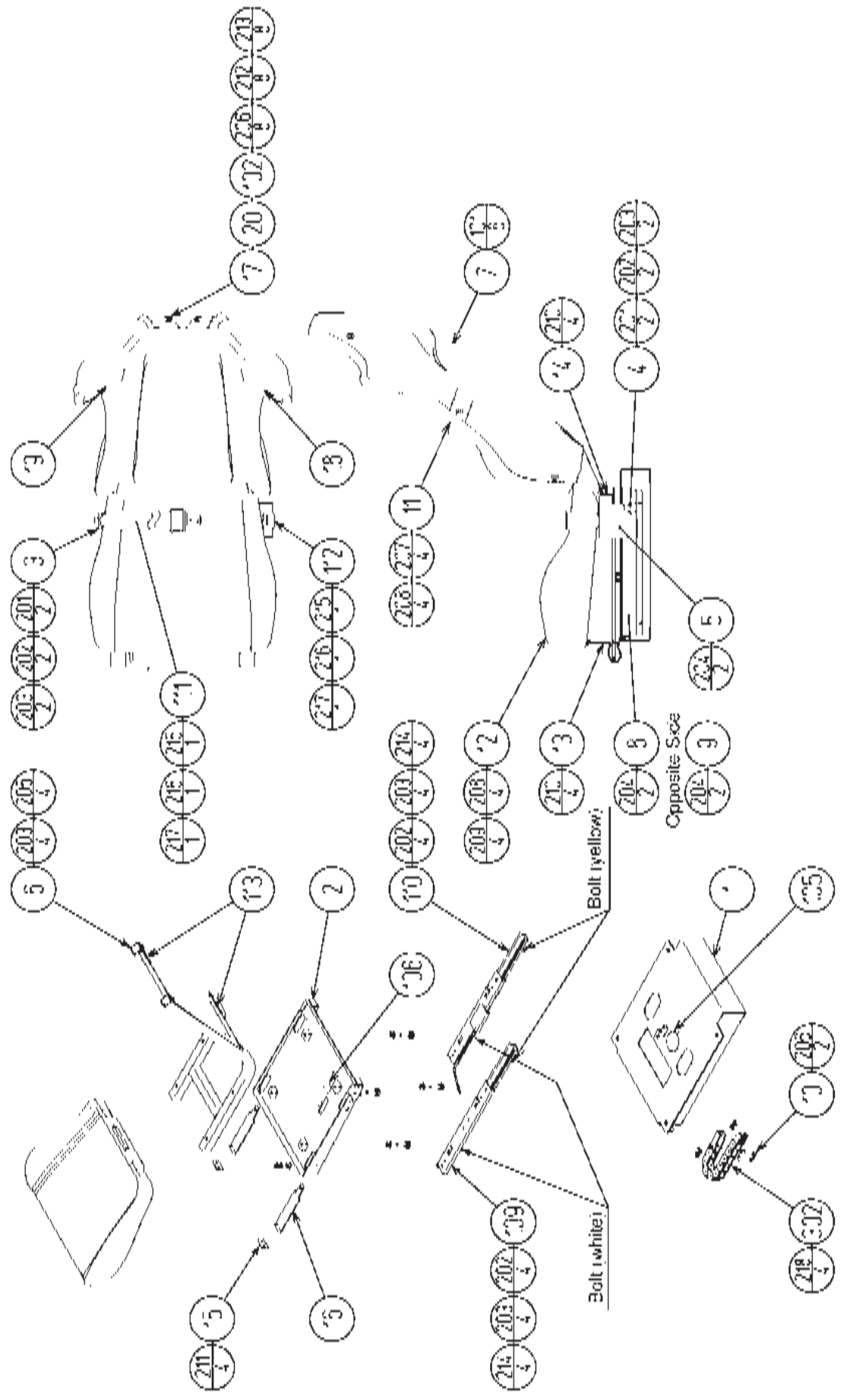

Fastening Torque:

⑳: 2.5 N·m (22JKg·cm)

㉑: 4.31 N·m (44JKg·cm)

⑨ ASSY SEAT (FZR-2100)

(D-2/2)

ITEM NO.	PART NO.	DESCRIPTION	NOTE
1	FZR-2101	SEAT BASE	
2	FZR-2102	SEAT SLANT TRAY	
3	FZR-2103	SEAT BELT BASE	
4	FZR-2104	SEAT BELT CATCH BASE	
5	FZR-2105	SEAT BELT CATCH COVER	
6	FZR-2106	SEAT FRAME	
7	FZR-2107	SEAT REAR COVER	
8	FZR-2108	SEAT BASE SIDE COVER L	
9	FZR-2109	SEAT BASE SIDE COVER R	
10	SPG-2409	CABLE BEAR BRKT	
11	DUT-2202	UPPER SEAT	
12	DUT-2203	LOWER SEAT	
13	DUT-2206	SAFETY GUARD F	
14	FZR-2110	SAFETY GUARD R	
15	SPG-2411	RUBBER PLATE	
16	SPG-2410	PROTECT RUBBER	
17	STC-1607	SP MOUNT BRKT	
18	STC-1608	SPEAKER NET L	
19	STC-1609	SPEAKER NET R	
20	INY-1302-B	MASK CUSHION SIDE	
101	280-5297	SCRIVET 8 1K31	
102	130-5162-01	GULL BOX SPEAKER 16OHM 8W	
103	280-5009-01	CORD CLAMP 2I	
104	280-5275-SR10	CORD CLAMP SR10	
105	601-6563-188	BUSH 24T	
106	601-6563-100	BUSH 24T	
107	209-0023	CONN CLOSED END	
108	601-0460	PLASTIC TIE BELT 100 MM	
109	601-11309	SEAT RAIL LONG L	
110	601-11310	SEAT RAIL LONG R	
111	601-11330	SEAT BELT	
112	601-11162-01	SEAT BELT CATCH W/TUBE	
113	601-6231-D050	EDGING NEW TYPE	
201	FAS-290001	HEX SKT SCR BH BLK M8 × 20	
202	060-S00800-0B	SPR WSHR BLK M8	
203	060-F00800-0B	FLT WSHR BLK M8	
204	000-T00408-0C	M SCR TH CRM M4 × 8	
205	030-000820-S	HEX BLT W/S M8 × 20	
206	000-P00410-W	M SCR PH W/FS M4 × 10	
207	030-000855-S	HEX BLT W/S M8 × 55	
208	068-852216	FLT WSHR 8.5-22 × 1.6	
209	030-000850-S	HEX BLT W/S M8 × 50	
210	000-T00408-0B	M SCR TH BLK M4 × 8	
211	000-T00516-0B	M SCR TH BLK M5 × 16	
212	012-P00412	TAP SCR #2 PH 4 × 12	
213	060-F00400	FLT WSHR M4	
214	050-H00800	HEX NUT M8	
215	FAS-290036	HEX SKT SCR BH BLK M10 × 20	
216	060-S01000-0B	SPR WSHR BLK M10	
217	060-F01000-0B	FLT WSHR BLK M10	
218	000-T00616-0B	M SCR TH BLK M6 × 16	
219	000-P00408	M SCR PH M4 × 8	
220	060-S00400	SPR WSHR M4	
301	600-6774-016	WIRE HARN SPEAKER EXT	
302	600-6774-017	WIRE HARN SEAT EXT	
303	FZR-60060	WH SEAT BELT	

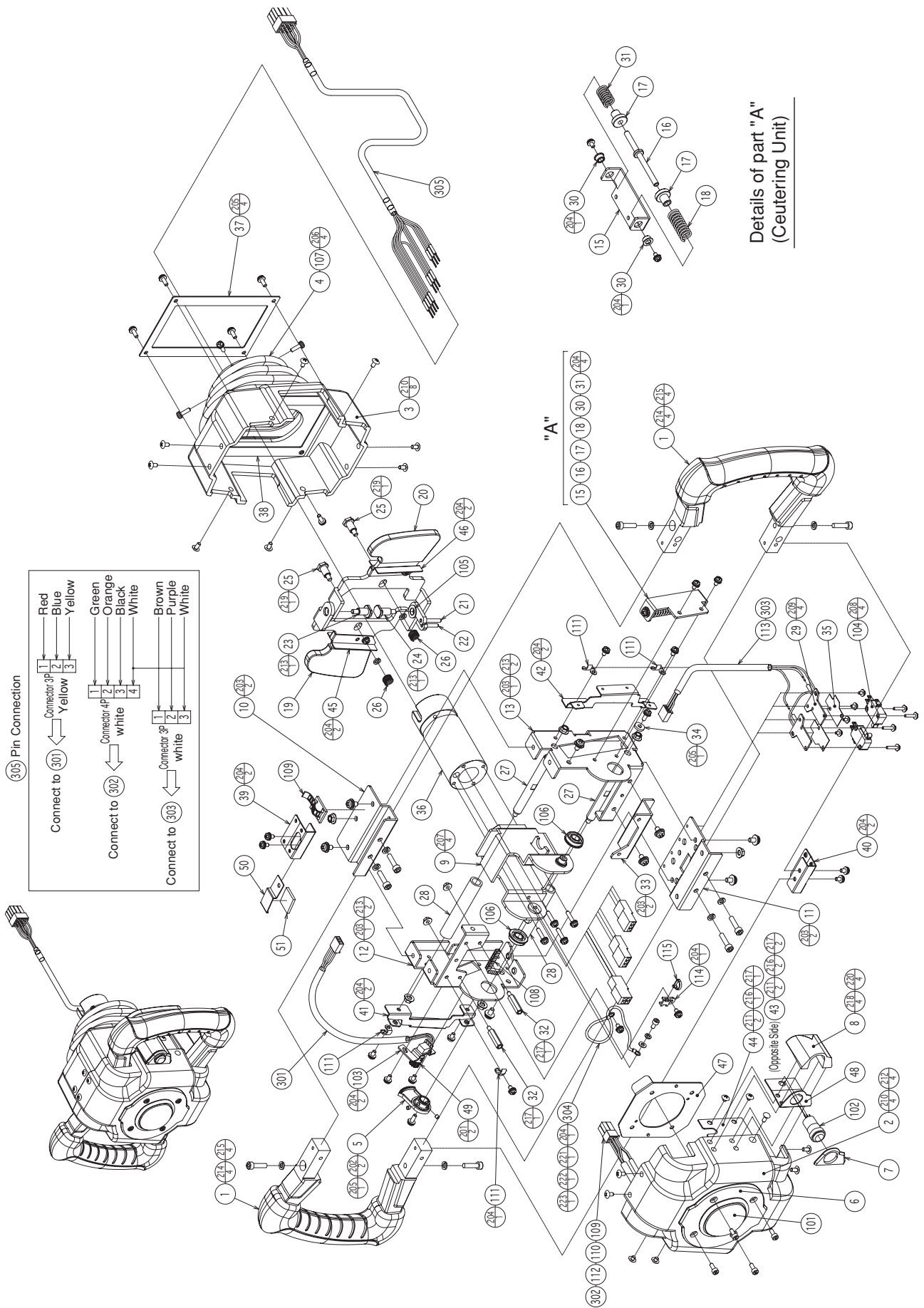

⑩ ASSY STEERING (FZR-2500)

(D-2/3)

ITEM NO.	PART NO.	DESCRIPTION	NOTE
1	FZR-2501	HANDLE	
2	FZR-2502	STEERING COVER FRONT	
3	FZR-2503	STEERING COVER REAR	
4	FZR-2504	STEERING BELLOWS	
5	FZR-2505	GEAR 77	
6	FZR-2506	BOOST PANEL	
7	FZR-2507	SUB BOOST PANEL	
8	FZR-2508	SUB BOOST HOLDER	
9	FZR-2509	STEERING SHAFT BASE	
10	FZR-2510	STEERING BASE A	
11	FZR-2511	STEERING BASE B	
12	FZR-2512	STEERING STAND L	
13	FZR-2513	STEERING STAND R	
15	FZR-2515	CENTERING BASE	
16	FZR-2516	CENTERING SHAFT	
17	FZR-2517	CENTERING COLLAR	
18	FZR-2518	CENTERING SPRING A	
19	FZR-2519	PADDLE L	
20	FZR-2520	PADDLE R	
21	FZR-2521	PIN L	
22	FZR-2522	PIN R	
23	FZR-2523	PADDLE SHAFT A	
24	FZR-2524	PADDLE SHAFT B	
25	FZR-2525	PADDLE STOPPER PIN	
26	FZR-2526	PADDLE SPRING	
27	FZR-2527	STOPPER SHAFT	
28	FZR-2528	STOPPER RUBBER	
29	FZR-2529	SW ADJUST PLATE	
30	FZR-2530	BUSH	
31	FZR-2531	CENTERING SPRING B	
32	FZR-2532	HEX SPACER	
33	FZR-2533	BOOST BUTTON BASE B	
34	FZR-2534	BEARING COLLAR	
35	FZR-2535	INSULATION SHEET	
36	FZR-2536	HANDLE COLLAR	
37	FZR-2537	BELLOWS PLATE A	
38	FZR-2538	BELLOWS PLATE B	
39	FZR-2539	COVER STAY A	
40	FZR-2540	COVER STAY B	
41	FZR-2541	COVER STAY L	
42	FZR-2542	COVER STAY R	
43	FZR-2543	PADDLE COVER L	
44	FZR-2544	PADDLE COVER R	
45	FZR-2545	SLIDE PLATE L	
46	FZR-2546	SLIDE PLATE R	
47	FZR-2547	BOOST BUTTON PLATE	
48	FZR-2548	SUB BOOST STAY	
49	350-5580	GEAR 10.5	
50	FZR-2549	CORD CLAMP STAY	
51	FZR-2550	SPONGE SHEET	

⑩ ASSY STEERING (FZR-2500)

(D-2/3)

ITEM NO.	PART NO.	DESCRIPTION	NOTE
101	509-6035	SW OBSA-60UMQ-B-1TLED-B-12V	
102	509-5524-01	PUSH BUTTON SW BLUE	
103	220-5775	VOL CONT B-10K OHM W/BD	
104	509-6036	SW MICRO MATSUSHITA AM51615A7	
105	100-5365-0803	OILES BEARING 80F 0803	
106	100-5102	BEARING 9 NSK F699ZZ	
107	280-6622-40080	SPACER TUBE	
108	601-6563-48	BUSH 2.4T	
109	280-5008	CORD CLAMP 15	
110	280-5275-SR10	CORD CLAMP SR10	
111	280-0419	HARNESS LUG	
112	310-5029-D15	SUMITUBE F D 15MM	
113	310-5029-G20	SUMITUBE F G 20MM	
114	280-5257	TIE BASE TA1S8	
115	601-0460	PLASTIC TIE BELT 100 MM	
201	028-A00304-P	SET SCR HEX SKT CUP P M3 × 4	
202	028-A00404-P	SET SCR HEX SKT CUP P M4 × 4	
203	000-P00510-W	M SCR PH W/FS M5 × 10	
204	000-P00408-W	M SCR PH W/FS M4 × 8	
205	000-P00412-WB	M SCR PH W/FS BLK M4 × 12	
206	FAS-000125	M SCR PH W/SMALL FS BLK M4 × 14	
207	000-P00420-W	M SCR PH W/FS M4 × 20	
208	000-P00316-W	M SCR PH W/FS M3 × 16	
209	000-P00306-W	M SCR PH W/FS M3 × 6	
210	000-T00406-0B	M SCR TH BLK M4 × 6	
211	FAS-000124	M SCR TH BLK M4 × 4	
212	FAS-200053	HEX SKT H CAP SCR CRM M4 × 10	
213	050-F00500	FLG NUT M5	
214	020-000520-OZ	HEX SKT H CAP SCR BLK M5 × 20	
215	060-S00500-0B	SPR WSHR BLK M5	
216	031-000410-0B	CRG BLT BLK M4 × 10	
217	050-F00400	FLG NUT M4	
218	060-S00400-0B	SPR WSHR BLK M4	
219	FAS-600019	SPR WSHR BLK D=8.5 M5	
220	020-000412-OZ	HEX SKT H CAP SCR BLK OZ M4 × 12	
221	020-000408-OZ	HEX SKT CAP SCR BLK OZ M4 × 8	
222	060-S00400	SPR WSHR M4	
223	060-F00400	FLT WSHR M4	
301	FZR-60057X	WH HANDLE01	
302	FZR-60058X	WH HANDLE02	
303	FZR-60059	WH HANDLE03	
304	600-6972-0150	WIRE HARN EARTH ID5 0150MM	
305	FZR-60046	WH MONITOR BOX08	

⑪ ASSY PILLAR BASE (FZR-3000)

(D-1/2)

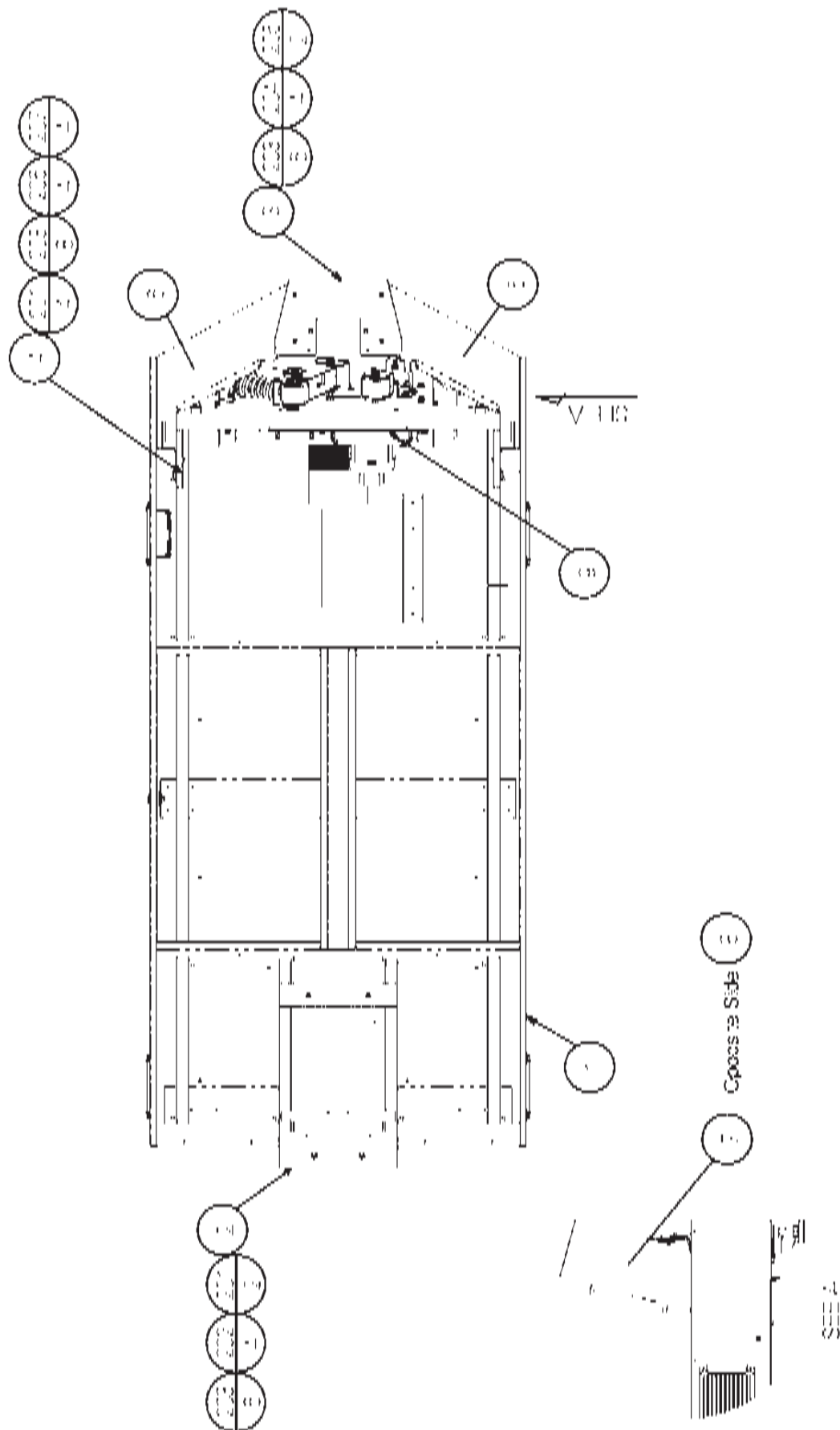

⑪ ASSY PILLAR BASE (FZR-3000)

(D-2/2)

ITEM NO.	PART NO.	DESCRIPTION	NOTE
1	FZR-3100	ASSY SUBCABI BASE	
2	FZR-3001	FRONT PILLAR	
3	FZR-3002	REAR PILLAR	
4	FZR-3003	REAR PILLAR SUPPORT	
5	FZR-3004X	STICKER REAR PILLAR L	
6	FZR-3005X	STICKER REAR PILLAR R	
7	FZR-3006	STICKER PILLAR LOWER L	
8	FZR-3007	STICKER PILLAR LOWER R	
9	FZR-3008	CUSHION SPONGE PILLAR	
101	280-5009-01	CORD CLAMP 21	
201	030-000820-S	HEX BLT W/S M8 × 20	
202	030-000850-S	HEX BLT W/S M8 × 50	
203	068-852216	FLT WSHR 8.5-22 × 1.6	
204	030-000870-S	HEX BLT W/S M8 × 70	
205	030-0008A0-S	HEX BLT W/S M8 × 100	
206	050-H00800	HEX NUT M8	
207	060-S00800	SPR WSHR M8	
301	FZR-60050	WH BILLBOARD01	

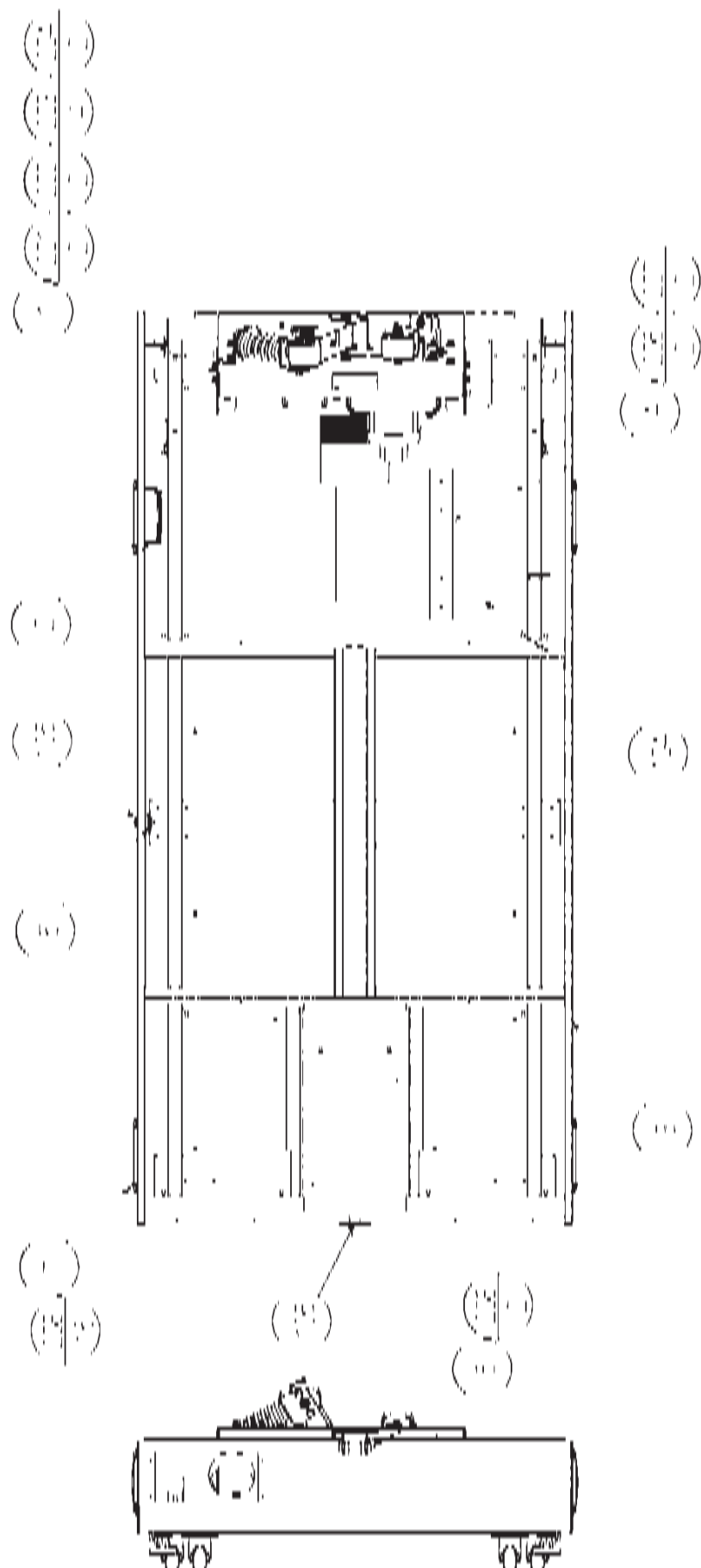

⑫ ASSY SUBCABI BASE (FZR-3100)

(D-2/2)

ITEM NO.	PART NO.	DESCRIPTION	NOTE
1	FZR-3200	ASSY ROLLING MECHA	
2	STR-1070	FAN UNIT	
3	FZR-3101	BASE	
4	FZR-3102	WOOFER BAND	
5	FZR-3103	LOCKING TONGUE	
6	FZR-3104	CABLE COVER	
7	253-5460-01	AIR VENT BLACK	
101	280-5009-01	CORD CLAMP 21	
102	209-0023	CONN CLOSED END	
103	601-0460	PLASTIC TIE BELT 100 MM	
104	130-5097	SPEAKER BOX SUPER WOOFER	
105	220-5575	CAM LOCK MASTER W/O KEY	
106	280-6658	EDGE HOLDER EH-14U	
201	050-H00800	HEX NUT M8	
202	060-S00800	SPR WSHR M8	
203	068-852216	FLT WSHR 8.5-22 × 1.6	
204	030-000820-S	HEX BLT W/S M8 × 20	
206	000-P00408-W	M SCR PH W/FS M4 × 8	
207	011-T03512	TAP SCR TH 3.5 × 12	
208	000-T00408-0B	M SCR TH BLK M4 × 8	
301	FZR-60036	WH BASE14	
302	FZR-60052	WH WOOFER	
304	600-7269-0200	ASSY LAN CABLE 0200CM	
305	FZR-6001	ASSY WIRE BASE DC	
306	FZR-6002	ASSY WIRE BASE AC	
309	FZR-60079	WH BASE23	

⑬ BASE (FZR-3101)

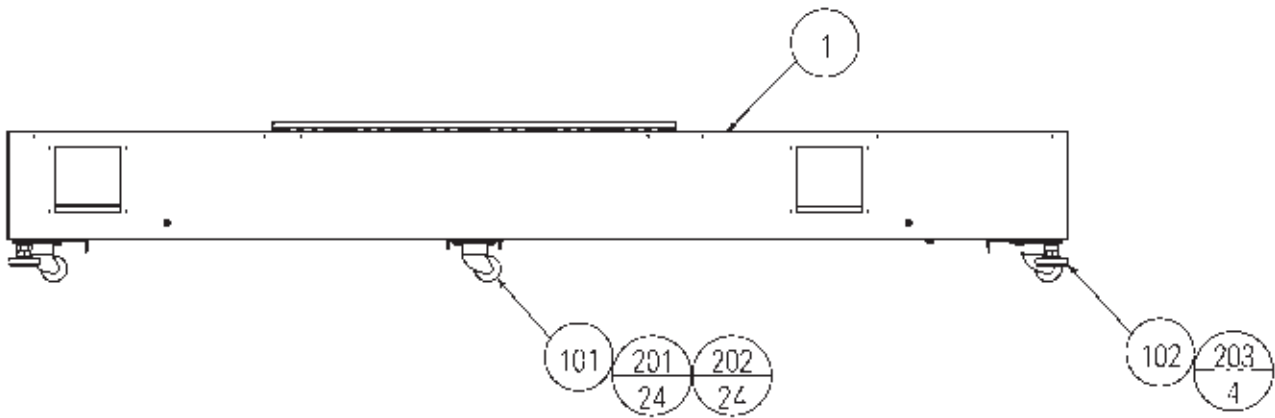

ITEM NO.	PART NO.	DESCRIPTION	NOTE
1	FZR-3101-A	BASE BLANK	
101	601-11312	CASTER 50(TAKIGEN K-300HJ-50)	
102	601-5882	LEG ADJUSTER (TAKIGEN C-280-2)	
201	030-000616-S	HEX BLT W/S M6 × 16	
202	068-652016	FLT WSHR 6.5-20 × 1.6	
203	050-H01600-0B	HEX NUT BLK M16	

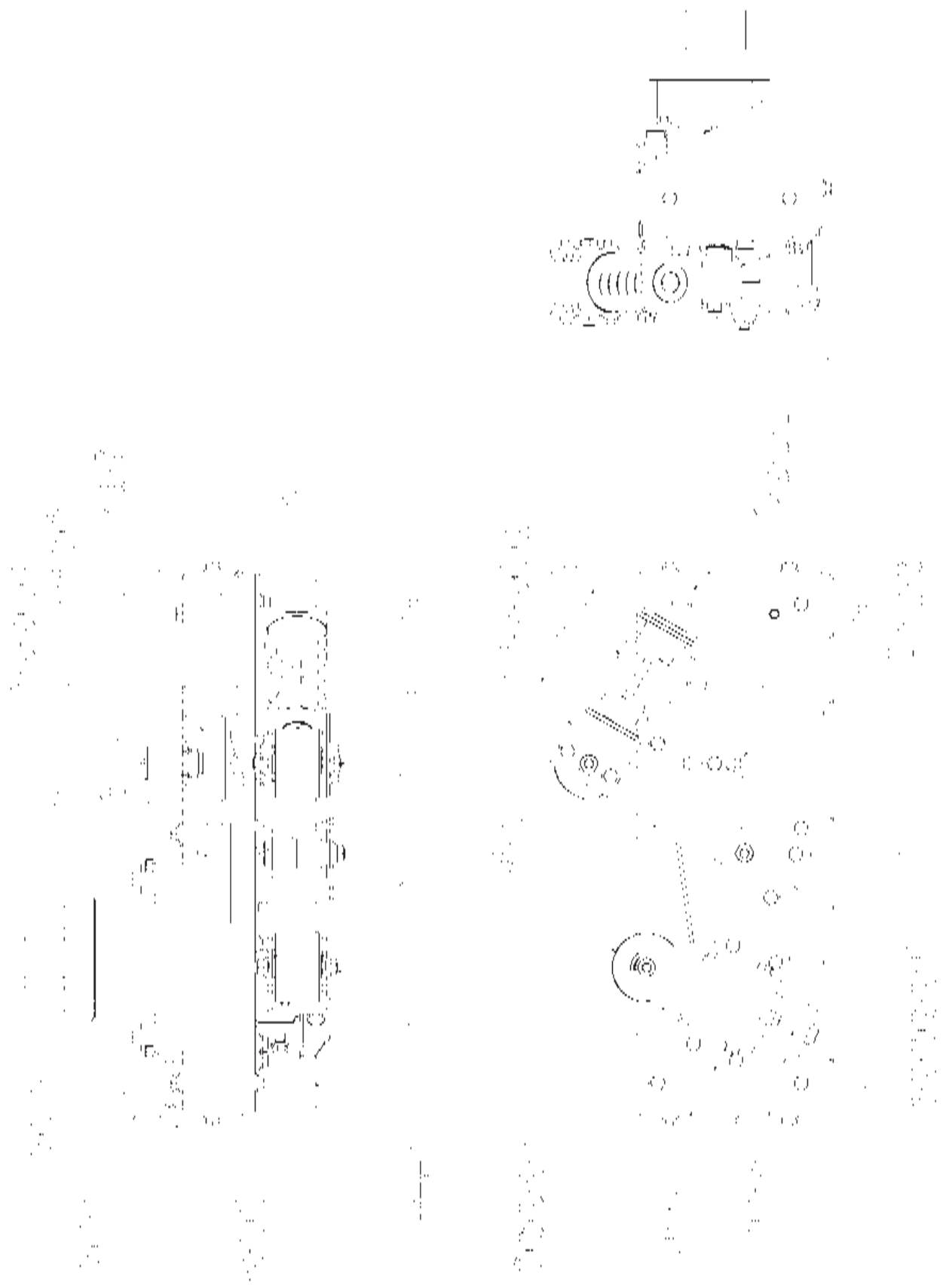

14 ASSY ROLLING MECHA (FZR-3200)

(D-2/2)

ITEM NO.	PART NO.	DESCRIPTION	NOTE
1	FZR-3250	ASSY ROLLING MOTOR	
2	FZR-3201	ROLL MOTOR BASE A	
3	FZR-3202	ROLL MOTOR BASE B	
4	FZR-3203	DRIVE PULLEY S8M 22	
5	FZR-3204X	DRIVE SHAFT	
6	FZR-3205	DRIVE SHAFT COLLAR	
7	FZR-3206	TENSIONER SHAFT	
8	FZR-3207	TENSIONER ARM	
9	FZR-3208	TENSIONER ARM SUPPORT	
10	FZR-3209	ARM SPRING HOLDER	
11	FZR-3210	SPRING HOLDER	
12	FZR-3211	IDLER	
13	FZR-3212	SPRING IDLER SHAFT	
14	FZR-3213	ADJUST IDLER BRKT	
15	FZR-3214	ADJUST IDLER SHAFT	
16	FZR-3215	ADJUST IDLER STAY	
17	FZR-3216	ADJUST IDLER HOLDER	
18	FZR-3217	MOTOR BASE BRKT L	
19	FZR-3218	MOTOR BASE BRKT R	
20	FZR-1003	IDLER COLLAR	
21	SPG-2505	PULLEY 60 S5M	
22	ASK-3606	KEY 5 × 5-10.5	
23	DYN-1270	STOPPER KEY	
24	SPA-2011	KEY 5 × 49	
25	TX-2017	COMP SPRING	
26	440-WS0047-EG	STICKER W FINGER GEAR ENG	
27	FZR-3219	DRIVE SHAFT COLLAR BRAKE	
28	SLC-0006	FLAT WASHER 8.4-25 × 2	
101	100-5112	BEARING 17 (NSK 6003ZZ)	
102	100-5070	BEARING 15 (NSK 6002ZZ)	
103	601-11328	TIMING BELT 150 HP S5M 600	
104	601-11311	BRAKE BXH-08-10 24V	
105	209-0023	CONN CLOSED END	
106	601-0460	PLASTIC TIE BELT 100 MM	
107	211-5409	AMP S. SPRESSOR CONN 172006-1	
108	211-5410	CONTACT 170284-1	
109	481-5510	DIODE DSA12T(SANYO)	
	481-5511	DIODE 1S1887A(TOSHIBA)	
201	030-000820-S	HEX BLT W/S M8 × 20	
202	068-852216	FLT WSHR 8.5-22 × 1.6	
203	FAS-200048	HEX SKT CAP SCR BOZ S=80 M8 × 80	
204	050-H00800	HEX NUT M8	
205	060-F00800	FLT WSHR M8	
206	028-C00412-P	SET SCR CH CUP P M4 × 12	
207	030-000612-S	HEX BLT W/S M6 × 12	
208	FAS-500046	HEX NUT TYPE3 M10	
209	060-S01000	SPR WSHR M10	
210	060-F01000	FLT WSHR M10	
211	030-000812-S	HEX BLT W/S M8 × 12	
212	030-001020-S	HEX BLT W/S M10 × 20	
213	065-S032H0-Z	STP RING BLK OZ H32	
214	065-S020S0-Z	STP RING BLK OZ S20	
215	020-000850-OZ	HEX SKT H CAP SCR BLK OZ M8 × 50	
216	068-652016	FLT WSHR 6.5-20 × 1.6	
217	020-000530-OZ	HEX SKT H CAP SCR BLK OZ M5 × 30	
218	060-S00500	SPR WSHR M5	
219	028-C00512-P	SET SCR CH CUP P M5 × 12	
301	FZR-60053	WH CLUTCH	

⑮ ASSY ROLLING MOTOR (FZR-3250)

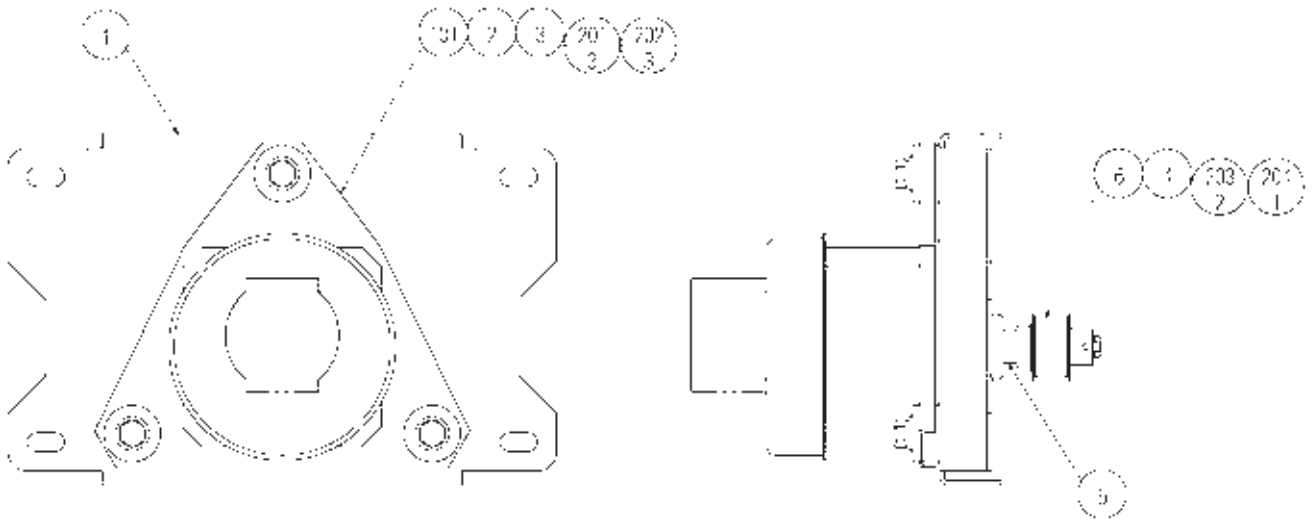

ITEM NO.	PART NO.	DESCRIPTION	NOTE
1	FZR-3251	ROLLING MOTOR BRKT	
2	ASK-3502	MOTOR SPACER	
3	ASK-3503	MOTOR COLLAR	
4	SPG-2453	KEY 4 × 4 × 40	
5	SPG-2454	MOTOR SHAFT COLLAR	
6	SPG-2504	PULLEY 20 S5M	
101	350-5448-01	SERVO MOTOR 500W NEW	
201	030-000830-S	HEX BLT W/S M8 × 30	
202	060-F00800	FLT WSHR M8	
203	028-A00408-P	SET SCR HEX SKT CUP P M4 × 8	
204	065-S012S0-Z	STP RING BLK OZ S12	

①⑥ FAN UNIT (STR-1070)

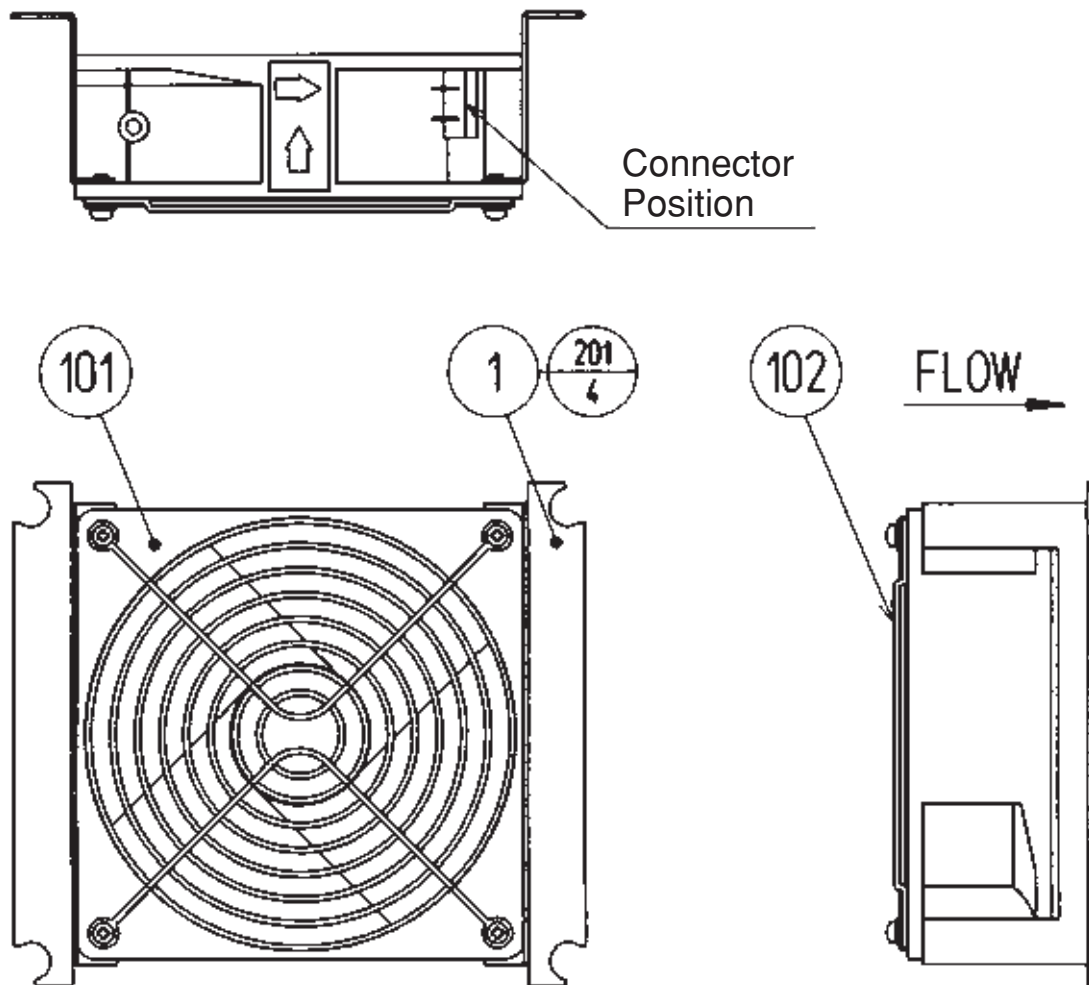

ITEM NO.	PART NO.	DESCRIPTION	NOTE
1	105-5340-01	FAN BRKT LONG	
101	260-0011-02	AXIAL FLOW FAN AC100V 50-60HZ	
102	601-8543	FAN GUARD	
201	000-P00312-W	M SCR PH W/FS M3 × 12	

①⑦ ASSY WIRE BASE DC (FZR-6001)

This is comprised of the following wire harnesses. ASSY drawing is not available.

ITEM NO.	PART NO.	DESCRIPTION	NOTE
101	601-0460	PLASTIC TIE BELT 100 MM	
303	FZR-60025	WH BASE03	
304	FZR-60026	WH BASE04	
305	FZR-60027	WH BASE05	
306	FZR-60028	WH BASE06	
307	FZR-60029	WH BASE07	
308	FZR-60030	WH BASE08	
309	FZR-60031	WH BASE09	
311	FZR-60033	WH BASE11	
312	FZR-60034	WH BASE12	
313	FZR-60035	WH BASE13	
315	FZR-60037	WH BASE15	
317	FZR-60062	WH BASE17	
319	FZR-60064	WH BASE19	
320	FZR-60068	WH BASE20	
325	600-7141-200	CABLE JVS TYPE A-B 200CM	
326	FZR-60073	WH BASE21	
327	FZR-60074	WH BASE22	
328	600-7009-2500	ASSY RGB CA D-SUB 15P 2500MM	

①⑧ ASSY WIRE BASE AC (FZR-6002)

This is comprised of the following wire harnesses. ASSY drawing is not available.

ITEM NO.	PART NO.	DESCRIPTION	NOTE
101	601-0460	PLASTIC TIE BELT 100 MM	
301	FZR-60023	WH BASE01	
302	FZR-60024	WH BASE02	
316	FZR-60038	WH BASE16	
318	FZR-60063	WH BASE18	

①⑨ ROLL VR UNIT (FZR-3050)

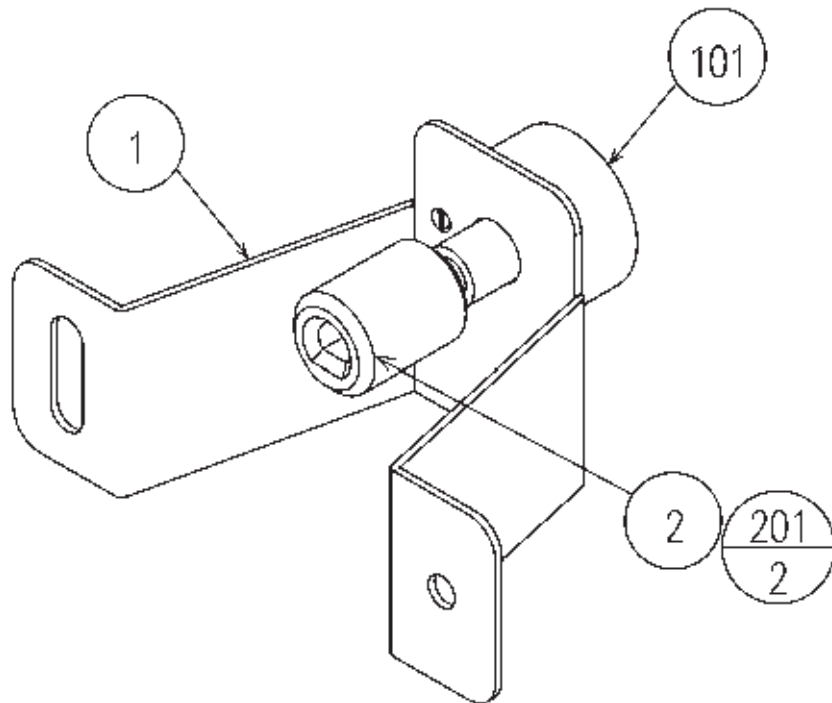

ITEM NO.	PART NO.	DESCRIPTION	NOTE
1	FZR-3051	ROLL VR BRKT	
2	601-7945	GEAR 20	
101	220-5484	VOL CONT B-5K OHM	
	220-5753	VOL CONT B-5K OHM (TOCOS)	
102	310-5029-F20	SUMITUBE F F 20MM	
201	028-A00306-P	SET SCR HEX SKT CUP P M3 × 6	
301	FZR-60054	WH ROLL VR	

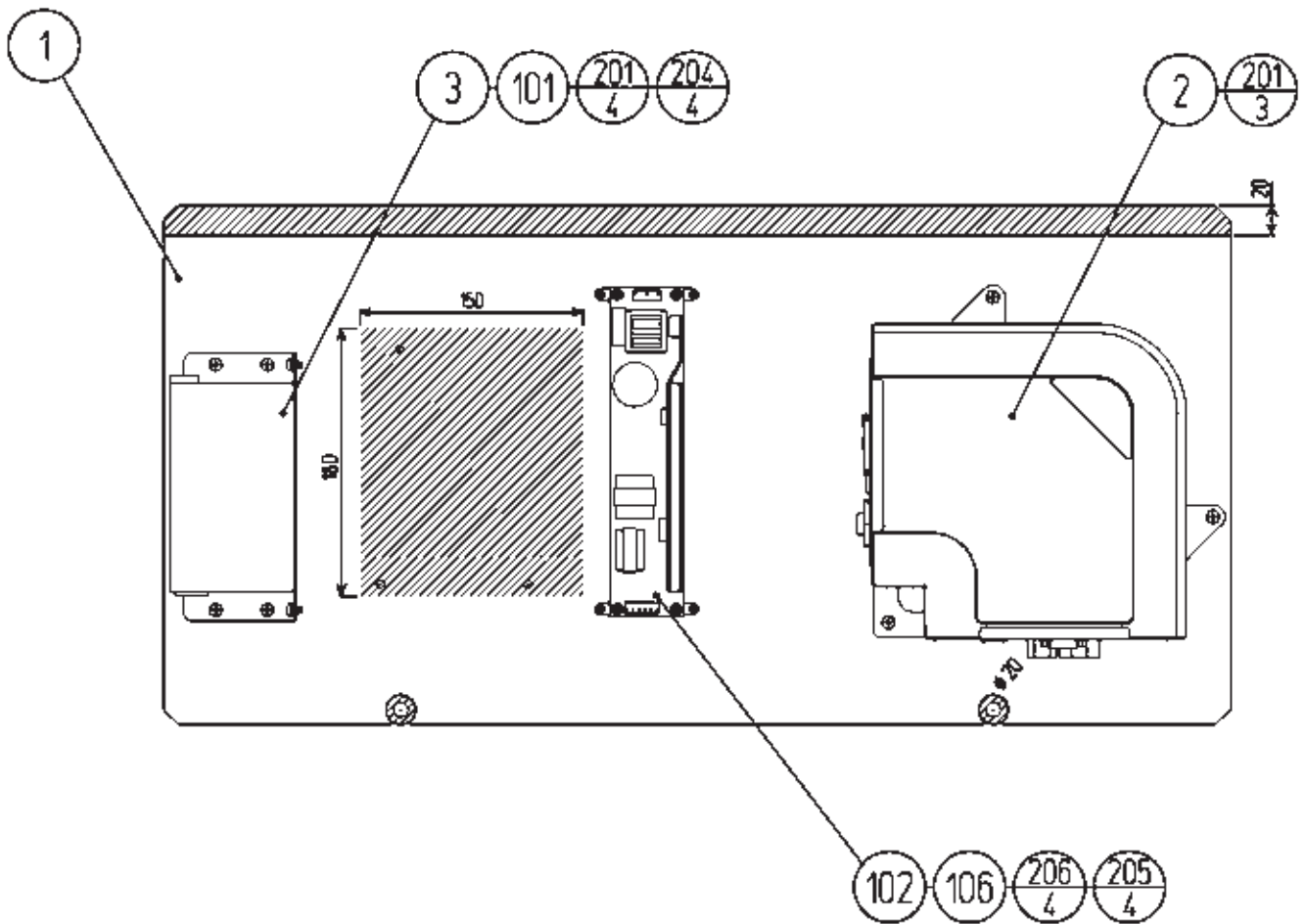

Do not wire across the diagonal lines.

②⑩ ASSY MAIN BD (FZR-4000)

(D-2/2)

ITEM NO.	PART NO.	DESCRIPTION	NOTE
1	FZR-4001	WOODEN BASE MAIN BD	
2	842-02DD511U	ASSY TRF FZR USA	<USA>
	842-02DD511E	ASSY TRF FZR EXP	<Others>
	842-04DD511E	ASSY TRF FZR ASIA	<Asia>
3	APC-4002	SW REGU BRKT	
101	400-5397-01	SW REGU FOR JVS VA	
102	400-5421-07512	SW REGU LCA75S-12	
104	280-5009-01	CORD CLAMP 21	
105	280-0419	HARNESS LUG	
106	601-7467	L-LOCK BK	
107	601-0460	PLASTIC TIE BELT 100 MM	
201	000-P00416-W	M SCR PH W/FS M4 × 16	
202	011-F00312	TAP SCR #1 FH 3 × 12	
203	011-T03512	TAP SCR TH 3.5 × 12	
204	000-P00406-W	M SCR PH W/FS M4 × 6	
205	011-T03516	TAP SCR TH 3.5 × 16	
206	000-P00308-W	M SCR PH W/FS M3 × 8	
302	FZR-60011X	WH MAIN BD01	
303	FZR-60012	WH MAIN BD02	
304	FZR-60013	WH MAIN BD03	
305	FZR-60014	WH MAIN BD04	
306	FZR-60069	WH MAIN BD05	

21 ASSY XFMR (FZR-4100)

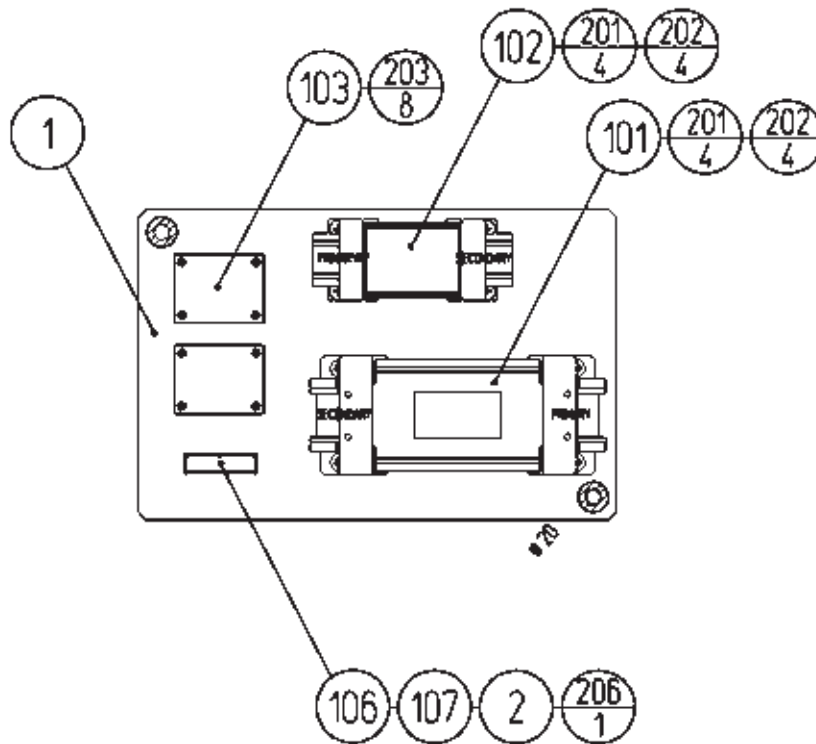

Do not wire across the diagonal lines.

ITEM NO.	PART NO.	DESCRIPTION	NOTE
1	FZR-4101	WOODEN BASE XFMR	
2	421-6595-08	STICKER 10A	
101	560-5510-V 560-5511-V	XFMR 100-120V 100V10A WB XFMR 220-240V 100V10A WB	<AC 100 - 120V Area> <AC 220 - 240V Area>
102	560-5394	XFMR 100V 14V10.5A WB	
103	839-1160	DC TERMINAL BD	
104	280-5009-01	CORD CLAMP 21	
105	280-0419	HARNESS LUG	
106	514-5028	FUSE HOLDER 1P W/COVER	
107	514-5036-10000	FUSE 6.4 × 30 10000MA 125V	
201	000-P00416-W	M SCR PH W/FS M4 × 16	
202	068-441616	FLT WSHR 4.4-16 × 1.6	
203	011-P00325	TAP SCR PH 3 × 25	
204	011-F00312	TAP SCR #1 FH 3 × 12	
205	011-T03512	TAP SCR TH 3.5 × 12	
206	011-P00316	TAP SCR #1 PH 3 × 16	
301	FZR-60001X	WH XFMR01	
302	FZR-60002	WH XFMR02	
303	FZR-60003	WH XFMR03	
304	FZR-60004	WH XFMR04	
305	FZR-60005	WH XFMR05	

22 ASSY AUDIO AMP (FZR-4200)

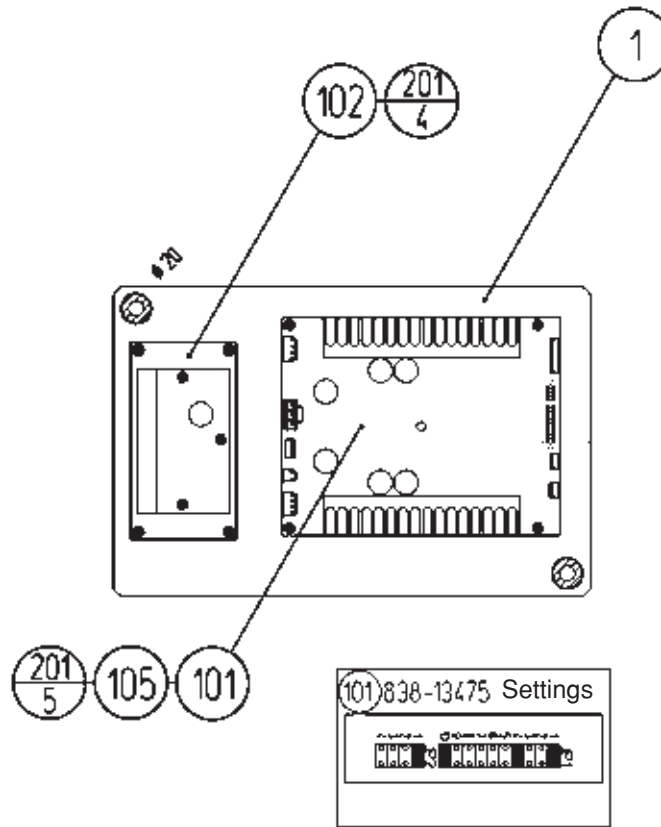

Do not wire across the diagonal lines.

ITEM NO.	PART NO.	DESCRIPTION	NOTE
1	FZR-4201	WOODEN BASE AMP	
101	838-13475	PWR AMP 4CH & MIXER	
102	838-11651-01	LOWPASS AMP W/LARGE HEAT SINK	
103	280-5009-01	CORD CLAMP 21	
104	280-0419	HARNESS LUG	
105	211-5305	C JMPR SCKT (IMSA-9206H-GF)	
201	011-P00325	TAP SCR PH 3 × 25	
202	011-F00312	TAP SCR #1 FH 3 × 12	
203	011-T03512	TAP SCR TH 3.5 × 12	
301	FZR-60006	WH AUDIO AMP01	
302	FZR-60007	WH AUDIO AMP02	
303	FZR-60008	WH AUDIO AMP03	
304	FZR-60009	WH AUDIO AMP04	
305	FZR-60010	WH AUDIO AMP05	
306	FZR-60070	WH AUDIO AMP06	

②③ ASSY I/O BD (FZR-4300)

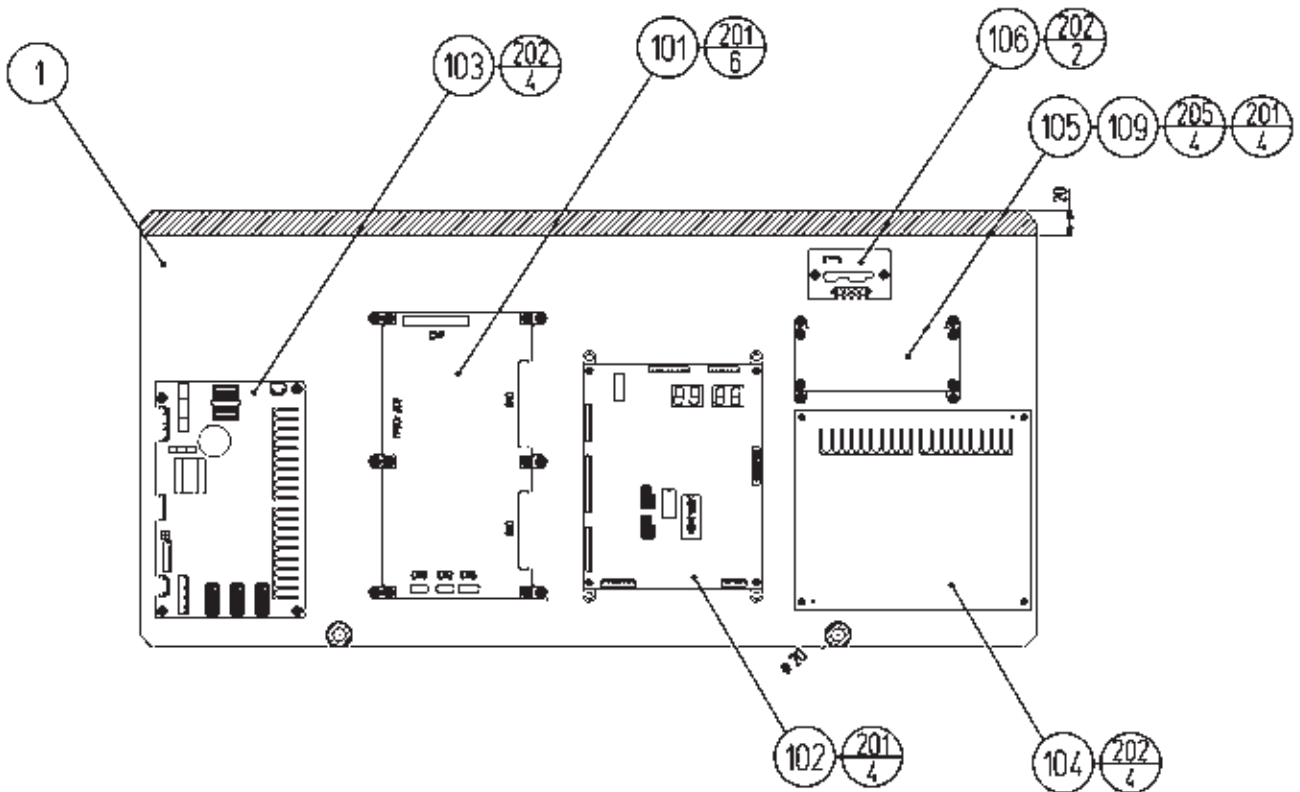

Do not wire across the diagonal lines.

ITEM NO.	PART NO.	DESCRIPTION	NOTE
1	FZR-4301	WOODEN BASE I/O	
101	837-13844-02	I/O CONTROL BD 2 W/O 232C DOG	
102	838-13843-01	DRIVE BD FZR	
103	838-14174	SERVO MOTOR DRIVE BD MIDI	
104	838-12912-01	SERVO MOTOR DRIVE BD NEW	
105	400-5421-03024	SW REGU LCA30S-24	
106	839-1148	4A DC SSR BD NH4P	
107	280-5009-01	CORD CLAMP 21	
108	280-0419	HARNESS LUG	
109	601-7467	L-LOCK BK	
201	011-T03516	TAP SCR TH 3.5 × 16	
202	011-P00325	TAP SCR PH 3 × 25	
203	011-F00312	TAP SCR #1 FH 3 × 12	
204	011-T03512	TAP SCR TH 3.5 × 12	
205	000-P00308-W	M SCR PH W/FS M3 × 8	
301	FZR-60015X	WH I/O BD01	
302	FZR-60016	WH I/O BD02	
304	FZR-60018	WH I/O BD04	

②④ ASSY HUB (FZR-4400)

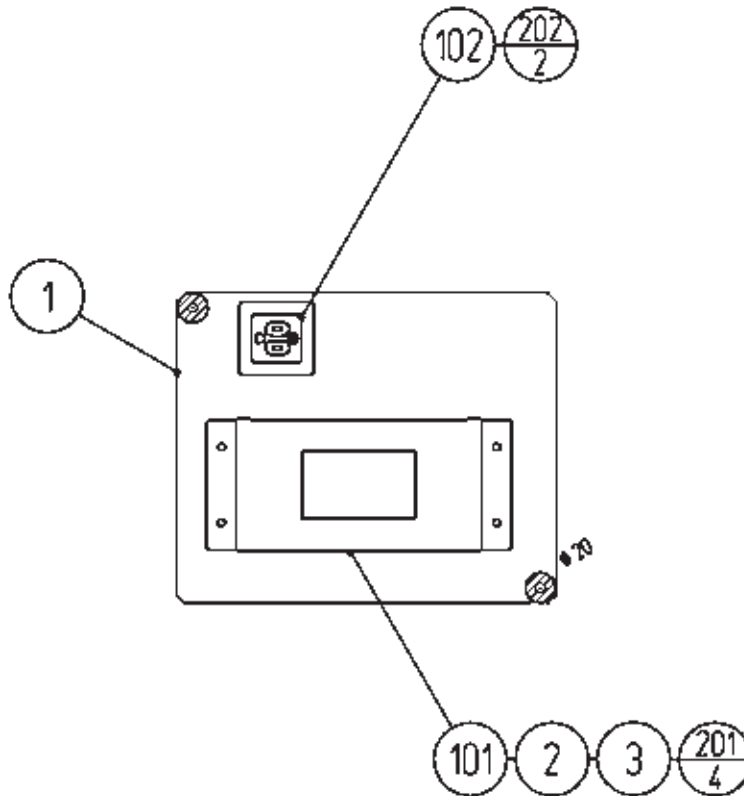

Do not wire across the diagonal lines.

ITEM NO.	PART NO.	DESCRIPTION	NOTE
1	FZR-4401	WOODEN BASE HUB	
2	FZR-4402	HUB HOLDER	
3	FZR-4403	CUSHION SPONGE	
101	601-11071-IS	SW HUB PCI FX-08IS	
102	601-8956-01	EARTH OUTLET WK3001W	
103	280-0419	HARNESS LUG	
104	280-5009-01	CORD CLAMP 21	
201	011-T03512	TAP SCR TH 3.5 × 12	
202	011-F03512	TAP SCR FH 3.5 × 12	
203	011-F00312	TAP SCR #1 FH 3 × 12	
301	FZR-60071	WH HUB01	

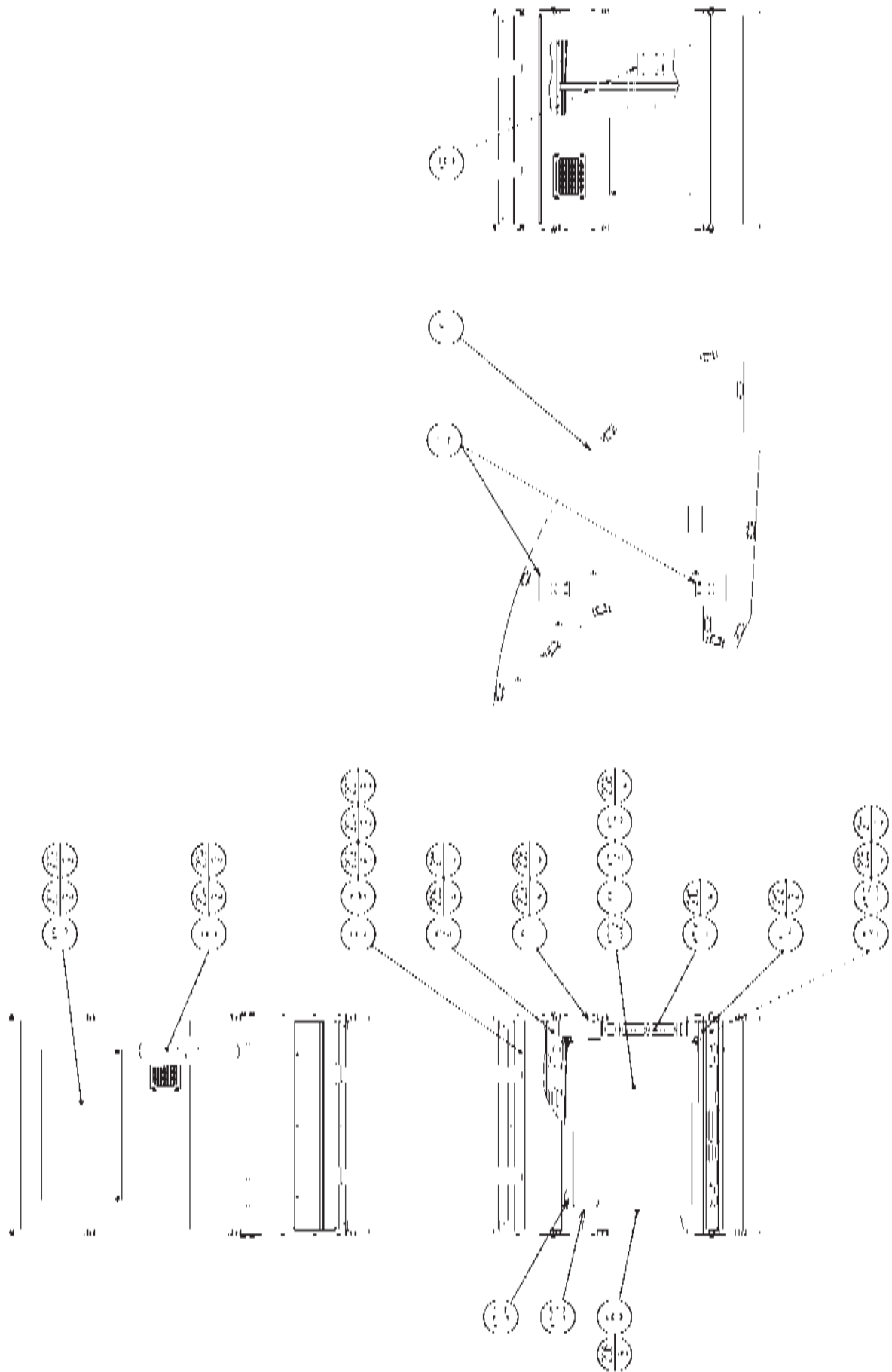

25 ASSY MONITOR BOX (FZR-1100)

(D-2/2)

ITEM NO.	PART NO.	DESCRIPTION	NOTE
1	FZR-1150X	ASSY SUB MONITOR BOX	
2	FZR-1105	MONITOR BEAM UPPER	
3	FZR-1106	MONITOR BEAM LOWER	
4	FZR-1107	MONITOR BEAM PLATE	
5	FZR-1108	MONITOR MASK	
6	FZR-1110	INST BASE	
7	FZR-1111	SPEAKER BRKT	
8	FZR-1112	MONITOR ADJUST PANEL	
9	FZR-1113-01	STICKER PLAY INSTRUCTION ENG	
10	FZR-1102	MONITOR BOX LID	
11	280-5112	BUSH FOR TV	
12	280-5113	COLLAR FOR TV	
13	280-5114	SPACER 6.4-25 × 2	
14	FZR-1114	MASK BLIND BRKT	
15	440-DS0013XEG	STICKER D MONITOR ENG	
101	130-5156-01	SPEAKER BOX 8OHM 20W VA1	
102	200-5955	ASSY CLR DSPL 29TYPE AUTO	
103	601-11329-0440	PACKING TAKIGEN FC779-3-4 0440	
104	601-11329-0560	PACKING TAKIGEN FC779-3-4 0560	
105	601-8412-50	EDGING	
201	000-T00425-0B	M SCR TH BLK M4 × 25	
202	068-441616-0B	FLT WSHR BLK 4.4-16 × 1.6	
203	068-552016	FLT WSHR 5.5-20 × 1.6	
204	000-P00416-WB	M SCR PH W/FS BLK M4 × 16	
205	030-000835-SB	HEX BLT BLK W/S M8 × 35	
206	000-P00530-W	M SCR PH W/FS M5 × 30	
207	000-P00430-S	M SCR PH W/S M4 × 30	
208	050-F00600	FLG NUT M6	
209	000-P00308-W	M SCR PH W/FS M3 × 8	
210	000-P00512-W	M SCR PH W/FS M5 × 12	
211	060-F00800	FLT WSHR M8	
212	050-F00400	FLG NUT M4	
301	FZR-60039	WH MONITOR BOX01	
310	FZR-6003	ASSY WIRE MONITOR BOX DC	
311	600-7194-911000	ASSY RGB CA D-SUB15P EXT1000MM	

26 ASSY SUB MONITOR BOX (FZR-1150X)

(D-1/2)

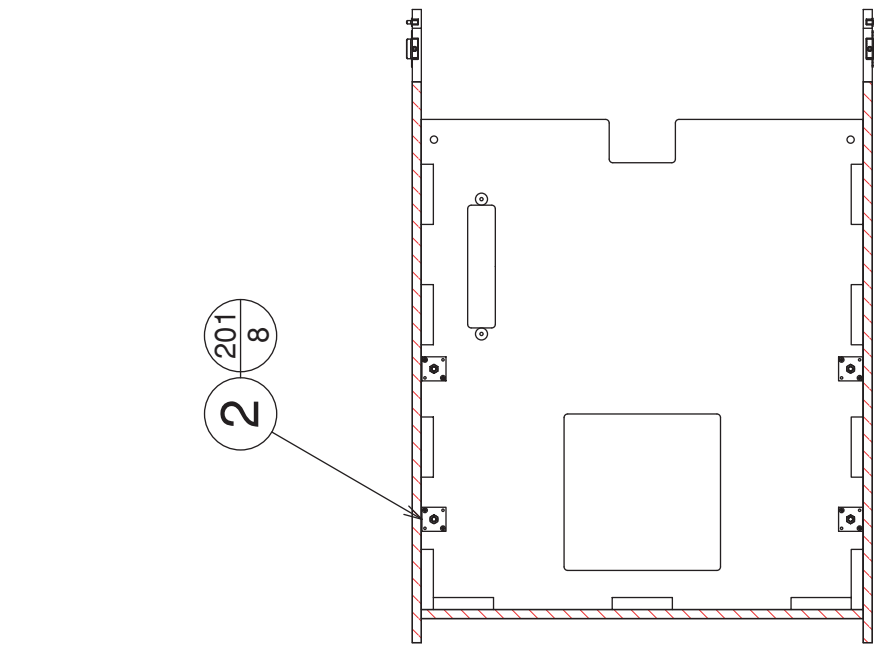

SECTION A

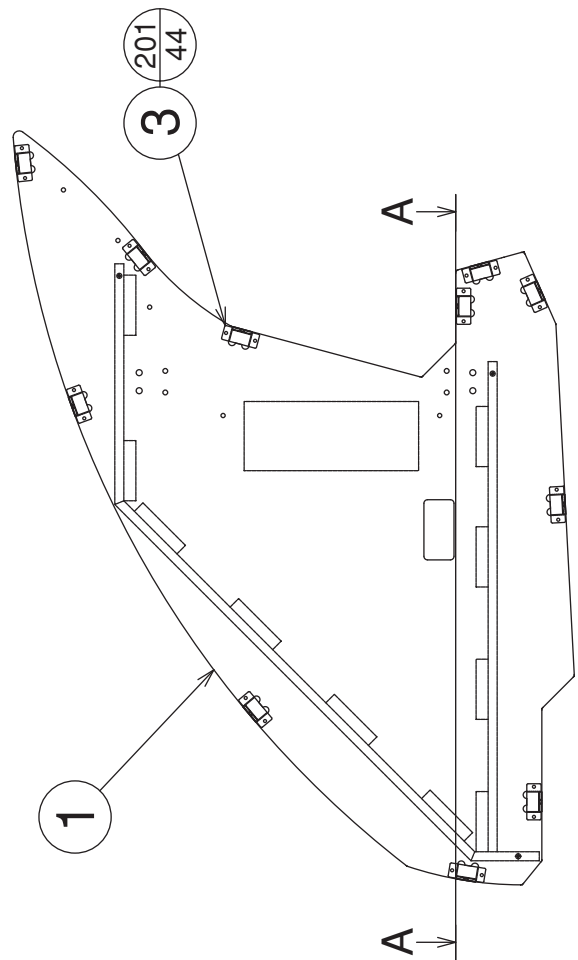
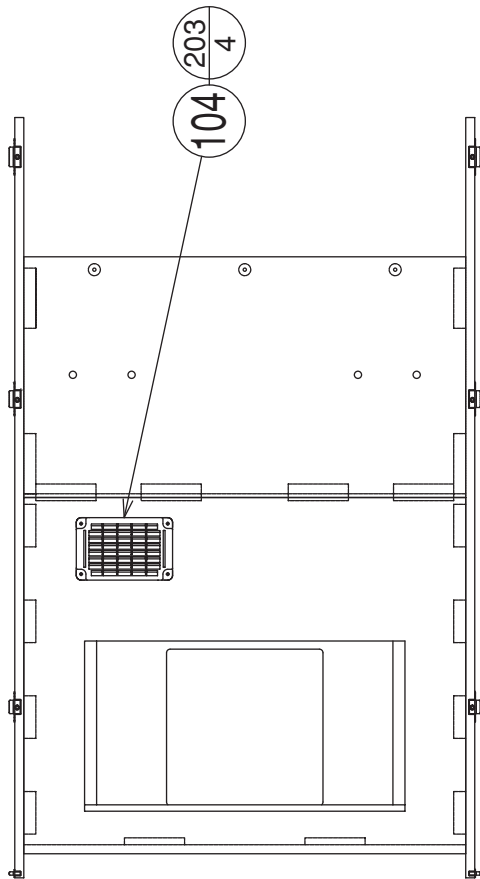

②6 ASSY SUB MONITOR BOX (FZR-1150X)

(D-2/2)

ITEM NO.	PART NO.	DESCRIPTION	NOTE
1	FZR-1151	MONITOR BOX	
2	DYN-2115	NUT PLATE M8	
3	FZR-1154	SIDE COVER BRKT	
101	280-5009-01	CORD CLAMP 21	
102	280-0419	HARNESS LUG	
104	253-5460-01	AIR VENT BLACK	
201	011-T03512	TAP SCR TH 3.5 × 12	
202	011-F00312	TAP SCR #1 FH 3 × 12	
203	000-T00425-0B	M SCR TH BLK M4 × 25	

②7 ASSY WIRE MONITOR BOX DC (FZR-6003)

This is comprised of the following wire harnesses. ASSY drawing is not available.

ITEM NO.	PART NO.	DESCRIPTION	NOTE
101	601-0460	PLASTIC TIE BELT 100 MM	
302	FZR-60040	WH MONITOR BOX02	
303	FZR-60041	WH MONITOR BOX03	
304	FZR-60042	WH MONITOR BOX04	
305	FZR-60043	WH MONITOR BOX05	
311	FZR-60075	WH MONITOR BOX09	
312	FZR-60076X	WH MONITOR BOX10	

28 ASSY SW PLATE L (FZR-1280)

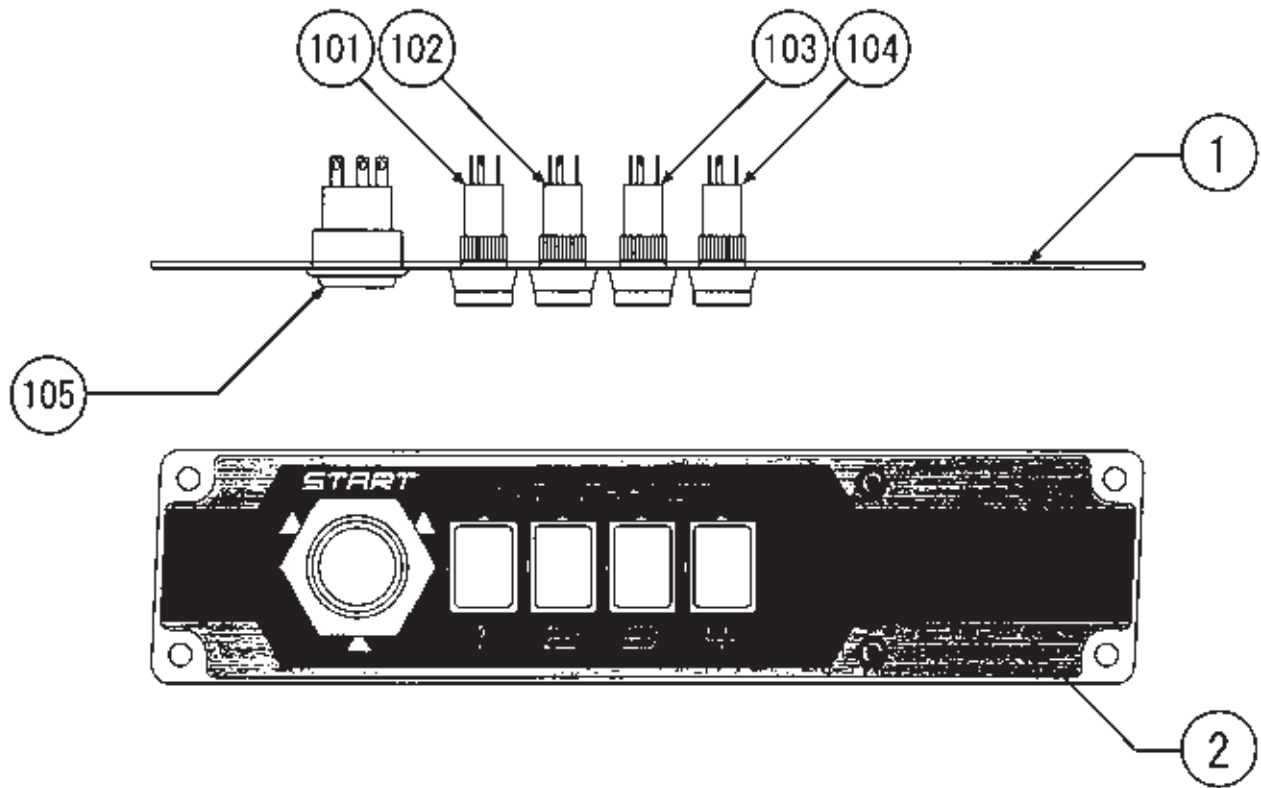

ITEM NO.	PART NO.	DESCRIPTION	NOTE
1	FZR-1281	SW PLATE L	
2	FZR-1282	STICKER SW PLATE L	
101	509-5779-RE	SW PB W/LAMP 6V RED	
102	509-5779-BL	SW PB W/LAMP 6V BLUE	
103	509-5779-YE	SW PB W/LAMP 6V YELLOW	
104	509-5779-GR	SW PB W/LAMP 6V GREEN	
105	509-0161	SW PB TYPE 1T YEL W/LAMP	
106	601-0460	PLASTIC TIE BELT 100 MM	
301	600-6817-042	WIRE HARN VR SW	

②9 ASSY SW PLATE R (FZR-1290)

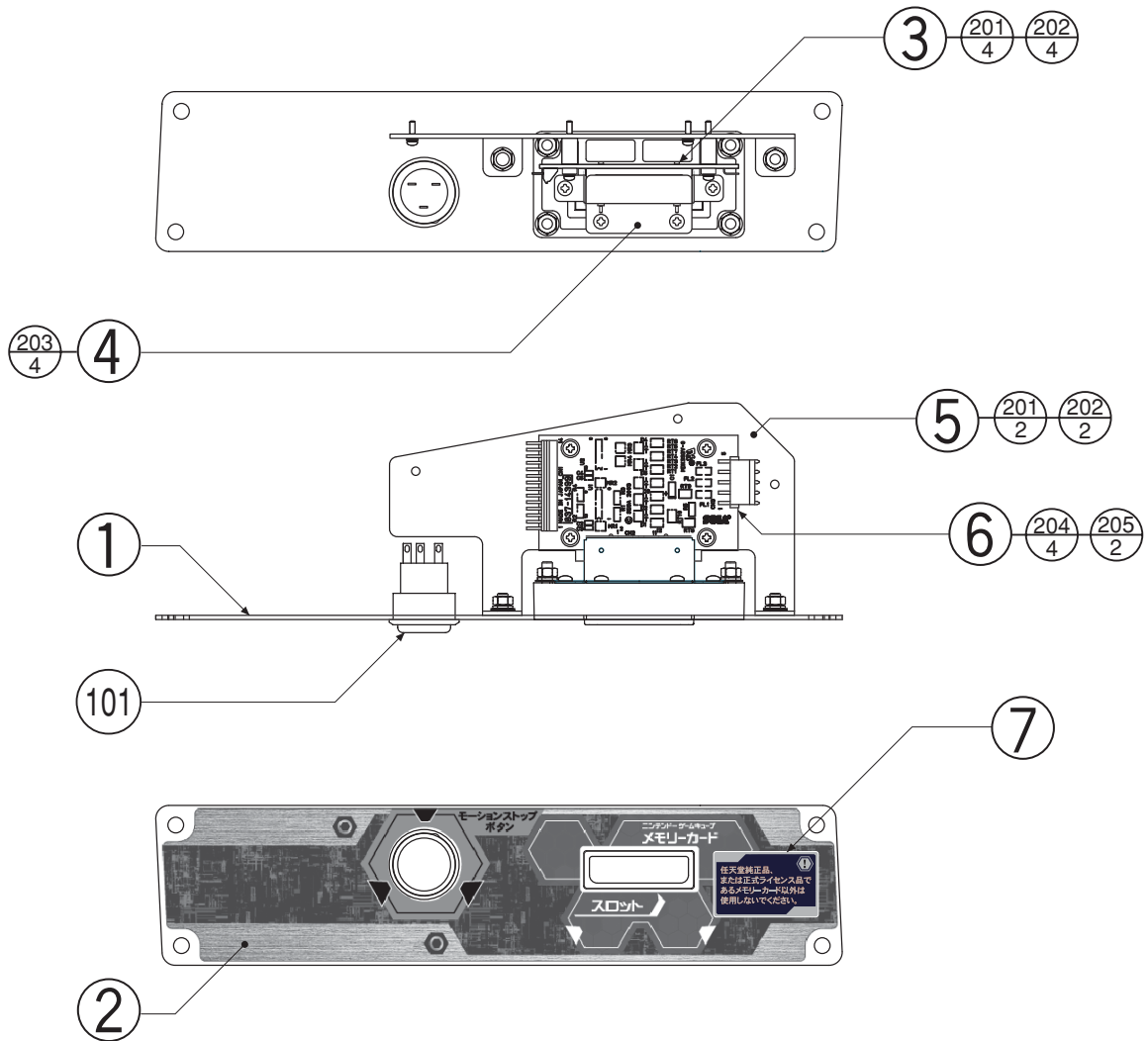

ITEM NO.	PART NO.	DESCRIPTION	NOTE
1	FZR-1291	SW PLATE R	
2	FZR-1292-01	STICKER SW PLATE R ENG	
3	FZR-1293	MEMORY SLOT BASE	
4	FZR-1294	MEMORY SLOT HOLD BRKT	
5	FZR-1295	MEMORY BD BASE DX	
6	837-14399	MEMORY CARD I/F MC BD	
7	FZR-1297-01	STICKER MEMORY CAUTION ENG	
101	509-5329	PUSH BUTTON SW 1T RED	
102	280-0419	HARNESS LUG	
201	050-U00400	U NUT M4	
202	060-F00400	FLT WSHR M4	
203	012-P00308	TAP SCR #2 PH 3 × 8	
204	000-P00320-W	M SCR PH W/FS M3 × 20	
205	FAS-000128	M SCR PH W/FS M2 × 18	
206	000-P00408-W	M SCR PH W/FS M4 × 8	
301	FZR-60061	WH MOTION STOP	
302	FZR-60077	WH MEM CARD01	
303	FZR-60078	WH MEM CARD02	

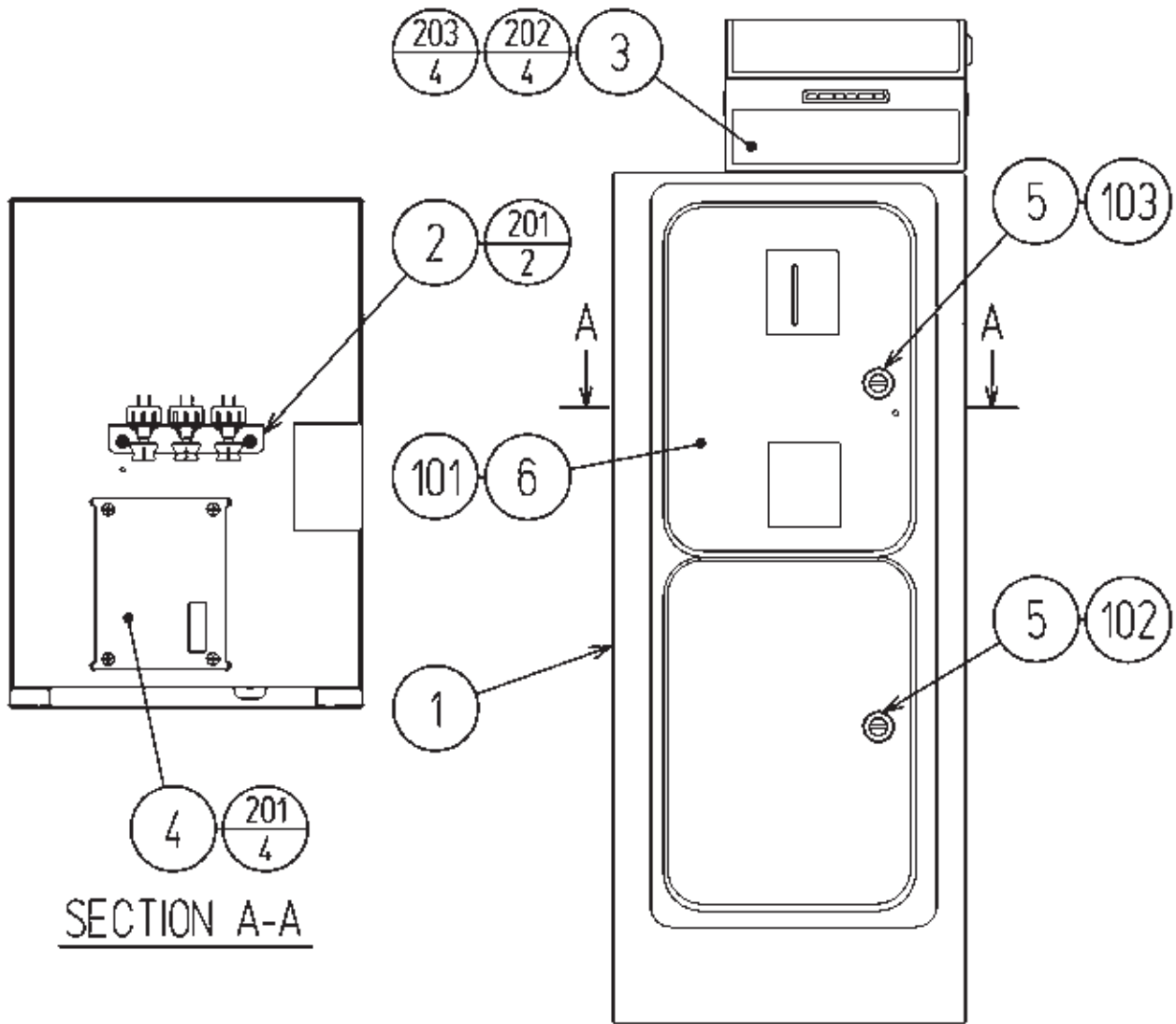

30 ASSY COINCHUTE TOWER (FZR-1400)

(D-2/2)

ITEM NO.	PART NO.	DESCRIPTION	NOTE
1	FZR-1401	COINCHUTE TOWER	
2	FZR-1450	SW UNIT	
3	VOF-0460	CARD UNIT TWIN R	
4	105-5171	CHUTE PLATE SINGLE	<Others>
	105-5172	CHUTE PLATE DOUBLE	<USA>
5	DP-1167	TNG LKG	<Others>
		Locally supplied	<USA>
6	421-7501-02	STICKER 6.3V 0.15A	<Others>
		Locally supplied	<USA>
101	220-5237-92-04	ASSY C.C 2DR TAIWAN NT\$10	<Taiwan>
	220-5237-92-05	ASSY C.C 2DR HONG KONG \$1	<Hong Kong>
	220-5237-92-06	ASSY C.C 2DR MALAYSIA 50CENT	<Malaysia>
	220-5237-92-37	ASSY C.C 2DR SINGAPORE \$1	<Singapore>
	220-5237-92-09	ASSY C.C 2DR KOREA 100W	<Korea>
	220-5237-92-08	ASSY C.C 2DR AUSTRALIA \$1	<Australia>
		Locally supplied	<USA>
102	220-5574	CAM LOCK W/KEYS	<Others>
		Locally supplied	<USA>
103	220-5575	CAM LOCK MASTER W/O KEY	<Others>
		Locally supplied	<USA>
104	310-5029-F20	SUMITUBE F F 20MM	<Others>
		Locally supplied	<USA>
105	280-5009-01	CORD CLAMP 21	
106	280-5275-SR10	CORD CLAMP SR10	
107	601-5525-027	BUSH 1.2T	
108	601-0460	PLASTIC TIE BELT 100 MM	
201	000-P00408-W	M SCR PH W/FS M4 × 8	
202	030-000820-SB	HEX BLT W/S BLK M8 × 20	
203	060-F00800-0B	FLT WSHR BLK M8	
301	FZR-60048	WH COINCHUTE01	
302	FZR-60049	WH COINCHUTE02	
303	FZR-60065	WH COINCHUTE03	
304	600-6455-02	WIRE HARN C.C DOOR SINGLE	<Others>
		Locally supplied	<USA>
305	600-6972-0150	WIRE HARN EARTH ID5 0150MM	

③① SW UNIT (FZR-1450)

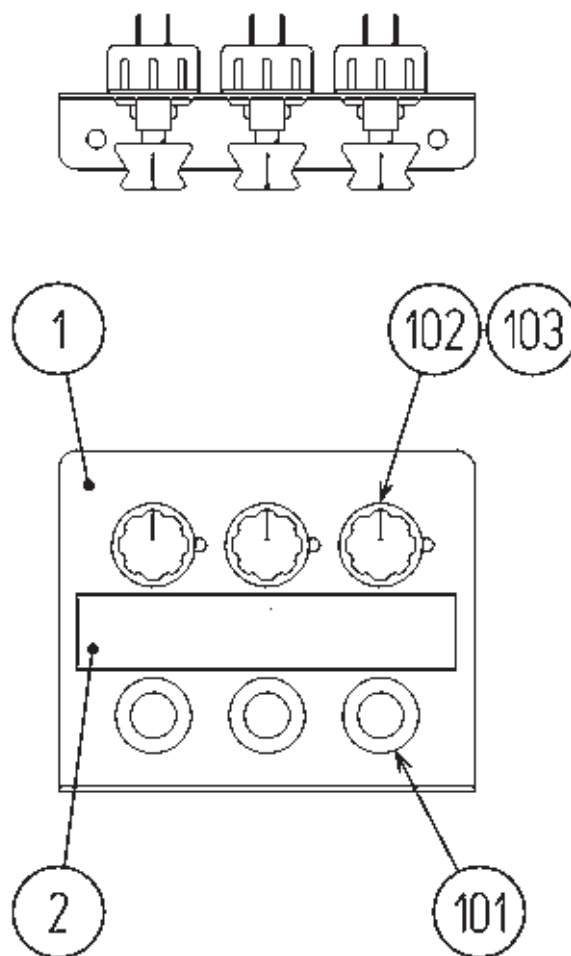

ITEM NO.	PART NO.	DESCRIPTION	NOTE
1	FZR-1451	SW BRKT	
2	421-11650-91	STICKER SW UNIT FZR	
101	509-5028	SW PB 1M	
102	220-5754	VOL CONT B5KOHM	
103	601-0042	KNOB 22 MM	
104	601-0460	PLASTIC TIE BELT 100 MM	
105	310-5029-F20	SUMITUBE F F 20MM	
301	600-6373-53	WIRE HARN TEST&SERVICE LEFT	
302	600-7076-055	WIRE HARN VOL LEFT YE	
303	600-7076-065	WIRE HARN VOL RIGHT BL	
304	600-6873-064	WIRE HARN S.VOLUME 1P	

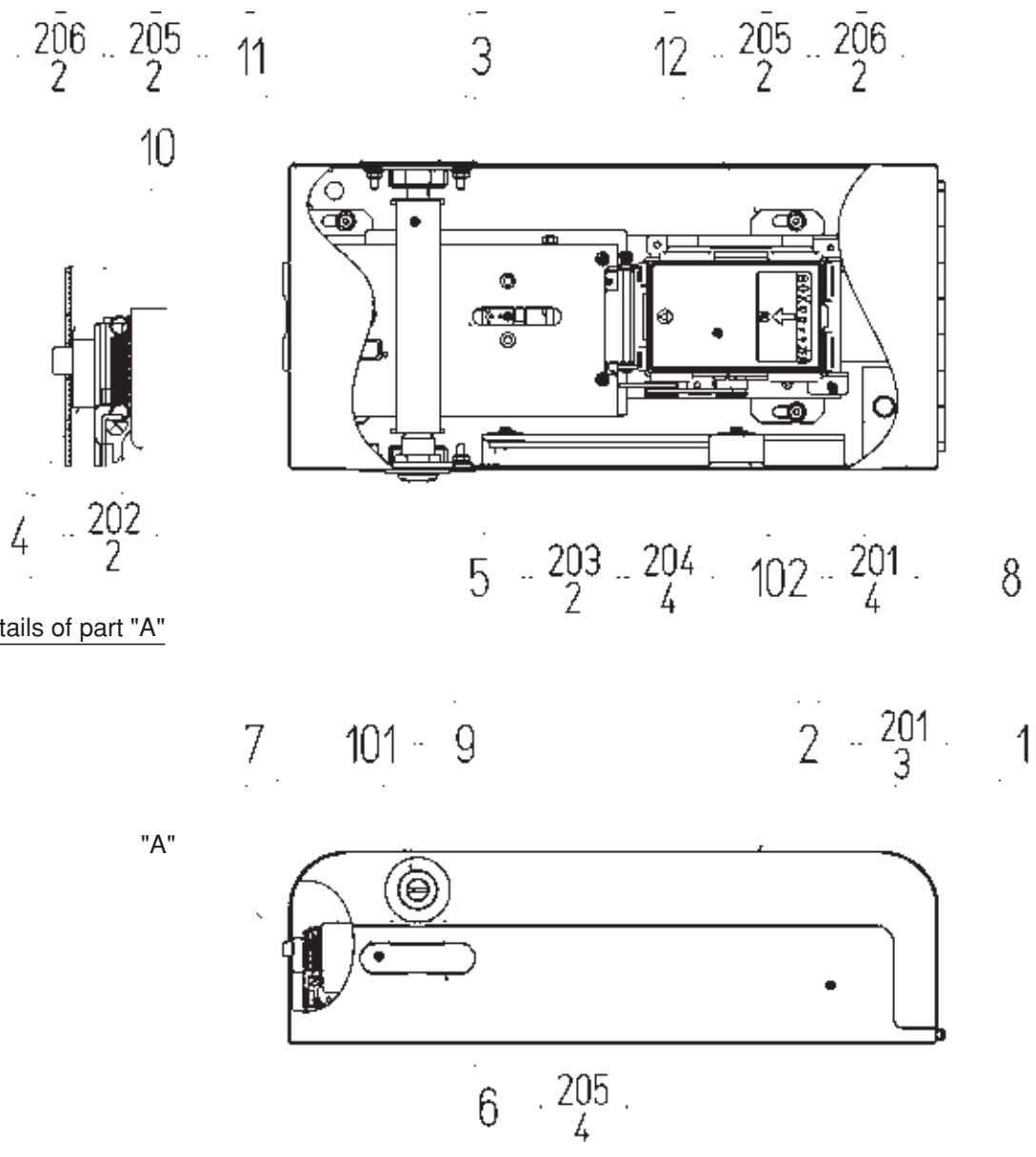

③② CARD UNIT TWIN R (VOF-0460)

(D-2/2)

ITEM NO.	PART NO.	DESCRIPTION	NOTE
1	CKT-0401	CARD R/W BASE TWIN	
2	CKT-0422	CARD R/W COVER TWIN R	
3	CKT-0403	LOCKING TONGUE NARROW	
4	253-5512	CARD GUIDE	
5	CKT-0404	PLATE STAY	
6	CKT-0408	LOCK BRKT S	
7	CKT-1307	STUD PLATE	
8	VOF-0451	CARD R/W BRKT FOR VOF	
9	CKT-0409	SPACER RING	
10	CKT-0406	GATE	
11	CKT-0407	INSULATOR PLATE CKT	
12	VOF-0452	INSULATOR PLATE VOF	
101	220-5575	CAM LOCK MASTER W/O KEY	
102	601-11082	CARD R/W UNIT	
103	280-5277	CORD CLAMP 18	
201	000-P00308-W	M SCR PH W/FS M3 × 8	
202	FAS-000065	M SCR FH BLK M2.6 × 8	
203	065-E00500	E RING 5MM	
204	068-652016	FLT WSHR 6.5-20 × 1.6	
205	050-F00400	FLG NUT M4	
206	000-F00308	M SCR FH M3 × 8	
301	VOF-60050	WH CARD R/W	

③③ METER UNIT (FZR-1460)

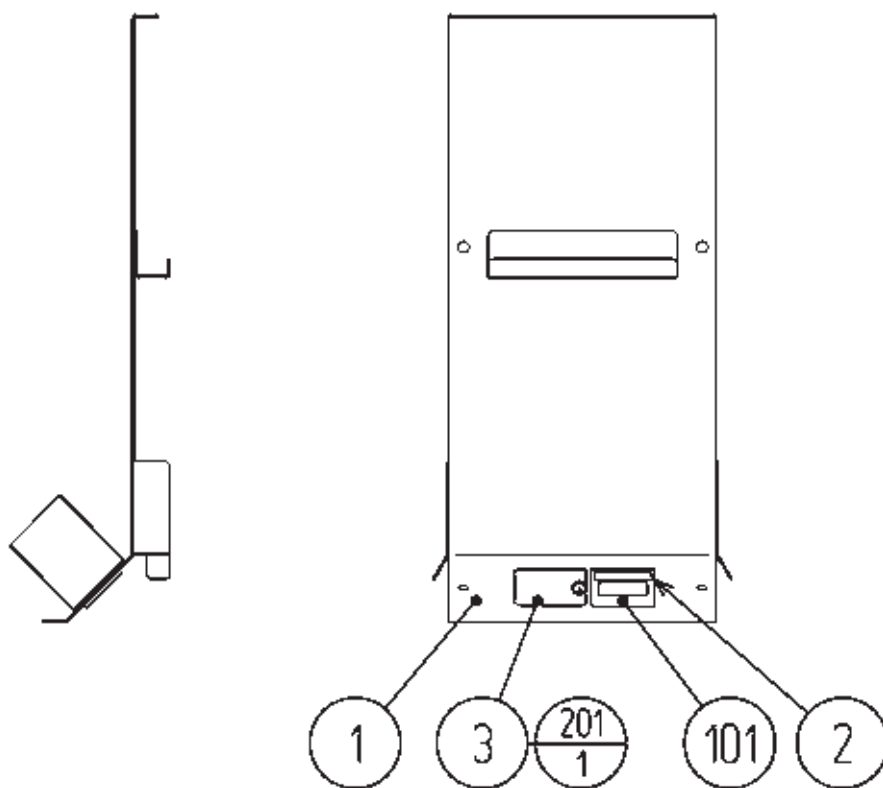

ITEM NO.	PART NO.	DESCRIPTION	NOTE
1	FZR-1461	METER BRKT	
2	421-9168-01	STICKER COIN METER	
3	HOT-1007	LID COIN CNTR NOT USED	<Others> <USA>
101	220-5643-01	MAG CNTR DC5V 6P WH MZ-674-D04	
201	000-P00308-W	M SCR PH W/FS M3 × 8 NOT USED	<Others> <USA>
/	220-5643-02	MAG CNTR DC5V 6P YE MZ-674-D05	<USA>

③④ ASSY FLOOR FRONT (FZR-3800)

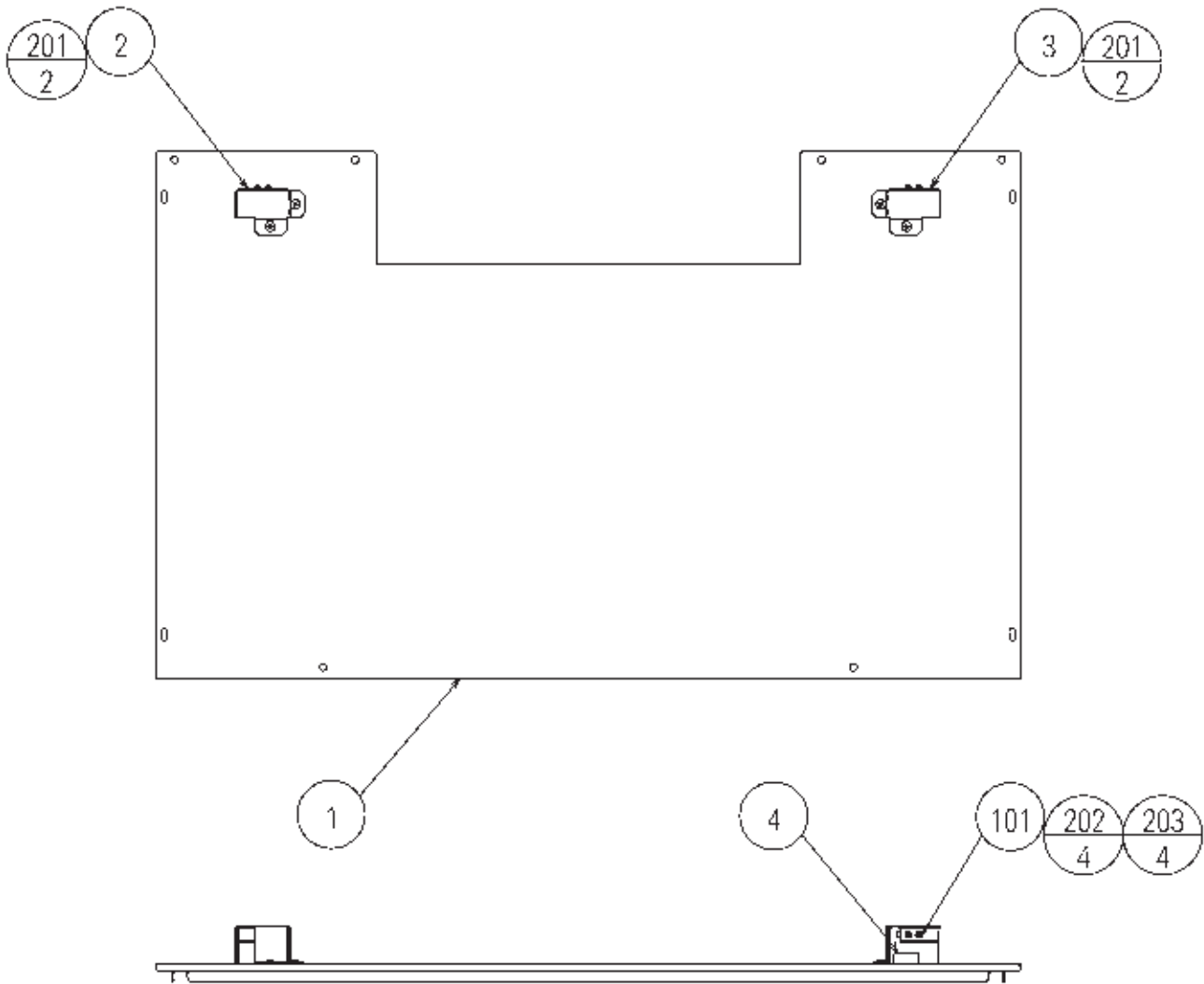

ITEM NO.	PART NO.	DESCRIPTION	NOTE
1	FZR-3801	FLOOR FRONT	
2	FZR-3802	SENSOR BRKT A	
3	FZR-3803	SENSOR BRKT B	
4	FZR-3804	WATER PROOF SPONGE	
101	370-5071-02	BEAM SENSOR(R-9382D-12)	
102	280-5009-01	CORD CLAMP 21	
103	280-5275-SR10	CORD CLAMP SR10	
104	601-6231-D050	EDGING NEW TYPE	
201	000-T00408-0B	M SCR TH BLK M4 × 8	
202	000-P00316-WB	M SCR PH W/FS BLK M3 × 16	
203	050-H00300	HEX NUT M3	
301	FZR-60056	WH SENSOR RX	

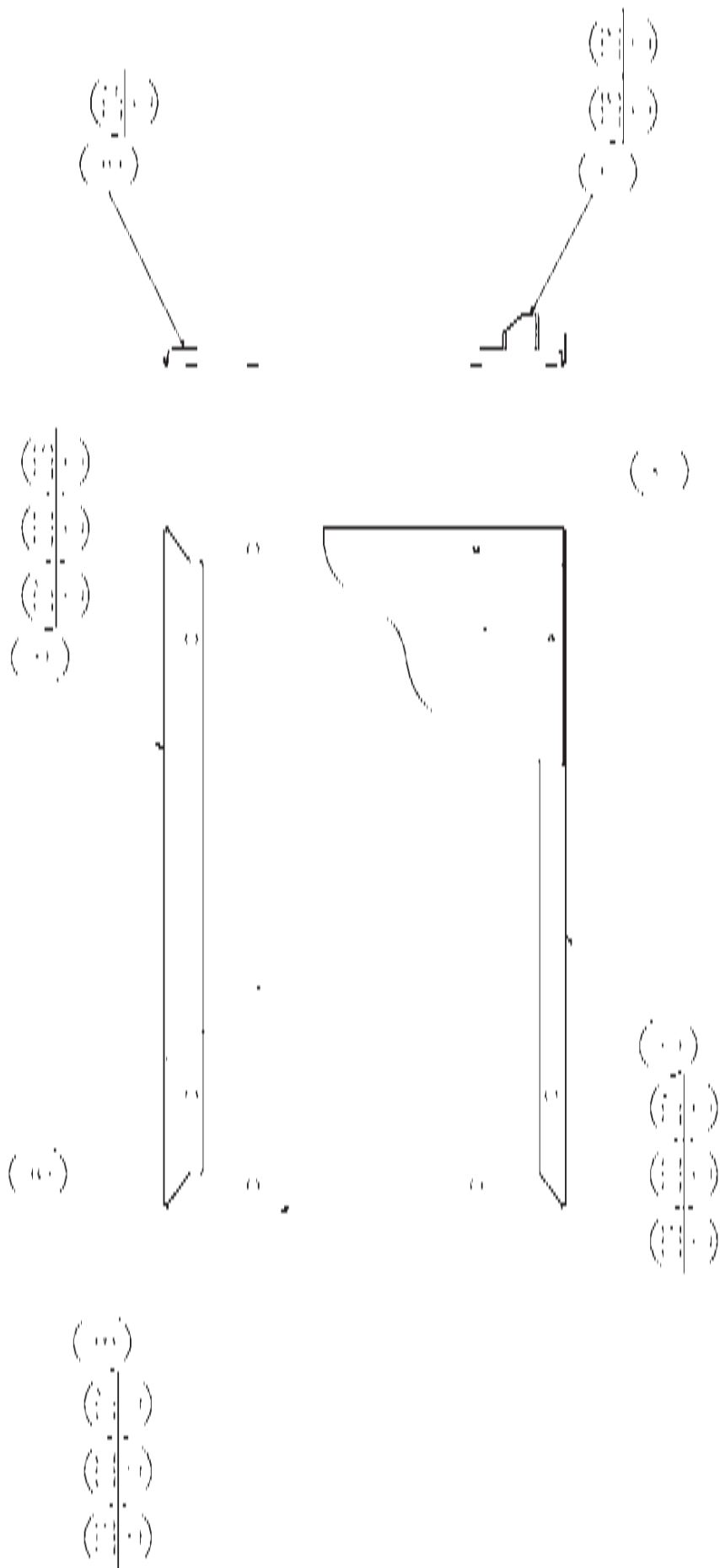

35 ASSY FLOOR R (FZR-3820)

(D-2/2)

ITEM NO.	PART NO.	DESCRIPTION	NOTE
1	FZR-3821	FLOOR RIGHT	
2	FZR-3822	FLOOR SASH A	
3	FZR-3823	FLOOR SASH B	
4	FZR-3824	FLOOR SASH C	
5	FZR-3825	FLOOR MAT	
6	FZR-3826	FLOOR HOOK PLATE	
7	FZR-3827	LOCKING HOOK	
201	031-000516-0C	CRG BLT CRM M5 × 16	
202	050-F00500	FLG NUT M5	
203	068-552016	FLT WSHR 5.5-20 × 1.6	
204	000-P00416-W	M SCR PH W/FS M4 × 16	
205	030-000620-S	HEX BLT W/S M6 × 20	
206	060-F00600	FLT WSHR M6	

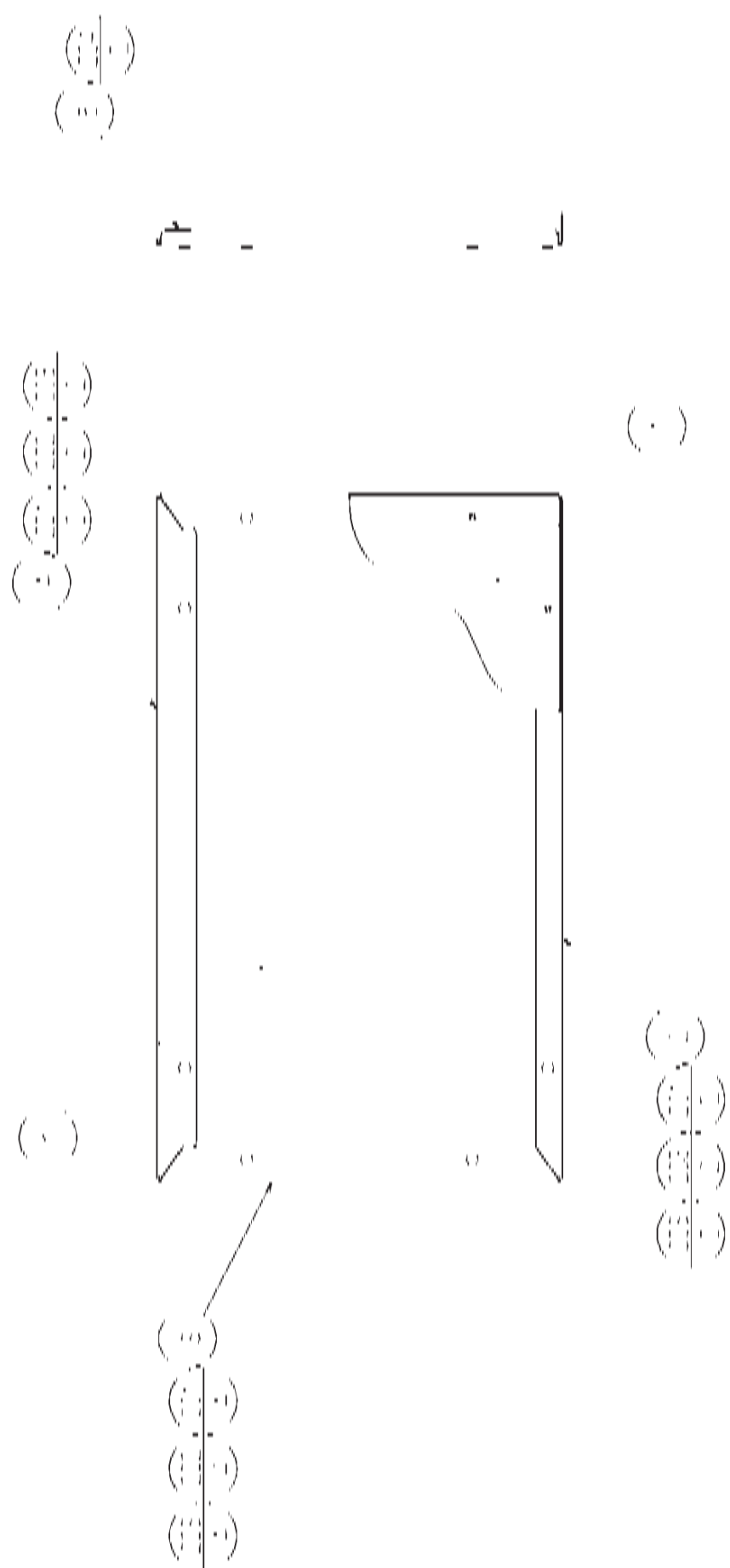

③⑥ ASSY FLOOR L (FZR-3840)

(D-2/2)

ITEM NO.	PART NO.	DESCRIPTION	NOTE
1	FZR-3841	FLOOR LEFT	
2	FZR-3822	FLOOR SASH A	
3	FZR-3823	FLOOR SASH B	
4	FZR-3824	FLOOR SASH C	
5	FZR-3825	FLOOR MAT	
6	FZR-3826	FLOOR HOOK PLATE	
201	031-000516-0C	CRG BLT CRM M5 × 16	
202	050-F00500	FLG NUT M5	
203	068-552016	FLT WSHR 5.5-20 × 1.6	
204	000-P00416-W	M SCR PH W/FS M4 × 16	

③⑦ ASSY FLOOR REAR (FZR-3860)

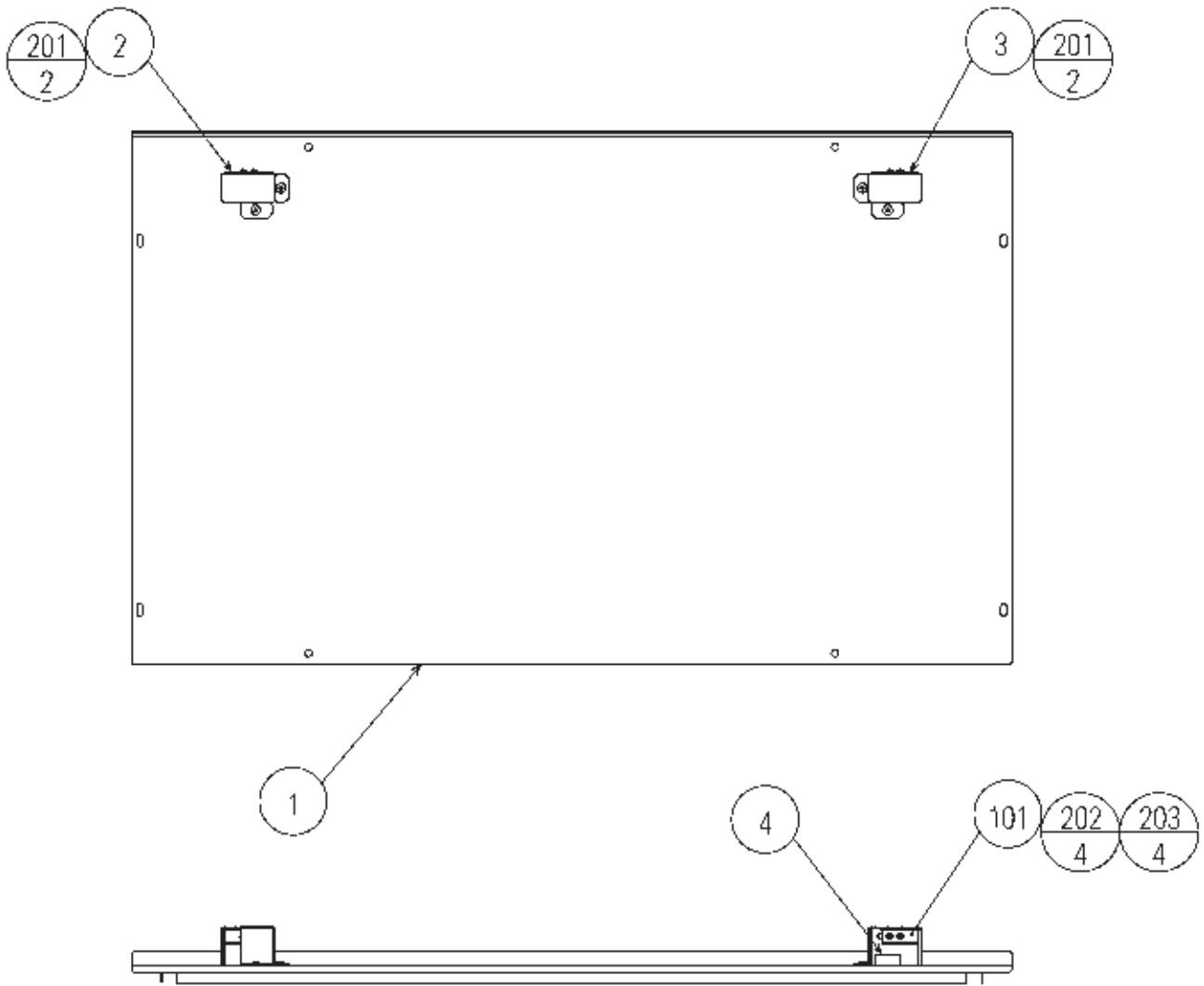

ITEM NO.	PART NO.	DESCRIPTION	NOTE
1	FZR-3861	FLOOR REAR	
2	FZR-3802	SENSOR BRKT A	
3	FZR-3803	SENSOR BRKT B	
4	FZR-3804	WATER PROOF SPONGE	
101	370-5071-01	BEAM SENSOR(L-9382-12)	
102	280-5009-01	CORD CLAMP 21	
103	280-5275-SR10	CORD CLAMP SR10	
201	000-T00408-0B	M SCR TH BLK M4 × 8	
202	000-P00316-WB	M SCR PH W/FS BLK M3 × 16	
203	050-H00300	HEX NUT M3	
301	FZR-60055	WH SENSOR TX	

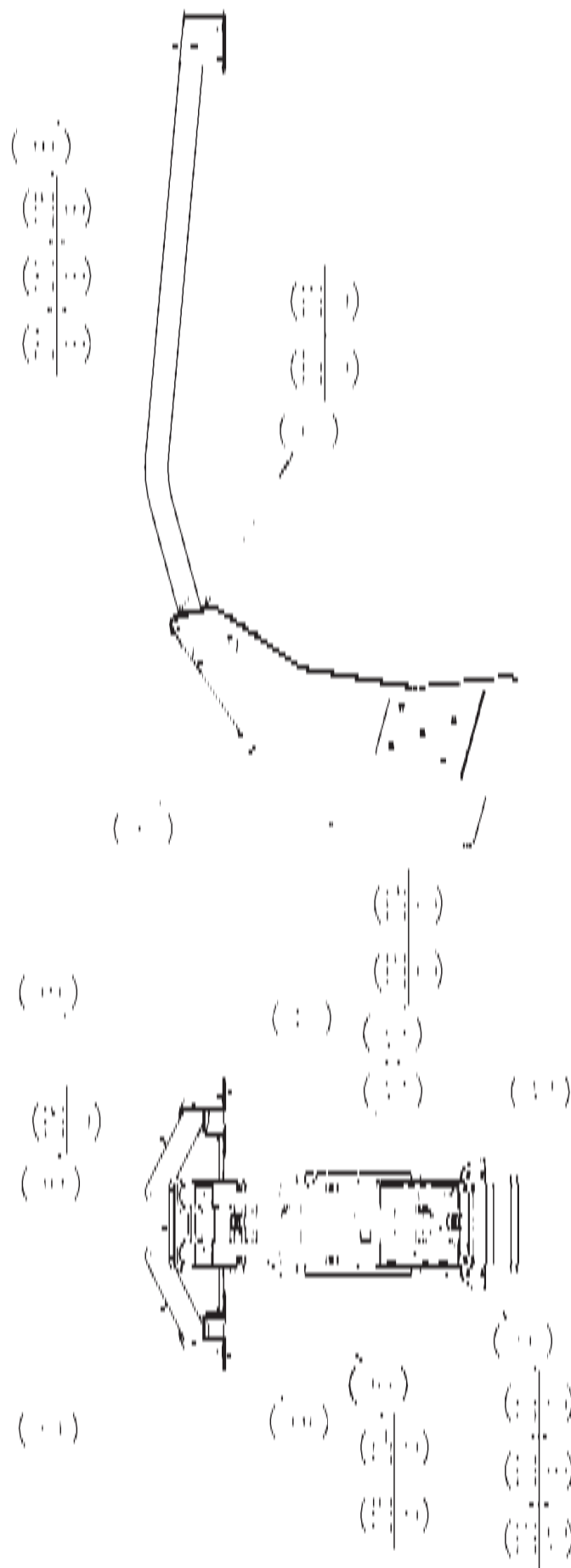

③⑧ ASSY ROOF FRAME (FZR-3900)

(D-2/2)

ITEM NO.	PART NO.	DESCRIPTION	NOTE
1	FZR-3901	LIGHT BOX UPPER	
2	FZR-3902	ROOF FRAME L	
3	FZR-3903	ROOF FRAME R	
4	FZR-3904	PIPE HOLDER REAR A	
5	FZR-3905	PIPE HOLDER REAR B	
6	FZR-3906	TOP JOINT BRKT	
7	FZR-3907	BLIND PLATE	
8	FZR-3908	PIPE HOLDER FRONT A	
9	FZR-3909	PIPE HOLDER FRONT B	
10	253-5457	FL HOLDER	<Others>
		Locally supplied	<USA>
11	FZR-3910	PIPE HOLDER FRONT C	
12	421-7501-17	STICKER FL 20W	<Others>
		Locally supplied	<USA>
101	390-6659-20EX	ASSY FL20W EX W/CONN HIGH S CE	<Others>
		Locally supplied	<USA>
102	280-5275-SR10	CORD CLAMP SR10	
201	030-000880-S	HEX BLT W/S M8 × 80	
202	030-000820-S	HEX BLT W/S M8 × 20	
203	060-F00800	FLT WSHR M8	
204	030-000616-S	HEX BLT W/S M6 × 16	
205	060-F00600-0B	FLT WSHR BLK M6	
206	000-P00408-W	M SCR PH W/FS M4 × 8	
207	000-T00412-0B	M SCR TH BLK M4 × 12	
208	068-441616-0B	FLT WSHR BLK 4.4-16 × 1.6	
209	050-F00400	FLG NUT M4	<Others>
		Locally supplied	<USA>
210	050-H00600-0B	HEX NUT BLK M6	
211	060-S00600-0B	SPR WSHR BLK M6	
301	FZR-60051	WH BILLBOARD02	

③9 ASSY LIGHT BOX LOWER (FZR-3950)

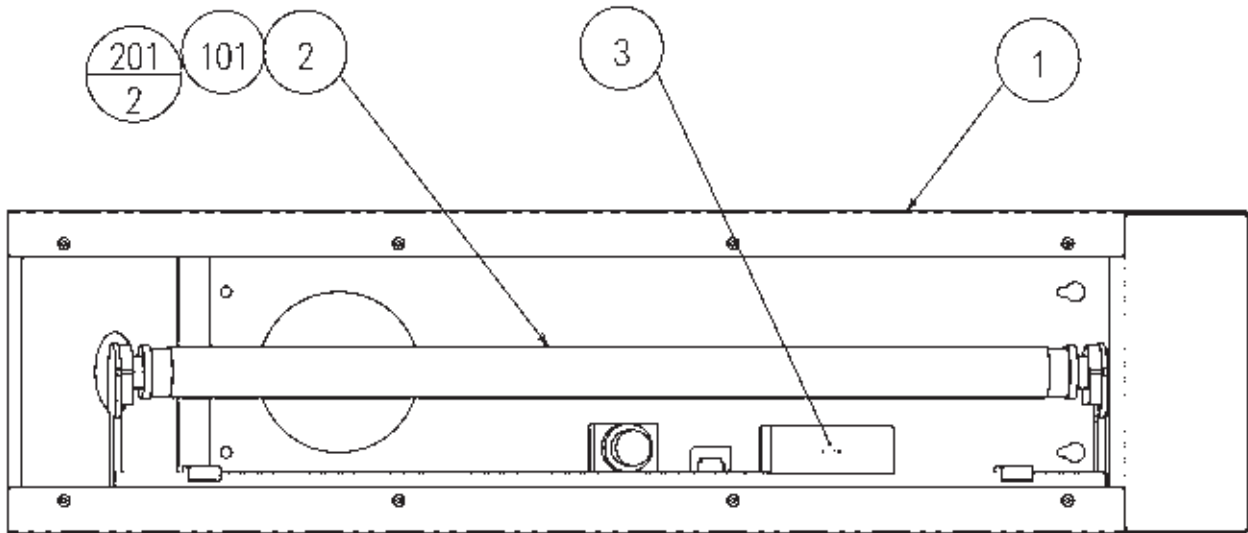

ITEM NO.	PART NO.	DESCRIPTION	NOTE
1	FZR-3951	LIGHT BOX LOWER	
2	253-5457	FL HOLDER Locally supplied	<Others> <USA>
3	421-7501-17	STICKER FL 20W Locally supplied	<Others> <USA>
101	390-6659-20EX	ASSY FL20W EX W/CONN HIGH S CE Locally supplied	<Others> <USA>
102	280-5275-SR10	CORD CLAMP SR10	
201	000-P00430-W	M SCR PH W/FS M4 × 30 Locally supplied	<Others> <USA>
301	FZR-60067	WH BILLBOARD03	

23. WIRE COLOR CODE TABLE

THE WIRE COLOR CODE is as follow:

A	PINK
B	SKY BLUE
C	BROWN
D	PURPLE
E	LIGHT GREEN

Wires other than those of any of the above 5 single colors will be displayed by 2 alphanumeric characters.

1	RED
2	BLUE
3	YELLOW
4	GREEN
5	WHITE
7	ORANGE
8	BLACK
9	GRAY

If the right-hand side numeral of the code is 0, then the wire will be of a single color shown by the left-hand side numeral (see the above).

Note 1: If the right-hand side alphanumeric is not 0, that particular wire has a spiral color code. The left-hand side character shows the base color and the right-hand side one, the spiral color.

<Example> 51 WHITE / RED

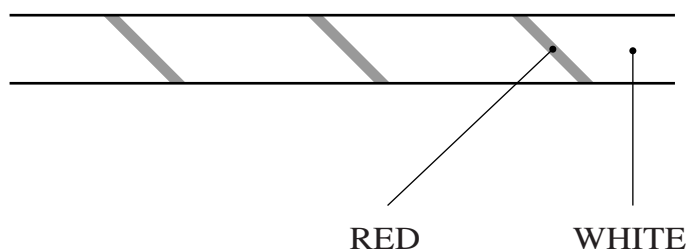

Note 2: The character following the wire color code indicates the size of the wire.

U:	AWG16
K:	AWG18
L:	AWG20
None:	AWG22

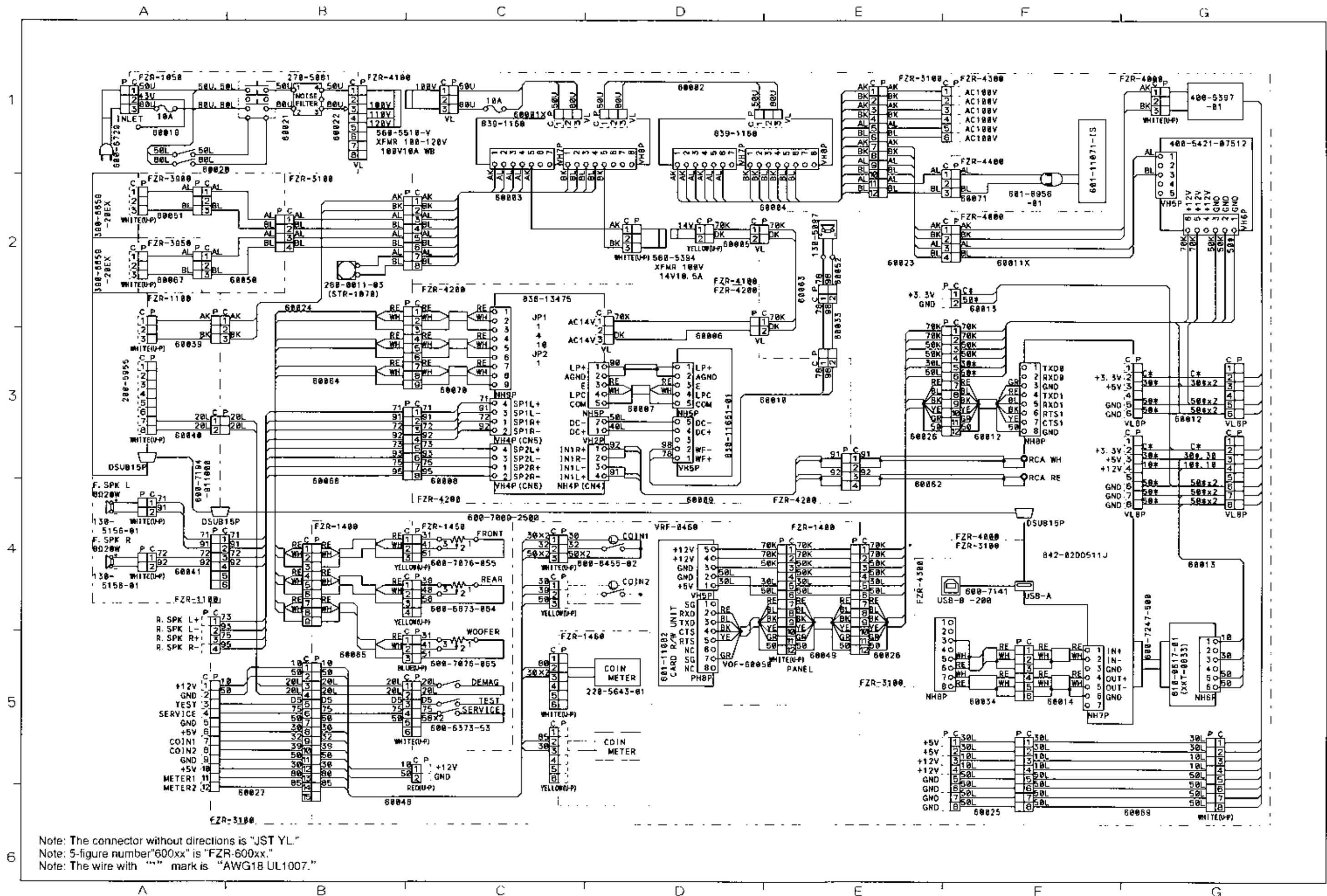

24. WIRING DIAGRAM (D-1/3)

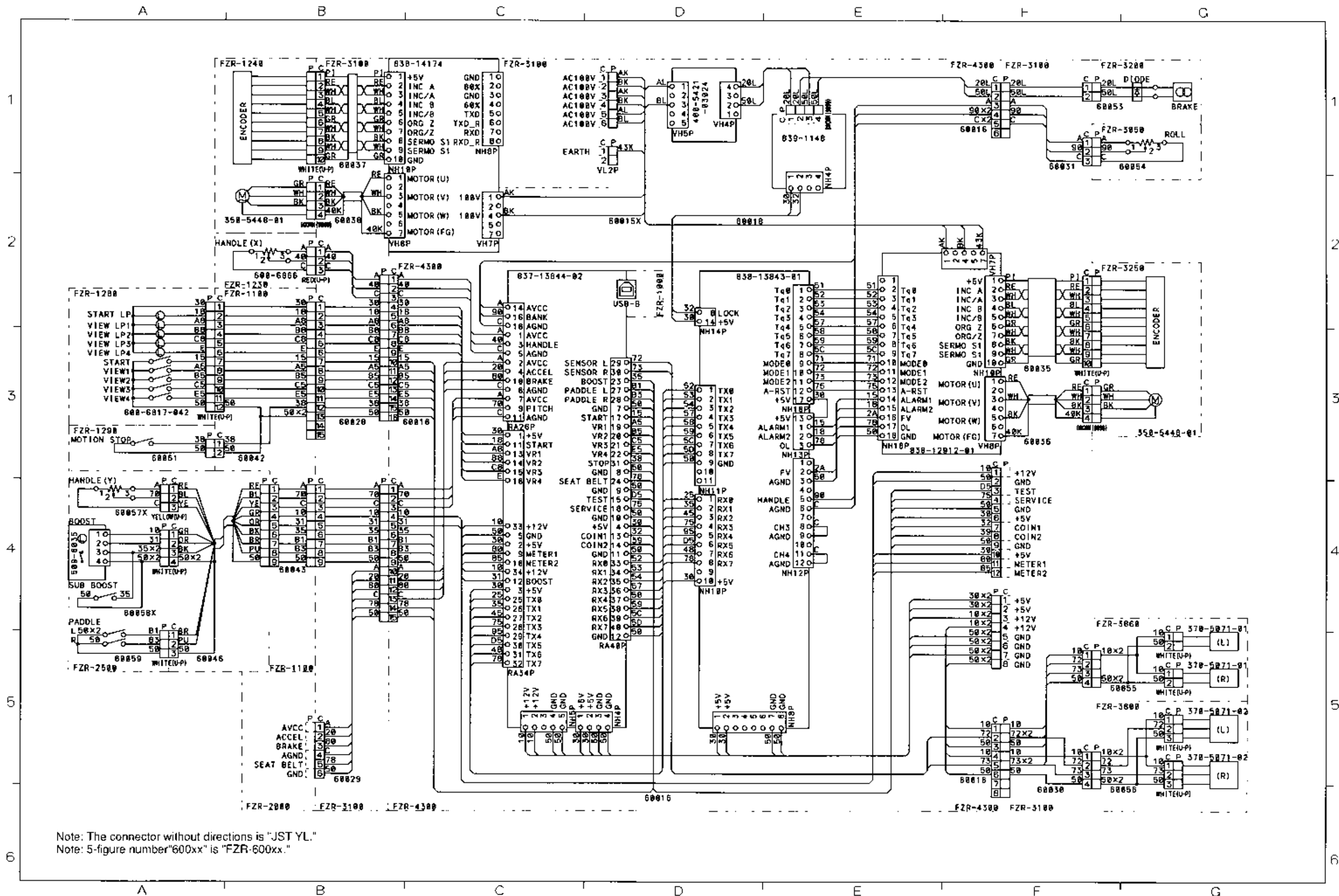

24. WIRING DIAGRAM (D-2/3)

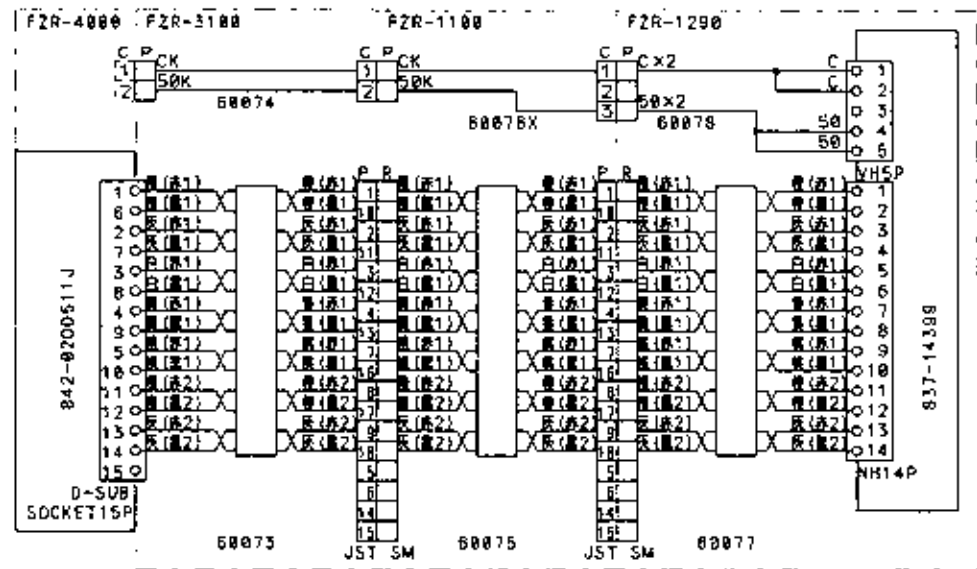
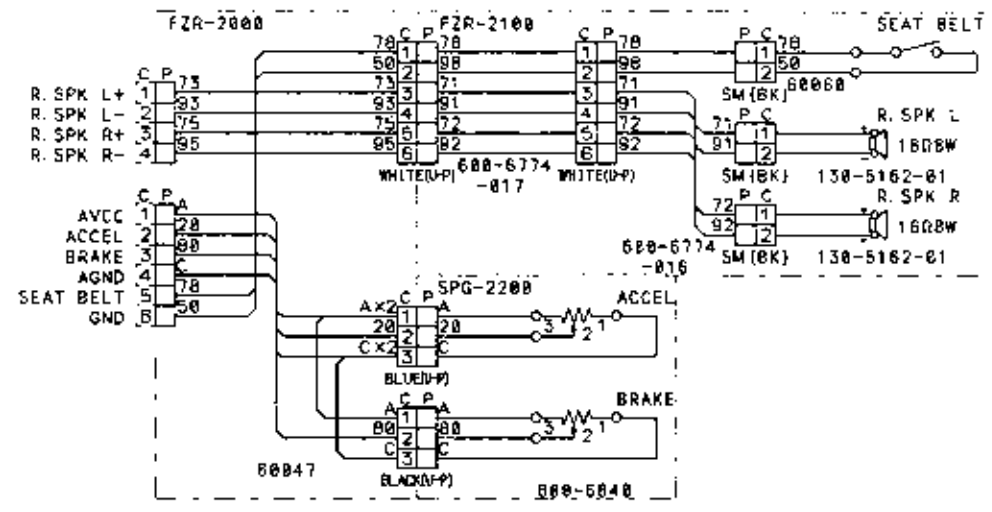

The character in the figure corresponds to the following wire colors respectively.
 橙: ORANGE 赤: RED
 黒: BLACK 灰: GRAY
 白: WHITE 黄: YELLOW
 桃: PINK

The number in the parenthesis shows the number of the point on the wire cover.

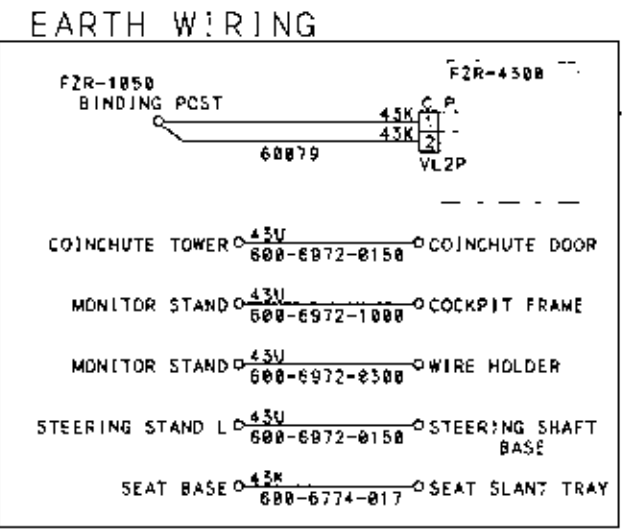
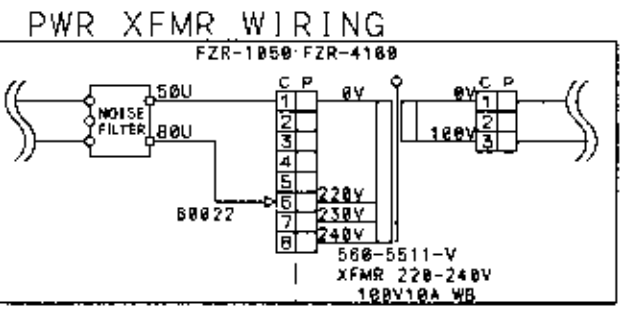

Note: The connector without directions is "JST YL."
 Note: 5-figure number "600xx" is "FZR-600xx."

